



# USER'S MANUAL

## ENERGY STORAGE INVERTER

9KW-12KW

Appliances



PC



TV



Air-conditioning



Fridge



Washing machine

## Table Of Contents

ABOUT THIS MANUAL.....	1
SAFETY INSTRUCTIONS.....	1
PRODUCT INTRODUCTION .....	2
Features.....	2
Basic System Architecture.....	2
Product Overview .....	3
Packing List .....	3
User Environment .....	4
INSTALLATION .....	4
Preparation .....	4
Battery Connection .....	4
PV Connection.....	6
GRID / AC OUTPUT(LOAD) Connection.....	7
Three-Phase Unit Connection.....	8
Single-Phase Unit Connection.....	8
Grounding Connection.....	9
Final Assembly.....	9
Communication and BTS Connection.....	10
Communication Connection.....	10
BTS Connection.....	10
OPERATION.....	11
Operation and Display Panel.....	11
LCD Display Icons.....	12
Commissioning.....	14
LCD Setting.....	16
Display Setting .....	22
Operating State Description.....	23
Fault Reference Code.....	24
Warning Indicator.....	26
SPECIFICATIONS.....	27
Table 1 Line Mode Specifications.....	27
Table 2 Inverter Mode Specifications .....	28
Table 3 Charge Mode Specifications .....	29
Table 4 General Specifications.....	30
TROUBLE SHOOTING .....	31
APPENDIX: APPROXIMATE BACK-UP TIME TABLE.....	32

## ABOUT THIS MANUAL

### Purpose

This manual describes the assembly, installation and troubleshooting of this unit. Please read this manual carefully before installations and operations. Keep this manual for future reference.

### Scope

This manual provides safety and installation guideline as well as information on tool and wiring.

## SAFETY INSTRUCTIONS

- The manual and other documents must be stored in a convenient place and be available at all times. Before using the unit, read all instructions and cautionary markings on the unit the batteries and all appropriate sections of this manual. We assume no liability for any damage caused by failure to observe these instructions.
- **CAUTION** -To reduce rise of injury, charge only deep - cycle lead acid type rechargeable batteries. Other types of batteries may burst, causing personal injury and damage.
- Do not disassemble the unit. Take it to a qualified service center when service or repair is required. Incorrect re-assemble may result in a risk of electric shock or fire.
- To reduce risk of electric shock, disconnect all wirings before attempting any maintenance or cleaning. Turning off the unit will not reduce this risk.
- **CAUTION** - Only qualified personnel can install this device with battery.
- **NEVER** charger a frozen battery.
- For optimum operation of this energy storage inverter, please follow required spec to select appropriate cable size. It's very important to correctly operate this energy storage inverter.
- Be very cautious when working with metal tools on or around batteries. A potential risk exists to drop a tool to spark or short circuit batteries or other electrical parts and could cause an explosion.
- Please strictly follow installation procedure when you want to disconnect AC or DC terminals, Please refer to INSTALLATION section of this manual for the battery supply.
- Fuse 2 pieces of 200A,58VDC for 9KW/10KW,3pieces of 300A,58VDC for 12KW, are provided as over-current protection for the battery supply.
- **GROUNDION INSTRUCTIONS**-This energy storage inverter should be connected to a permanent grounded Wiring system. Be sure to comply with local requirements and regulation to install this inverter.
- **NEVER** cause AC output and DC input short circuited.Do NOT connect to the mains when DC input short circuits.
- **Warning!!**Only qualified service persons are able to service this device. If errors still persist after following troubleshooting table, please send this energy storage inverter back to local dealer or service center for maintenance.
- **Caution** - We will not be responsible for any breakdown or damage caused by transportation, movement or negligence after purchase.
- **Caution** - We are not responsible for failures caused by the use of the power supply conditions or the site environment not specified in the electrical specifications of the inverter.

## PRODUCT INTRODUCTION

This is a multi-function Energy Storage Inverter, combining functions of inverter, On-Grid, MPPT solar charger and battery charger to offer uninterruptible power support. It's comprehensive LCD display offers user-configurable and easy-accessible button operation such as battery charging current, AC/solar charger priority, and acceptable input voltage based on different applications.

## Features

- Pure sine wave inverter.
- Built-in MPPT solar charge controller.
- On-grid Inverter with Energy Storage.
- Selectable input voltage range for home appliances and personal computers LCD setting.
- Selectable battery charging current based on applications via LCD setting.
- Selectable Multiple application modes: Load priority mode, Math load mode, Sell mode, Backup UPS mode and Off grid priority mode.
- Auto restart while AC is recovering.
- Smart battery charge design for optimized battery performance.
- Multiple communication for RS-485、CAN BUS and USB.
- Overload and short circuit protection.

## Basic System Architecture

This energy storage inverter can provide Power to connected loads by utilizing PV power, grid power and battery power.

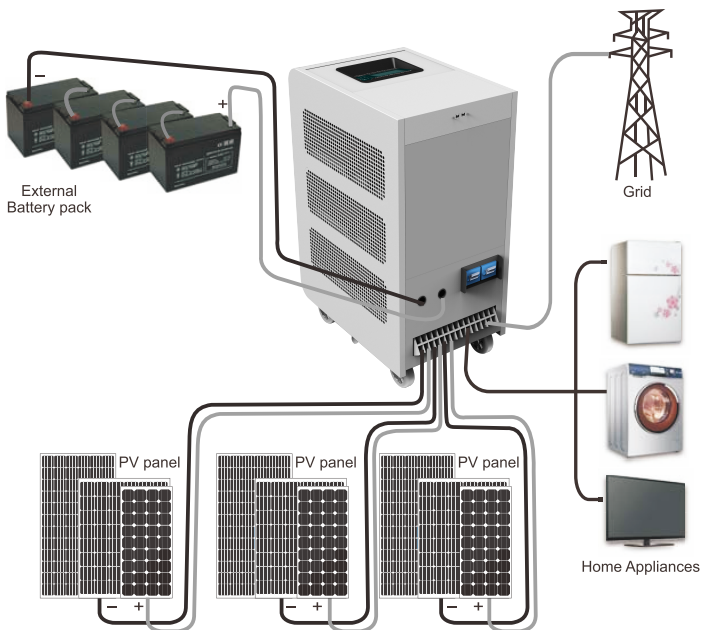

## Product Overview

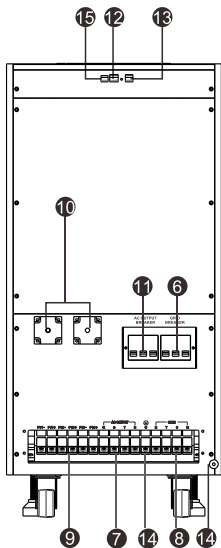
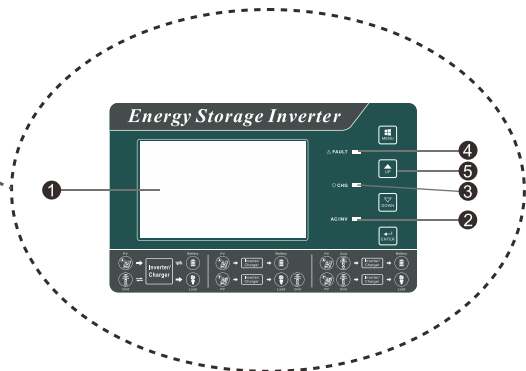
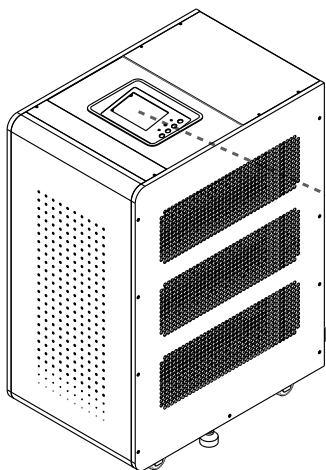

1. LCD display
2. Status indicator
3. Charging indicator
4. Fault indicator
5. Function buttons
6. Grid breaker
7. AC Output
8. Grid
9. PV input
10. Battery input
11. AC output breaker
12. CAN & RS485 communication port
13. BTS
14. Grounding
15. USB communication port

## Packing List

Before installation, please inspect the unit, Be sure that nothing inside the package is damaged. You should have received the following items inside of package:

- |  |                |
|--|----------------|
| The unit x1                              | User manual x1 |
| Software CD x1                           | BTS cable x1   |
| Communication cable x1                   |                |
| AC cable x2 (only for single-phase unit) |                |

## User Environment

- Put the inverter on level floor and lock brake wheel.
- On both side of the inverter more than 50cm from walls or other obstructions, to facilitate heat dissipation.
- Do not put the inverter near flammable construction materials.
- Avoid direct sunlight, rain, or use of the inverter in damp conditions.
- The inverter cannot be used in Corrosive materials, salt and combustible gas.

## INSTALLATION

### Preparation

Before connecting all wirings, please take off bottom cover by removing six screws as shown below.

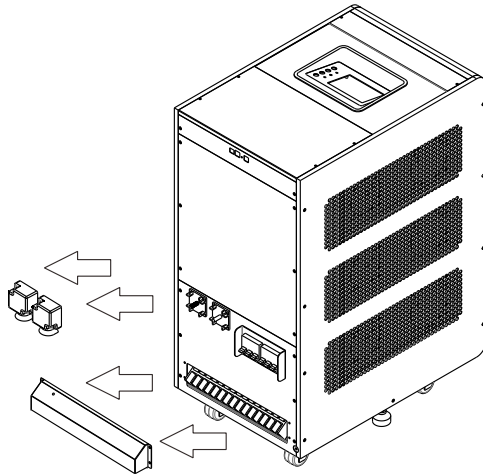

### Battery Connection

**CAUTION:** For safety operation and regulation compliance, it's requested to install a separate DC over-current protector or disconnect device between battery and inverter. It may not be requested to have a disconnect device in some applications, however, it's still requested to have over-current protection installed. Please refer to typical amperage in below table as required fuse or breaker size.

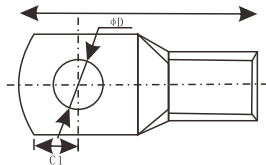

**WARNING!** All wiring must be performed by a qualified personnel.

**WARNING!** It's very important for system safety and efficient operation to use appropriate cable for battery connection. To reduce risk of injury, please use the proper recommended cable and terminal size, As shown in the following table.

**Notice:** Please only use sealed lead acid battery and Lithium battery.

**Notice:** Please check maximum charging voltage and current when first using this inverter.

**Notice:** Please use 60VDC/300A circuit breaker.

Please follow below steps to implement battery connection:

- Step 1: Check the nominal voltage of batteries. The nominal input voltage for inverter is 48VDC.
- Step 2: User battery cable remove insulation sleeve 10mm to crimping terminal and heat shrinkable sleeve(25mm).
- Step 3: Connect battery positive cable to battery positive of unit silk-screen, connect battery negative cable to battery negative of unit silk-screen. Using M8 nut tightened with torque 2~3Nm.

**Notice:** Make sure polarity of the battery and the energy storage inverter is correctly connected.

**Notice:** Make sure ring terminals are tightly screwed to the battery terminals.

**WARNING!** Wrong connections will damage the unit permanently.

**Recommended battery cable and terminal size:**

Mode	Typical Amperage	Battery Capacity	Wire Size	Ring Terminal		Torque Value	
				Cable (mm <sup>2</sup> )	Dimensions		
					D(mm)		L(mm)
9KW/ 10KW	180A	400AH	2*3AWG	54	8.4	35	2~3Nm
			3*4AWG	63			
12KW	240A	600AH	2*2AWG	67	8.4	39	2~3Nm
			3*3AWG	80			

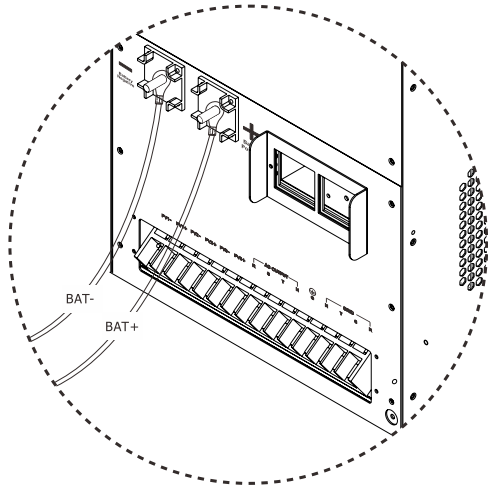
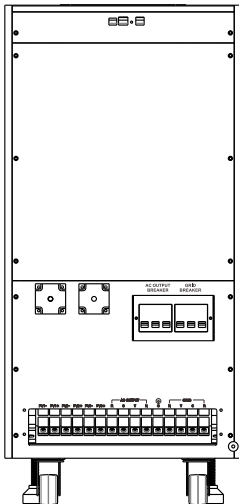

**WARNING: Shock Hazard**

Installation must be performed with care due to high battery voltage in series.



**CAUTION!!** Do not place anything between the flat part of the inverter terminal and the ring terminal. Otherwise, overheating may occur.

**CAUTION!!** Do not apply anti-oxidant substance on the terminals before terminals are connected tightly.

**CAUTION!!** Before making the final DC connection or closing DC breaker/disconnector, be sure positive(+) must be connected to positive(+) and negative(-) must be connected to negative(-).

**PV Connection**

**Notice:** The unit is built-in three independence solar charge controllers, which input interface corresponds to PV1, PV2 and PV3 ports respectively. You can only connect PV1, PV2, PV3 alone, or connect two groups, or three groups are connected.

**CAUTION:** Before connecting to PV modules, please install separately a DC circuit breaker between the unit and PV modules.

**WARNING!** All wiring must be performed by a qualified personnel.

**WARNING!** It's Very important for system safety and efficient operation to use appropriate cable for PV module connection. To reduce rise of injury, please use the proper recommended cable size as below.

6AWG(13.3mm<sup>2</sup>) is recommended for PV connection.

**PV Module Selection:**

When selecting proper PV modules, please be sure to consider below parameters:

1. Open circuit Voltage(Voc) of PV modules not exceeds max. PV array open circuit voltage of inverter.
2. Open circuit Voltage(Voc) of PV modules should be higher than min. Battery voltage.

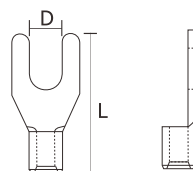
**Ring terminal:**

Solar Charger Mode	
INVERTER MODEL	9KW/10KW/12KW
Max. PV Array Open Circuit Voltage	145Vdc
PV Array MPPT Voltage Range	64Vdc~130Vdc
Min. Battery Voltage for PV charge	34Vdc



**Please follow below steps to implement PV connection:**

Step 1: Remove insulation sleeve 8mm and insert conductor into cable ring terminal.

Step 2: Check correct connection between the solar panel and the PV input terminal. PV1 terminal is connected with the first group of panel, PV2 terminal is connected with the second group of panel, and PV3 terminal is connected with the third group of panel. PV1 terminal is connected with the first group of panel, PV2 terminal is connected with the second group of panel, and PV3 terminal is connected with the third group of panel. PV1 +, PV2 + and PV3 + are respectively connected to the positive pole of the solar panel, and the negative pole of the solar panel are respectively connected with PV1-, PV2- and PV3-.

**Notice:** PV1, PV2 and PV3 cannot be connected, they are independent of each other.

Step 3: Make sure the wires are right and securely connected.

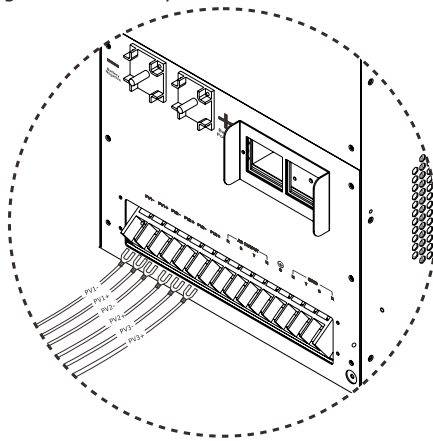
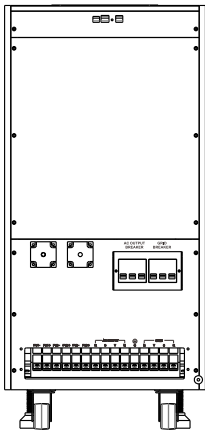

**GRID / AC OUTPUT(LOAD) Connection**

**Preparation**

**CAUTION!!** Before connection to Grid, please install a separate AC breaker between inverter and Grid. This will ensure the inverter can be securely disconnected during maintenance and fully protected from over current of Grid. The recommended spec of AC breaker is 50A/400V for the three-phase unit, 100A/400V for the single-phase unit.

**CAUTION!!** There are two terminal blocks with "AC OUTPUT" and "GRID" markings. Please do NOT-misconnect load and grid connectors.

**WARNING!** It's very important for system safety and efficient operation to use appropriate cable for AC connection. To reduce risk of injury, please use the proper recommended cable terminal size as below.

	Mode 9KW/10KW/ 12KW	Wire Size	Ring Terminal			Torque Value
			Cable (mm <sup>2</sup> )	Dimensions		
				D(mm)	L(mm)	
three-phase unit	AC OUTPUT/GIRD	10~8 AWG	5.3~8.4	6.3	25	2~2.5Nm
		8-6 AWG	8.4~13.3	6.3	29	2~2.5Nm
single-phase unit	AC OUTPUT/GRID	6AWG/2*8AWG	13.3~17	6.3	29	2~2.5Nm

**Please follow below steps to implement AC connection:**

**Three-Phase Unit Connection**

**Notice:** Single-phase and three-phase unit wiring is not the same, cannot be mistaken, otherwise it will cause a short circuit.

**Notice:** Before connecting the grid to this unit, disconnect the PV and battery from the unit, And disconnect the main switch on the grid side.

**Notice:** Before connecting the load to this unit, disconnect the PV, battery, and grid from the unit.

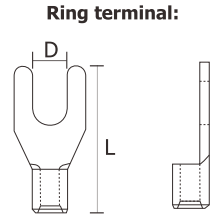

Step 1: Remove insulation sleeve 8mm for conductors and crimping terminal and heat shrinkable sleeve(25mm).

Step 2: Connect the load phases R, S, T and N to the terminals marked "AC OUTPUT" -R, -S, -T, -N on this unit. Tighten the terminal screws.

Step 3: Connect the R-phase, S-phase, T-phase and N-phase of the three-phase grid to the terminals marked "GRID" -R, -S, -T, -N on this unit. Tighten the terminal screws.

Step 4: Make sure the wires are securely connected.

**Notice:** be sure to connect the N line to this unit.

**Single-Phase Unit Connection**

Step 1: Remove insulation sleeve 8 mm for conductors and crimping terminal and heat shrinkable sleeve(25mm).

Step 2: Connect the terminal marked "AC OUTPUT" -R, -S, -T of this unit with an AC wire. Wire as shown below.

Step 3: Connect the terminal marked "GRID" -R, -S, -T of this unit with an AC wire. Wire as shown below.

Step 4: Connect the L phase of the load to the terminal marked "AC OUTPUT" -R, -S, -T in this unit. You can connect one terminal, two terminals or three terminals at will. And connect the N phase of the load to the terminal marked "AC OUTPUT" -N on this unit. Tighten the terminal screws.

Step 5: Connect the L phase of the grid to the terminal marked "GRID" -R, -S, -T in this unit. You can connect one terminal, two terminals or three terminals at all. And connect the N phase of the grid to the terminal marked "GRID" -N on this unit. Tighten the terminal screws.

**CAUTION: Important**

Be sure to connect AC with correct polarity. For the three-phase unit, if the R-phase, S-phase and T-phase of the grid are connected in reverse, this unit will cause a connection failure. For the single-phase unit, if the L-phase and N-phase of the grid are connected in reverse, this unit will cause a short circuit.

**CAUTION:** Appliances such as air conditioner are required at least 2~3 minutes to restart because it's required to have enough time to balance refrigerant gas inside of circuits. If a power shortage occurs and recovers in a short time, it will cause damage to your connected appliances. To prevent this kind of damage, please check manufacturer of air conditioner if it's equipped with time-delay function before installation. Otherwise, the unit will trig overload fault and cut off output to protect your appliance but sometime it still causes internal damage to the air conditioner.

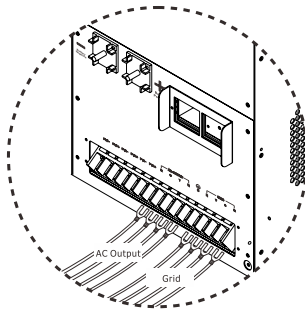
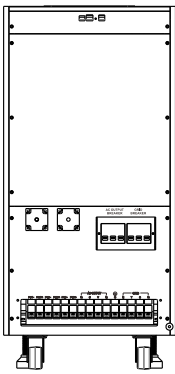

Three-Phase Unit

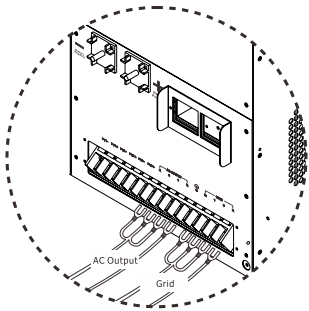

Single-Phase Unit

### Connecting To The Ground

For safety reasons, the unit must be connected to the earth. The terminal marked "G" on this unit and the hole marked ⊕ on the box of this unit are connected to earth.

Wire Size	Ring Terminal		Torque Value
	Cable (mm <sup>2</sup> )	Dimensions	
8AWG	10	D(mm) L(mm)	2~2.5Nm

Ring terminal:

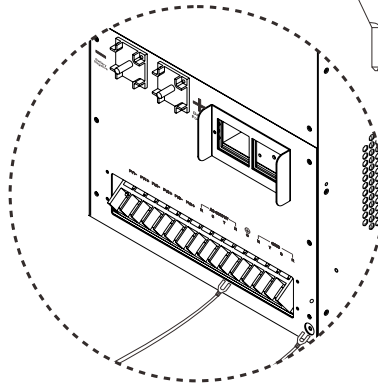
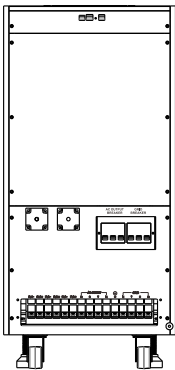
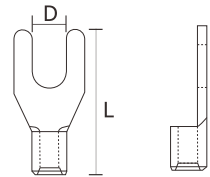

### Final Assembly

After connecting all wirings, please put bottom cover back by screwing six screws as shown below.

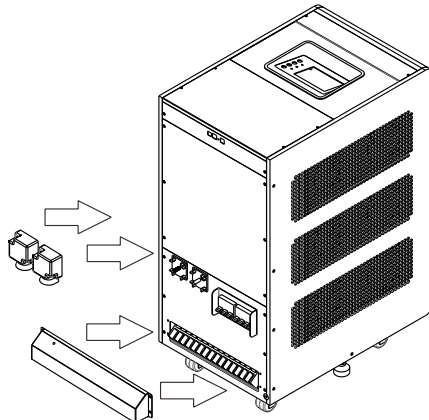

## Communication And BTS Connection

### Communication connection

Please use supplied communication cable to connect to inverter and PC. Insert bundled CD into a computer and follow on-screen instruction to install the monitoring software. For the detailed software operation, please check user manual of software inside of CD. You should use communication cable as follows.

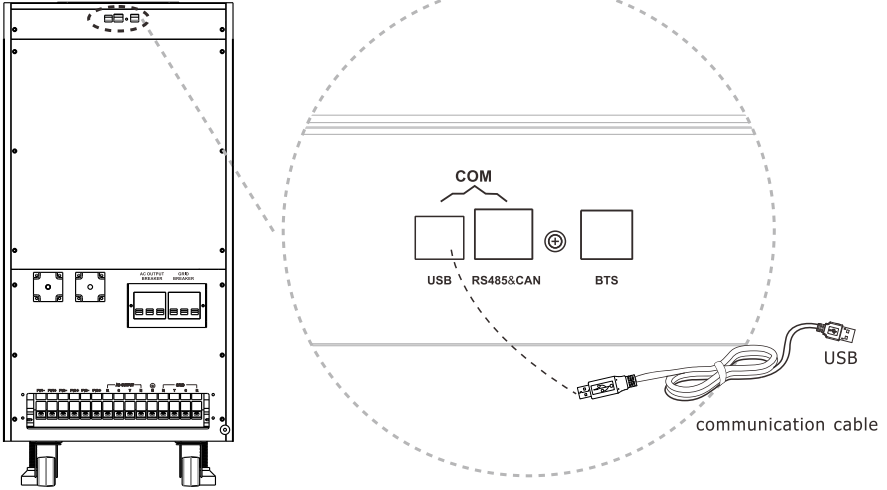

### BTS connection

An optional battery Remote Temperature Sensor(BTS) is recommended for accurate battery recharging. The controller will not perform temperature compensation for charging parameters if the BTS is not used. You should use the RJ11 cables to connect Negative Temperature Coefficient(NTC), as follows:

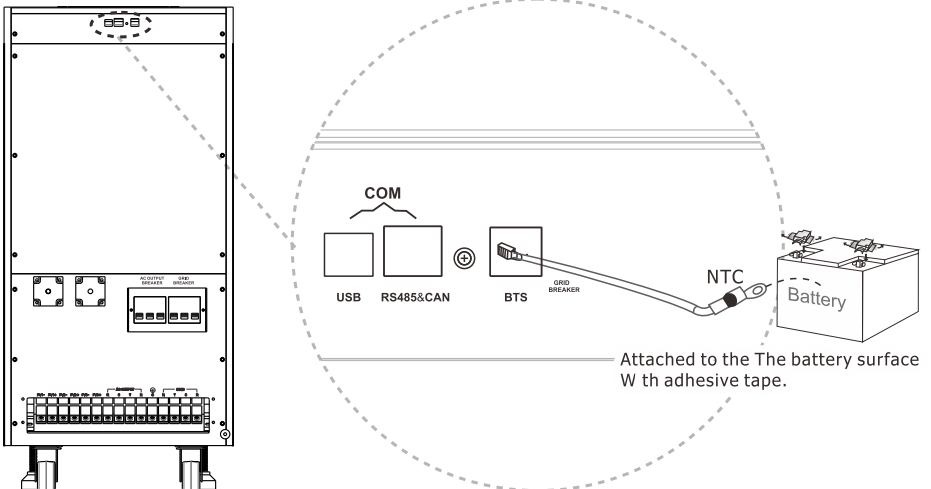

## OPERATION AND DISPLAY PANEL

The operation and display panel, shown in below chart, is on the front panel of the inverter. It includes three indicators, four function keys and a LCD display, indicating the operating status and input/output power information.

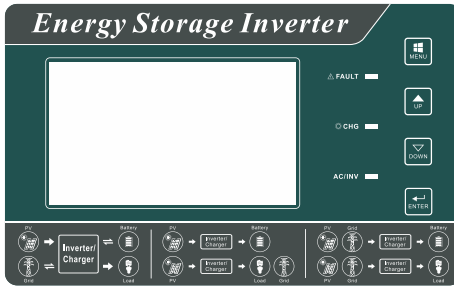

### LED Indicator

LED Indicator		Messages	
AC/ INV	Green	Solid On	Output is powered by Grid in Line mode.
		Flashing	Output is powered by battery or PV in battery mode
CHG	Yellow	Flashing	Battery is charging /or discharging.
FAULT	Red	Solid On	Fault occurs in the inverter.
		Flashing	Warning condition occurs in the inverter.

### Function Keys

Function key	Description.
MENU	Enter or exit setting mode go to previous selection.
UP	Increase the setting data.
DOWN	Decrease the setting data.
ENTER	Confirm the selection in setting mode or go to next selection.

# LCD Display Icons

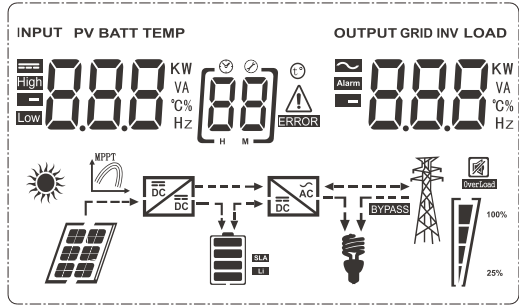

Icon	Function description	
<b>Input Source Information and Output Information</b>		
	Indicates the AC information	
	Indicates the DC information	
	Indicate input voltage, input frequency, PV voltage, battery voltage and charger current. Indicate output voltage, output frequency, load in VA, load in Watt and discharging current.	
<b>Configuration Program and Fault Information</b>		
	Indicates the setting programs.	
	Indicates the warning and fault codes. Warning: flashing with warning code. Fault: lighting with fault code.	
<b>Battery Information</b>		
	Indicates battery level by 0-24%, 25-49%, 50-74% and 75-100% in battery mode and charging status in line mode.	
In AC mode, it will present battery charging status.		
Status	Battery voltage	LCD Display
Constant Current mode / Constant Voltage mode	<2V/cell	4 bars will flash in turns.
	2 ~ 2.083V/cell	Bottom bar will be on and the other three bars will flash in turns.
	2.083 ~ 2.167V/cell	Bottom two bars will be on and the other two bars will flash in turns.
	> 2.167 V/cell	Bottom three bars will be on and the top bar will flash.
Floating mode. Batteries are fully charged.		4 bars will be on.

In battery mode, it will present battery capacity.				
Load Percentage	Battery Voltage		LCD Display	
Load >50%	< 1.717V/cell			
	1.717V/cell ~ 1.8V/cell			
	1.8 ~ 1.883V/cell			
	> 1.883 V/cell			
50%> Load > 20%	< 1.817V/cell			
	1.817V/cell ~ 1.9V/cell			
	1.9 ~ 1.983V/cell			
	> 1.983			
Load < 20%	< 1.867V/cell			
	1.867V/cell ~ 1.95V/cell			
	1.95 ~ 2.033V/cell			
	> 2.033			
Load Information				
	Indicates overload.			
	Indicates the load level by 0-25%, 25-50%, 50-75% and 75-100%.			
	0%~25%	25%~50%	50%~75%	75%~100%
Mode Operation Information				
	Indicates unit connects to the mains.			
	Indicates unit connects to the PV panel.			
	Indicates load is supplied by utility power.			
	Indicates the solar charger circuit is working.			
	Indicates the DC/AC inverter circuit is working.			
Mute Operation				
	Indicates unit alarm is disabled.			

## Commissioning

Step 1: Make sure that the following requirements are met before running this unit.

- Make sure that the battery and the solar panel are connected correctly to the unit. (See page 4 to 7)
- Make sure that the GRID and the load are connected correctly to the unit. (See page 7 to 9)
- Make sure that the unit is well connected to the ground. (See page 9)

Step 2: Turn on the AC output side circuit breaker, the battery side circuit breaker and the PV side circuit breaker in sequence.

If you unit is three-phase, it should be display as follow:

LCD display in R-phase unit	LCD display in S-phase unit	LCD display in T-phase unit

If you unit is single-phase, it should be display as follow:

LCD display in modules-1 of unit	LCD display in modules-2 of unit	LCD display in modules-3 of unit

**Notice:** In single-phase unit, the modules displays maybe S1, H2, S3 or S1, S2, H3, these condition are normal.

Step 3: Turn on the GRID side breaker. If grid is detected (the three-phase should matched with unit setting), they will work normally. Otherwise the AC icon  will flash and it will not work in line mode.

If you unit is three-phase, it should be display as follow:

LCD display in R-phase unit	LCD display in S-phase unit	LCD display in T-phase unit



If your unit is single-phase, it should be displayed as follows:

LCD display in modules-1 of unit	LCD display in modules-2 of unit	LCD display in modules-3 of unit

**Notice:** in single-phase unit, the modules displays maybe S1, H2, S3 or S1, S2, H3, these condition are normal.

Step 4: If there is no more fault alarm, the system is completely installed.

Step 5: Please switch on all breakers of Line wires in load side. This system will start to provide power to the load.

**Notice:** To avoid overload occurring, before turning on breakers in load side, it's better to have whole system in operation first.







**Notice:** Transfer time for this operation exists. Power interruption may happen to critical devices, which cannot bear transfer time.







## LCD Setting

After pressing and holding MENU button for 2 seconds, the unit will enter setting mode. Press "UP" or "DOWN" button to select setting programs. And then, press "ENTER" or "MUNE" button to confirm the selection and exit.

### Setting Programs:

Program	Selectable option	Description
	[51] INV	Select the setting of inverter.
	[52] CHA	Select the setting of solar charger.
	[53] S45	Select the setting of the system.
Power use mode	Load priority mode [01] PL	PL: Solar energy provides power to the loads as first priority. If solar energy is not sufficient to power all connected loads, battery energy will supply power the loads at the same time. If the solar energy is larger than the load and the battery voltage is higher than the max voltage, the solar energy will sell to the grid.
	Match load mode [02] FL	FL: the energy will never sell to the grid and the solar energy will fully supply to the load.
	Sell mode [03] FS	FS: the solar energy will Sell to the grid ignore the load.
	Backup UPS mode [04] UPS	UPS: the converter will charger the battery to full voltage Combine with the Solar Charge Controller.
	Off grid priority mode [05] PO	PO: the inverter will turn to off grid state when the solar energy is enough.
Maximum charging current(DC)	[02] 120 <sup>A</sup>	To configure total charging current for solar and grid (Max. charging current=grid charging current+solar charging current the actual parameters in Table 3). (in page 31)
Maximum Grid charging current(DC)	[03] 60 <sup>A</sup>	The actual parameters in Table 3.(in page 31)
Maximum discharging current (DC)	[04] 130 <sup>A</sup>	Maximum Discharging current: To configure Max Discharging current when the inverter is on Grid-tie mode.the actual parameters in Table 2.(in page 29)

AC input voltage range	Narrow 	If selected, acceptable AC input voltage range will be within 184-272VAC.
	Wide 	If selected, acceptable AC input voltage range will be within 105-272VAC.
	APP-VDE4105 	If selected, acceptable AC input voltage range will conform to VDE4105.
Power saving(Search) mode enable/disable	Saving mode disable(default) 	If disabled, no matter connect load is low or high, the on/off status of inverter output will not be effected.
	Saving mode enable 	If enable, the inverter begins search mode if the AC load connected is pretty low or not detected. The inverter's "search" mode reduces stand-by energy consumption during no-load conditions.
Setting the min voltage point		PL: when the battery voltage is lower than the setting point, the inverter will start to recharge the battery.
		FL: when the battery voltage is lower than the setting point, the inverter will start to recharge the battery.
		FS: when the battery voltage is lower than the setting point, the inverter will start to recharge the battery.
		UPS: no use.
		PO: when the battery voltage is lower than the setting point, the inverter will start to recharge the battery.
Setting the balance voltage point		PL: when the battery voltage is higher than the setting point, the inverter will supply the power match the load, don't sell power back to grid. When the battery voltage is lower than the setting point, the inverter will stop discharging from battery.
		FL: when the battery voltage is higher than the setting point, the inverter will supply the power match the load, don't sell power back to grid. When the battery voltage is lower than the setting point, the inverter will stop discharging from battery.

		<p>FS: when the battery voltage is higher than the setting point, the inverter will discharging with max current. When the battery voltage is lower than the setting point, the inverter will stop discharge from battery.</p> <p>UPS: when the battery voltage is lower than the setting point, the inverter will start to recharge the battery.</p> <p>PO: When the battery voltage is lower than the setting point, the inverter will back to the grid. When the battery voltage is higher than the setting point, the inverter will stop charging to battery.</p>
Setting the max voltage point		<p>PL: In this mode, when the battery voltage is higher than the setting point, the inverter will sell power to the grid. When the battery voltage falls to the setting voltage below, the inverter will discharge match the load.</p> <p>FL: In this mode when the battery voltage is higher than the setting point, the inverter will discharge match the load.</p> <p>FS: In this mode when the battery voltage is higher than the setting point, the inverter will start selling power to the grid.</p> <p>UPS: In this mode when the battery voltage is higher than the setting point, the inverter will stop charging to battery.</p> <p>PO: When the battery voltage is higher than the setting point, the inverter will back to the off grid state.</p>
low DC cut-off voltage		48V model default setting: 42.0V Setting range is from 40.0V to 48.0V. Increment of each click is 0.1V. Low DC cut-off voltage will be fixed to setting value no matter what percentage of load is connected.
low DC recovery voltage		If the inverter is in the low voltage fault state of the battery, the battery voltage higher than the voltage, inverter will remove the battery low voltage fault.
High DC cut-off voltage		48V model default setting: 60.0V Setting range is from 58.0V to 60.0V. Increment of each click is 0.1V. High DC cut-off voltage will be fixed to setting value no matter what percentage of load is connected.
Off-Grid enable	On(default) 	Turn on the inverter output when the grid is off.
	Off 	Shut down the inverter output when the grid is off.

Grid-use enable/disable	Grid-use enable [14] UEN	Enable the inverter to connect to an AC input source.
	Grid-use disable [14] Uds	Disable the inverter to connect to an AC input source.
Low battery voltage Protection mode	[15] UAL	If "Usually-Defined" is selected, low DC cut-off voltage and low DC Warning Return Voltage can be referred to the table 2 of the page 29 in this manual.
	User-Defined [15] USE	If "User-Defined" is selected, low DC cut-off voltage and low DC Warning Return Voltage can be set up by program 10 and 11 of the page 18 in this manual.
Output voltage	[16] 230 <sub>v</sub>	Set the output voltage amplitude.
Output frequency	[17] 50.0 <sub>Hz</sub>	50Hz.(default)
	[17] 60.0 <sub>Hz</sub>	60Hz.
Grid charge enable	[18] UCE	Enable grid charge.(default)
	[18] UCd	Disable grid charge.
Solar Charger working Switch	[4] ON	Open or close the Solar Charge Controller output .
	[4] OFF	
Battery type	[42] Pb	Select the battery type.(Lead acid or Lithium)
	[42] L	
Battery AH	[43] 200	Set the AH of the battery.

Solar Charger absorb voltage	[44] 500 <sup>v</sup>	Set the Absorb voltage.(Refer to the Charging Curve)
Solar Charger refloat voltage	[45] 548 <sup>v</sup>	Set the Refloat voltage.(Refer to the Charging Curve)
Solar Charger Float voltage	[46] 572 <sup>v</sup>	Set the Float voltage.(Refer to the Charging Curve)
Solar Charger max current	[47] 600 <sup>A</sup>	Set the max output current of the Solar Charge Controller.(Refer to the Charging Curve)
Solar Charger absorb current	[48] 100 <sup>A</sup>	Set the absorb current of the Solar Charge Controller.(Refer to the Charging Curve)
Solar Charger low DC cut-off voltage	[49] 340 <sup>v</sup>	If the battery voltage is lower than the set point, the Solar Charge Controller will close the output.
Solar Charger high DC cut-off voltage	[50] 600 <sup>v</sup>	If the battery voltage is higher than the set point, the Solar Charge Controller will close the output.
Auto restart when overload occurs	[61] L+E	Restart enable.(default)
	[61] L+d	Restart disable.
Auto restart when over temperature occurs	[62] t+E	Restart enable.(default)
	[62] t+d	Restart disable.
Overload bypass: When enabled, the unit will transfer to line mode if overload occurs in battery mode	[63] b+E	Bypass enable.(default)
	[63] b+d	Bypass disable.

Auto turn page	[64] PLE	If selected, the display screen will auto turn the display page.
	[64] PLd	If selected, the display screen will stay at latest screen until user turns keys on.
Backlight control	[67] LOn	Backlight on.(default)
	[67] LOF	Backlight off.
Record Fault code	[68] FOn	Record disable.(default)
	[68] FOf	Record enable.

\* 09 > 08 > 07 max voltage > balance voltage point > the min voltage point.

\* 11 > 10 DC recovery voltage > low DC cut-off voltage.

\* 46 > 45 > 44 solar changer float voltage > solar changer refloat voltage > solar changer absorb voltage.

## Display Setting

The LCD display information will be switched in turns by pressing "UP" or "DOWN" key. The selectable information is switched as below order: battery voltage, battery current inverter voltage, inverter current, grid voltage, grid current, load in Watt, load in VA, grid frequency, inverter frequency, PV voltage, MPPT charging power, MPPT charging output voltage, MPPT charging current.

Selectable information	LCD display	
Battery voltage/Battery current	<sup>BATT</sup> 520 <sub>V</sub>	58 <sub>A</sub>
Inverter output voltage/Inverter output current	229 <sub>V</sub>	130 <sub>A</sub>
Grid voltage/Grid current	229 <sub>V</sub>	<sup>GRID</sup> 80 <sub>A</sub>
Load in Watt/VA	100 <sup>KW</sup>	<sup>LOAD</sup> 120 <sub>KVA</sub>
Grid frequency/Inverter frequency	<sup>INPUT</sup> 500 <sub>Hz</sub>	<sup>INV</sup> 500 <sub>Hz</sub>
PV voltage and power	<sup>PV</sup> 120 <sub>V</sub>	200 <sup>KW</sup>
PV charger output voltage and current	<sup>PV</sup> 510 <sub>V</sub>	<sup>OUTPUT</sup> 400 <sub>A</sub>





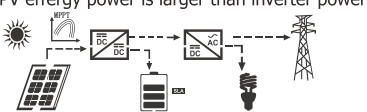
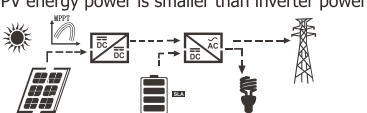
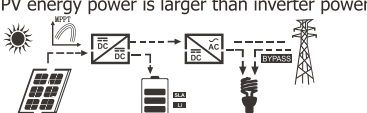
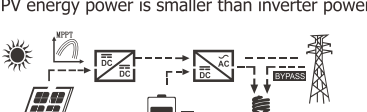
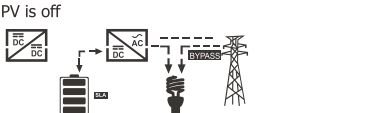
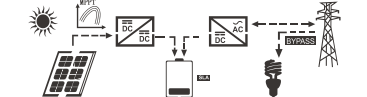
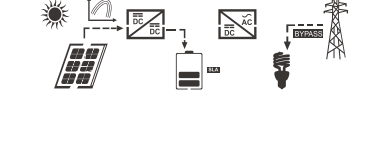
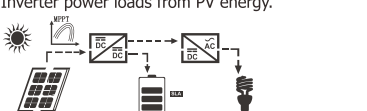
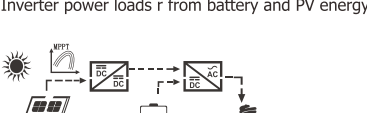
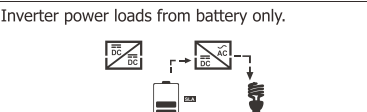



























## Operating State Description

Operation state	Description	LCD display
<p>sell state</p> <p>Note:</p> <p>The system generates electricity when it has sufficient sunshine supplying power to your home and sending any excess power back to the grid.</p>	<p>PV energy is sold back to grid.</p>	<p>PV energy power is larger than inverter power</p> 
		<p>PV energy power is smaller than inverter power</p> 
<p>Match load state</p> <p>Note:</p> <p>DC power produced from your solar array is converted by the inverter into AC power, which is then sent to your main electrical panel to be used by your household appliances. Any excess power generated is not sold back to the grid, but stored in battery.</p>	<p>PV energy is charger into the battery or converted by the inverter to the AC load.</p>	<p>PV energy power is larger than inverter power</p> 
		<p>PV energy power is smaller than inverter power</p> 
		<p>PV is off</p> 
<p>Charge state</p>	<p>PV energy and grid can charge batteries.</p>	
<p>Bypass state</p>	<p>Error are caused by inside circuit error or external reasons such as over temperature, output short circuited and so on.</p>	
<p>Off-Grid state</p>	<p>The inverter will provide output power From battery and PV power.</p>	<p>Inverter power loads from PV energy.</p> 
		<p>Inverter power loads r from battery and PV energy.</p> 
		<p>Inverter power loads from battery only.</p> 























Stop mode	The inverter stop working if you turn off the inverter by the soft key or error has occurred in the condition of no grid.	
-----------	---	--

**Fault Reference Code**

Fault Code	Fault Cause	LCD Indication
01	Fan is locked when inverter is off	
02	Inverter transformer over temperature	
03	battery voltage is too high	
04	battery voltage is too low	
05	Output short circuited	
06	Inverter output voltage is high	
07	Overload time out	
08	Inverter bus voltage is too high	
09	Bus soft start failed	
11	Main relay failed	
21	Inverter output voltage sensor error	
22	Inverter grid voltage sensor error	
23	Inverter output current sensor error	
24	Inverter grid current sensor error	
25	Inverter load current sensor error	

26	Inverter grid over current error	[26] 
27	Inverter radiator over temperature	[27] 
31	Solar charger battery voltage class error	[31] 
32	Solar charger current sensor error	[32] 
33	Solar charger current is uncontrollable	[33] 
41	Inverter grid voltage is low	[41] 
42	Inverter grid voltage is high	[42] 
43	Inverter grid under frequency	[43] 
44	Inverter grid over frequency	[44] 
51	Inverter over current protection error	[51] 
52	Inverter bus voltage is too low	[52] 
53	Inverter soft start failed	[53] 
55	Over DC voltage in AC output	[55] 
56	Battery connection is open	[56] 
57	Inverter control current sensor error	[57] 
58	Inverter output voltage is too low	[58] 

## WARNING INDICATOR

Warning Code	Warning Event	Icon flashing
61	Fan is locked when inverter is on	
62	Fan2 is locked when inverter is on	
63	Battery is over-charged	
64	Low battery	
67	Overload	
70	Output power derating	
72	Solar charger stops due to low battery	
73	Solar charger stops due to high PV voltage	
74	Solar charger stops due to over load	
75	Solar charger over temperature	
76	PV charger communication error	
77	Parameter error	
80	CAN fault	
81	Host loss	
82	Synchronization loss	
83	Battery voltage detected different	
84	AC input voltage and frequency detected different	
85	AC output current unbalance	
86	AC output mode setting is different	
87	Power feedback protection	
88	Firmware version inconsistent	
89	Current sharing fault	
90	CAN ID setting Error	

# SPECIFICATIONS

Table 1 Line Mode Specifications

INVERTER MODEL	9KW	10KW	12KW
Input Voltage Waveform	Sinusoidal(utility or generator)		
Nominal Input Voltage	120Vac or 230Vac		
Low Loss Voltage	65Vac ± 7V or 95 Vac ± 7V(SLO) 95Vac±7V or 174Vac±7V(FST) 95Vac ± 7V or 186Vac ± 7V(APL)		
Low Loss Return Voltage	70Vac±7V or105Vac±7v(SLO) 100Vac±7V or184Vac±7V(FST) 100Vact7V or 196Vac±7V(APL)		
High Loss Voltage	140Vac±7V or272Vac±7V(SLO,FST) 140Vac±7V or 253Vac±7V(APL)		
High Loss Return Voltage	135Vac±7V or265Vac±7V(SLO,FST) 135Vac±7V or 250Vac±7V(APL)		
Max AC Input Voltage	150Vac or 300Vac		
Nominal Input Frequency	50Hz / 60Hz		
Low Loss Frequency	40±1HZ(FST or SLO)/47.5 ±0.05HZ(APL)		
Low Loss Return Frequency	42±1HZ(FST or SLO)/47.5 ±0.05HZ(APL)		
High Loss Frequency	65±1HZ(FST or SLO)/51.5 ±0.05HZ(APL)		
High Loss Return Frequency	63±1HZ(FST or SLO)/50.05 ±0.01HZ(APL)		
Output Short Circuit Protection	Line mode:Circuit Breaker Battery mode:Electronic Circuits		
Transfer Time	<20ms		
Output power derating: When AC input voltage drops to 120V or 230V depending on models,the output power will be derated	<p>120Vac model:</p> <p>230Vac model:</p>		

Table 2 Inverter Mode Specifications

INVERTER MODEL	9KW	10KW	12KW
Rated output power	9000W	10000W	12000W
Output Voltage Waveform	Pure Sine Wave		
Output Voltage Regulation single-phase unit/three-phase unit	230Vac(L-N)/ 230Vac(P-N)		
Output Frequency	50Hz / 60Hz		
Peak Efficiency	≥93%		
Overload Protection	immediately @Short circuit; 10 seconds@load > 150%; 30 seconds@125% < load ≤ 150%; 60 seconds@110% < load ≤ 125%; 30 minutes@100% < load ≤ 110%		
Surge Capacity	2* rated power for 5 seconds		
Nominal DC Input Voltage	48Vdc		
Cold Start Voltage	46.0Vdc		
Low DC Warning Voltage @ load < 20% @ 20% ≤ load < 50% @ load ≥ 50%	44.0Vdc 42.8Vdc 40.4Vdc		
Low DC Warning Return Voltage @ load < 20% @ 20% ≤ load < 50% @ load ≥ 50%	46.0Vdc 44.8Vdc 42.4Vdc		
Low DC Cut-off Voltage @ load < 20% @ 20% ≤ load < 50% @ load ≥ 50%	42.0Vdc 40.8Vdc 38.4Vdc		
High DC Recovery Voltage	58Vdc		
High DC Cut-off Voltage	60Vdc		
Rated output current the single-phase unit/the three- phase unit	3*13A/13A per phase	3*14.3A/14.3A per phase	3*17.4A/17.4A per phase
Dynamic response speed (0→100%)	20ms		
Rate of wave distortion (THD) (Linearity loads)	Off grid ≤ 2%; Grid discharge ≤ 3%; Grid charge ≤ 3%		
Power factor	Grid discharge 99.9% & Grid charge 99.9%		
No-load power consumption	70W		120W

Table 3 Charge Mode Specifications

Grid Charging Mode			
INVERTER MODEL	9KW	10KW	12KW
Maximum Grid charging current(DC) the single-phase unit/the three-phase unit	3*60A		3*80A
Absorption Voltage	Pb	50.0V	
	Li	52.8V	
Refloat Voltage	Pb	54.8V	
	Li	53.6V	
Float Voltage	Pb	57.2V	
	Li	54.0V	
Solar Charging Mode			
INVERTER MODEL	9KW	10KW	12KW
Rated Power	3*3KW		
Efficiency	98.0% max		
Max.PV Array Open Circuit Voltage	145Vdc		
PV Array MPPT Voltage Range	64Vdc-130Vdc		
Min Battery Voltage For PV Charge	34Vdc		
Battery Voltage Accuracy	+/-0.3%		
PV Voltage Accuracy	+/-2V		
Charging Algorithm	Pb:3-Step;Li:4-Step		
Temperature Compensation Coefficient	-3mv/°C/cell(25°C ref)		
Charging algorithm for lead acid battery	<p>The graph shows the charging profile for a lead acid battery. The top part of the graph plots Voltage (red line) against Time, with three stages: Bulk, Absorption, and Float. In the Bulk stage, the voltage rises from the Absorb Voltage to the Float Voltage. In the Absorption stage, the voltage remains constant at the Float Voltage while the current decreases. In the Float stage, the voltage remains constant at the Float Voltage and the current is very low. The bottom part of the graph plots Current (green line) against Time. The Max Current is constant during the Bulk stage and then decreases during the Absorption stage. The Absorb Current is constant during the Bulk stage and then decreases during the Absorption stage. The Float Current is constant and very low during the Float stage.</p>		
Charging algorithm for Lithium battery	<p>The graph shows the charging profile for a Lithium battery. The top part of the graph plots Voltage (red line) against Time, with four stages: Absorb CC, Absorb CV, Float CC, and Float CV. In the Absorb CC stage, the voltage rises from the Absorb Voltage to the Float Voltage. In the Absorb CV stage, the voltage remains constant at the Float Voltage while the current decreases. In the Float CC stage, the voltage remains constant at the Float Voltage and the current is very low. In the Float CV stage, the voltage remains constant at the Float Voltage and the current is very low. The bottom part of the graph plots Current (green line) against Time. The Max Current is constant during the Absorb CC stage and then decreases during the Absorb CV stage. The Absorb Current is constant during the Absorb CC stage and then decreases during the Absorb CV stage. The Float Current is constant and very low during the Float CC and Float CV stages.</p>		

Goint Grid and Solar Charging		
Max Charging Current	3*60A	3*80A
Default Grid Charging	3*60A	3*80A
Default Solar Charging Current	3*60A	

Table 4 General Specifications

INVERTER MODEL	9KW	10KW	12KW
Safety Certification	CE		
Dimension(W*H*D),mm	391*836*555		
Net Weight,kg	129		145.5
Operating Temperature Range	0°C to +55°C		
Storage temperature	-15°C to +60°C		
Ambient humidity	0 to 90% relative humidity(non-condensing)		
Environmental Protection Rating	IP20		
Altitude	<2000m		



## TROUBLE SHOOTING

Problem	LCD/LED	Explanation / Possible cause	What to do	
Unit shuts down automatically during startup process.	Fault code 04	The battery voltage is too low. (<1.91V/Cell)	1. Re-charge battery. 2. Replace battery.	
No response after power on.	No indication.	1. The battery voltage is far too low. (<1.4V/Cell) 2. Battery polarity is connected reversed.	1. Check if batteries and the wiring are connected well. 2. Re-charge battery. 3. Replace battery.	
Mains exist but the unit works in battery mode.	Input voltage is displayed as 0 on the LCD and green LED flashing.	Input protector is tripped.	Check if AC breaker is tripped and AC wiring is connected well.	
	Green LED is flashing	Insufficient quality of AC power. (Shore or Generator)	1. Check if AC wires are too thin and/or too long. 2. Check if generator (if applied) is working well or if input voltage range setting is correct. (Appliance → Wide)	
When the unit is turned on, internal relay is switched on and off repeatedly	LCD display and LED are flashing.	Battery is disconnected.	Check if battery wires are connected well.	
Red LED is on.	Fault code 07	Overload error. The inverter is overload 110% and time is up.	Reduce the connected load by switching off some equipment.	
	Fault code 05	Output short circuited.	Check if wiring is connected well and remove abnormal load.	
			Check whether the air flow of the unit is blocked or whether the ambient temperature is too high.	
	Fault code 02	Internal temperature of inverter component is over 160°C .	Battery is over-charged.	Return to repair center.
	Fault code 03	The battery voltage is too high.	Check if spec and quantity of batteries are meet requirements.	
	Fault code 01	Fan fault	Replace the fan.	
	Fault code 06/58	Output abnormal (Inverter voltage below than 202 Vac or is higher than 253 Vac)	1. Reduce the connected load. 2. Return to repair center	
	Fault code 08/09/57	Internal components failed.	Return to repair center.	
	Fault code 51	Over current or surge.	Restart the unit, if the error happens again, please return to repair center.	
	Fault code 52	Bus voltage is too low.		
Fault code 55	Output voltage is unbalanced.			
Fault code 56	Battery is not connected well or fuse is burnt.	If the battery is connected well, please return to repair center.		

	Fault code 80	CAN data loss	1.Check if communication cables are connected well and restart the inverter. 2.If the problem remains, please contact your installer.
	Fault code 81	Host data loss	
	Fault code 82	Synchronization data loss	
	Fault code 83	The battery voltage of each inverter is not the same.	1.Make sure all inverters share same groups of batteries together. 2.If the problem remains, please contact your installer.
	Fault code 84	AC input voltage and frequency are detected different	1.Check the grid wiring connection and restart the inverter. 2.If the problem remains, please contact your installer.
	Fault code 85	AC output current unbalance	1.Restart the inverter. 2.If the problem remains, please contact your installer
	Fault code 86	AC output mode setting is different	1.Switch off the inverter and check the DIP switch setting. 2.If the problem remains, please contact your installer.
	Fault code 87	Current feedback into the inverter is detected.	1.Restart the inverter. 2.If the problem remains, please contact your installer.
	Fault code 88	The firmware version of each inverter is not the same.	1.Update all inverter firmware to the same version. 2.If the problem remains, please contact your installer.
	Fault code 89	The output current of each inverter is different.	1.Check if sharing cables are connected well and restart the inverter. 2.If the problem remains, please contact your installer.
	Fault code 90	CAN ID setting Error	1.Switch off the inverter and check the DIP switch setting. 2.If the problem remains, please contact your installer.

## APPENDIX: APPROXIMATE BACK-UP TIME TABLE

Model	Load(W)	Back Time@48Vdc 400Ah(min)	Back Time@48Vdc 600Ah(min)
9KW	900	1082	1674
	1800	484	811
	2700	311	501
	3600	213	363
	4500	170	273
	5400	142	213
	6300	113	183
	7200	99	149
	8100	88	132
12KW	9000	68	102
	1200	811	1217
	2400	363	563
	3600	213	363
	4800	149	256
	6000	119	192
	7200	85	149
	8400	73	109
	9600	64	96
10800	56	85	
12000	51	76	

**Notice:** Backup time depends on the quality of the battery, age of battery and type of battery. Specifications of batteries may vary depending on different manufacturers.

# USER'S MANUAL

ENERGY STORAGE INVERTER

Please download the software "Wincc" .



China:<https://cn.must-ee.com>



Oversea:<https://en.must-ee.com>