

VEICHI

Technical manual AC300 Series Frequency Inverter

VEICHI

Shenzhen Veichi Electric Co., Ltd.

Address: Third Floor, Building ChunSheng, Lingya Industrial Park, No. 1 Road,
Shiyan Tangtou Community, Bao'an District, Shenzhen

Phone: +86-755-3686 1688

Fax: +86-755-2968 5680

Suzhou Veichi Electric Co., Ltd.

Address: No. 1000 Songjia road, Wuzhong Economic and Technological Development
Zone, Suzhou

Phone: +86-512-6617 1988

Facebook: <https://www.facebook.com/veichiglobal/>

Whatsapp: +86-138 2881 8903

E-mail: overseas@veichi.com

Web: <http://www.veichi.org>



Wechat Official Account

Version: 2018 V1.0
Shenzhen Veichi Electric Co., Ltd. all rights
reserved, subject to change without notice.

CONTENT

CHAPTER 1 OVERVIEW 1

CHAPTER 2 BEFORE USE 7

CHAPTER 3 INSTALLATION AND WIRING 9

CHAPTER 4 BASIC OPERATION AND TRIAL RUN 30

CHAPTER 5 FAULT DIAGNOSES AND PROCESSING..... 33

CHAPTER 6 PERIODIC OVERHAUL AND MAINTENANCE 44

CHAPTER 7 PERIPHERAL EQUIPMENTS AND OPTIONS..... 48

CHAPTER 8 FUNCTION PARAMETER SPECIFICATIONS 53

CHAPTER 9 FUNCTION PARAMETER TABLE..... 149

APPENDIX 1: AC300 IO EXPANSION CARD MANUAL 177

APPENDIX 2 : PG CARD MANUAL..... 181

Chapter 1 Overview

Thanks for purchasing the AC300 series vector control inverter which designed and manufactured by VEICHI Electric. This manual describes how to use this product correctly for good returns. Please read this manual carefully before using the product (installation, wiring, operation, maintenance, inspection, etc.). In addition, please use this product after fully understanding the safety precautions described in this manual.

1.1 Safety requirement and cautions

Please use the product after fully understanding the safety precautions described in this manual to ensure safe, reliable and reasonable use of this product.

Warning signs and meanings

This manual has used following signs which means there is an important part of security. While observing against the rules, there is a danger of injury even death or machine system damage.





 Danger	Danger: Wrong operation may cause death or large accident.
 Warn	Warning: Wrong operation may cause death or large safety incident.
 Caution	Caution: Wrong operation may cause minor wound.
 Important	Important: Wrong operation may cause damage to this product and associated systems.



Figure 1-1 AC300 series inverter shell warning mark position

Operation requirement



Only professionally trained persons can be allowed to operate the equipment. "Professional trained persons "means the workers must have experience professional trained skill, and must be familiar with installation, wiring, running and

maintain and can rightly deal with emergency cases in use.



Safety guidance

Safety rules and warning signs come for your security. They are measures to prevent the operator and machine system from damage. Please carefully read this manual before using and strictly observe the regulations and warning signs while operating. Safety rules and warning signs are divided into the following categories: general guidance, guidance for transportation and storage, instructions for installation wiring, instructions for operation, instructions for maintenance, and guidance for disassembly and disposal.



General guidance

	<ul style="list-style-type: none"> This product carries dangerous voltage and controls driver machine with potential danger. If you don't abide by the regulations or requirements in this manual, there is danger of body injury even death and machine system damage. Only trained personnel are allowed to operate this product. Before using this product, please be familiar with all the safety and operating instructions in this manual. Correct operation and maintenance is a reliable guarantee of this product. Do not wire while the power is connected. Otherwise, there is danger of death for electric shock. Before wiring, inspection and maintenance, please cut off power supply of all related equipment's and ensure main DC voltage in safe range. And please operate it after 5 mins.
	<ul style="list-style-type: none"> Prevent children and the public from near the product. This product can only be used in accordance with the manufacturer's intended, and may not be used in special fields such as emergency, rescue, shipbuilding, medical, aviation, nuclear facilities, etc. without permission. Unauthorized modifications and use of spare parts recommended by the manufacturer of this product may result faults.
	<ul style="list-style-type: none"> Be sure to deliver this manual to the actual user so that the actual user can read this manual carefully before use. Before installing and debugging the inverter, please be sure to read and fully understand these safety rules and warning signs.

Transportation and storage instructions

	<ul style="list-style-type: none"> Correct transportation, store, installation, careful operation and maintenance are important for inverter safe operation.
	<ul style="list-style-type: none"> In transport and store process, make sure the inverter is free from impact and vibration. It must be stored where is dry without corrosive air and conductive dust, and the temperature must be lower than 60°C.

Guide to installing wiring

	<ul style="list-style-type: none"> Only trained professionals can operate this product. Power wire, motor wire and control wire should be all connected firmly. Earth must be reliable and earth resistance must be lower than 10Ω. Before turning on the inverter panel, please cut off the power of all related equipment and confirm that the DC voltage of the main circuit has dropped to a safe level. Wait for 5 minutes before related operations. Human body electrostatic will damage inner sensitive components seriously. Before operation, please follow ESD measures. Otherwise, there is danger of inverter damage. Inverter output voltage is pulse wave. If components such as capacitor which improves power factor and pressure-sensitive resistance for anti-thunder and so on are installed at the output side, please dismantle them or change to input side. No switch components such as breaker and contactor at the output side (If there must be one, please make sure the output current is 0 while the switch acting).
	<ul style="list-style-type: none"> The power cable and motor cable specifications which connected to the inverter must meet the conditions shown in Table 3-7 3-8 of this manual.

Operational guidance

	<ul style="list-style-type: none"> The frequency inverter operation at high voltages , dangerous voltages are inevitably present on certain parts of the product. Regardless of where the fault occurs in the control device, it can cause major accidents or even personal injury and potentially dangerous faults. Therefore, additional external precautions or other means for ensuring safe operation must be taken, for example: Install independent current limiting switch, mechanical protection and other devices. In order to ensure that the overload protection of the motor can operate correctly, the motor parameters of the input inverter must be similar to the actual motor .
--	--

Maintenance guidance

	<ul style="list-style-type: none"> Only Veichi Electric co., ltd service department or its authorized service center can maintain the products. It may cause product fault while using accessories not authorized or permitted. Any defective components must be changed in time in maintenance. Before turning on the equipment for maintenance, make sure to disconnect the power supply and confirm that the DC voltage of the main circuit has dropped to a safe level. Wait 5 minutes before related work.
--	--

Guidance on disassembly and waste disposal

	<ul style="list-style-type: none"> The package of the inverter can be reused. Please keep the package for future use or return it to the manufacturer. The removed metal parts can be recycled. Some devices may badly affect the environment, such as electrolytic capacitors, please handle devices in accordance with the requirements of the environmental protection department.
---	--

1.2 Technical Specifications

Table 1-1: Technical Specifications

Items		Specifications			
Power input	Voltage, frequency	Single phase 220V Three phase 220V Three phase 1140V	50/60Hz 50/60Hz 50/60Hz	Three phase 380V Three phase 660V Three phase 480V	50/60Hz 50/60Hz 50/60Hz
	Allowable fluctuations	voltage unbalance rate:<3%; Frequency:±5%; aberration rate: as IEC61800-2 required			
	Inrush current	Lower than rated current			
	Power factor	≥0.94(with DC reactor)			
	Efficiency	≥96%			
Output	Output voltage	Output under rated condition: 3 phase, 0~input voltage, inaccuracy<5%			
	Output frequency range	G/P type:0~600Hz			
	Output frequency	Max frequency ±0.5%			
	Overload capacity	G type: 150% rated current/1 min, 180% rated current/10s, 200% rated current/0.5s P type: 120% rated current/1 min, 140% rated current/10s, 150% rated current/0.5s			
Main Controller performance	Motor control mode	V/F without PG, VC without PG, V/F with PG, VC with PG			
	Modulation mode	Optimized SVPWM mode			
	Carrier frequency	0.7~16.0kHz			
	Speed control range	VC without PG: rated load 1:100; VC with PG: rated load 1:1000			
	Steady speed accuracy	VC without PG: ≤2% rated synchronized speed; VC with PG: ≤0.05% rated synchronized speed			
	Starting torque	VC without PG: when 0.5Hz, 150% rated torque; VC with PG: when 0Hz,			
	Torque response	VC without PG: ≤20ms; VC with PG: ≤10ms			

Basic functions	Frequency accuracy	Digit setting: max frequency×±0.01%; Analog setting: max frequency×±0.2%
	Frequency resolution	Digit setting: 0.01Hz; Analog setting: max frequency×0.05%
	DC braking capacity	Starting frequency:0.00~50.00Hz; Braking time:0.0~60.0s; Braking current:0.0~150.0% rated current
	Torque boost	Auto torque upgrade 0.0%~100.0%; Manual torque upgrade 0.0%~30.0%
	V/F curve	4 modes: one linearity torque characteristic curve ,one self-setting V/F curve mode, one drop torque characteristic curve (1.1- 2.0 powers),and square V/F curve mode.
	Acceleration/Deceleration curve	2 modes: linear Acceleration/Deceleration and S curve Acceleration/Deceleration. 4 sets of ACC/DEC, time unit 0.01s selectable, longest time: 650.00s.
	Rated output voltage	Rely on power supply voltage compensate function, while motor rated voltage is 100%, set it at the range of 50-100%(output can not over input voltage).
	Voltage auto-adjustment	While power supply voltage fluctuates, it can auto-keep constant output voltage.
	Auto energy-saving running	While under V/F control mode, according to load situation, auto-optimize output voltage to save energy.
	Auto-limit current	Auto-limit the current while running to prevent over current break trouble.
	Instant power off treatment	While instant power off, realize continual operation by bus voltage control.
	Standard functions	PID control, speed track, power off restart, jump frequency, upper/lower frequency limit control, program operation, multi- speed, RS485, analog output, frequency impulse output.
	Frequency setting channels	Keyboard digital setting, Analog voltage/current terminal AI1, Analog voltage/current terminal AI2, Communication given and multi-channel terminal selection, Main and auxiliary channel combination, expansion card, supporting different modes switch
	Feedback input channel	Voltage/Current Terminal AI1, Voltage/Current Terminal AI12, Communication given, Low-speed pulse input PUL, extension card
	Running command channel	Operation panel given, external terminal given, communication given, expansion card given
	Input command signal	Start, stop, FWD/REV, JOG, multi-step speed, free stop, reset, ACC/DEC time selection, frequency given channel selection, exterior fault alarm.
	Exterior output signal	1 relay output, 1 collector output, 1 AO output: 0~10V output or 4~20mA output, or frequency pulse output
	Protection function	Overvoltage, under-voltage, current limit, over-current, overload, electric thermal relay, overheat, overvoltage stall, data protection, rapid speed protection, input/output phase failure protection

Keyboard display	LED display	Single file 5 digital tube display	Can monitor one state variable
		Two file 5 digital tube display	Can monitor two state variables
	Parameter copy	Can upload or download function code information of inverter to realize fast parameter copy.	
	State monitor	Output frequency, given frequency, output current, input voltage, output voltage, motor speed, PID feedback, PID given value, module temperature etc. monitor parameters.	
Fault alarm	,Over-voltage, under-voltage, over-current, short circuit, phase failure, overload, overheat, overvoltage stall, current limit, or data protection destroyed; Fault running state; Fault history.		
Environment	Install place	altitude ≤ 1000m,above 1000m down the rated amount, each increase of 100m down the rated amount of 1%;no condensation, ice ,rain, snow, hail; solar radiation below 700W/m ² , air pressure 70-106 kPa	
	Temperature, humidity	-10→+50℃, above 40℃ down the rated amount, the max temperature:60℃ (no load running)	
	Vibration	9~200Hz,5.9m/s ² (0.6g) 5%—95%RH (no condensation)	
	Store temperature	-30→+60℃	
	Installation	Hanging type, cabinet type	
	Protection degree	IP20	
	Cooling mode	Forced air cooling	

Chapter 2 Before Use

2.1 Purchase Inspection

On receiving your order, please check the package and confirm intact before opening, and check if there's any damage, scratch or dirt (damages caused during transportation are not within the company's warranty). If there's any damage caused during transportation, please contact us or the transport company immediately.

After confirming the receipt of the goods intact, please re-confirm if the product and your order are consistent. Model of the product is on the "MODEL" column. If you find the product model is not the one you ordered, please contact the dealer you purchased the product or the sales department of VEICHI immediately.

2.2 Nameplate

Nameplate Position and Content

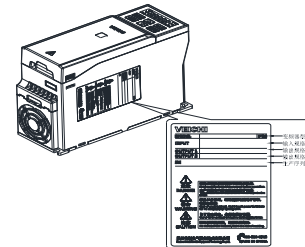

Model Specification

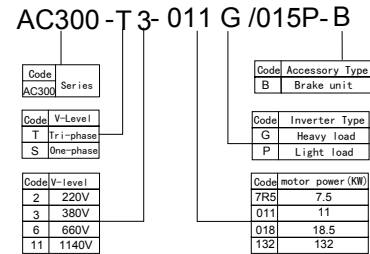

2.3 Inverter Rated Output Current

Input Voltage	220V	380V	660V	1140V
Rated Power	Rated Output Current (A)			
0.75	4	3		



Input Voltage	220V	380V	660V	1140V
Rated Power	Rated Output Current (A)			
1.5	7	4		
2.2	10	6.0		
4	16	10		
5.5	20	13		
7.5	30	17	10	
11	42	25	15	
15	55	32	18	
18.5	70	38	22	
22	80	45	28	
30	110	60	35	
37	130	75	45	25
45	160	90	52	31
55	200	110	63	38
75	260	150	86	52
90	320	180	98	58
110	380	210	121	75
132	420	250	150	86
160	550	310	175	105
185	600	340	198	115
200	660	380	218	132
220	720	415	235	144
250		470	270	162
280		510	330	175
315		600	345	208
355		670	380	220
400		750	430	260
450		810	466	270
500		860	540	325
560		990	600	365
630		1100	680	400

Chapter 3 Installation and Wiring

3.1 Safety Precautions

This chapter explains the warnings that must be followed to ensure that the user can safely use the product, maximize the performance of the inverter, and ensure reliable operation of the inverter.

Cautions in use:

	<ul style="list-style-type: none"> While install the inverter in the closed cabinet, please build in cooling fan, air-conditioner or other cooling equipment to ensure the temperature at the air-in port below 40°C. So that the inverter can work safely and reliably.
	<ul style="list-style-type: none"> While installing, please use cloth or paper cover the inverter to prevent metal dust, oil, water and others. And remove it carefully after working. While operation, please follow the ESD regulations. Otherwise, the inverter may be damaged. While multi inverters are installed in the same cabinet, enough space must be left for cooling fan. Inverter cannot work over rated range. Otherwise, the inverter may be damaged. While transporting the inverter, please hold the firm case. If only hold the pre-cover, there is danger of inverter main body falling, injury or inverter damage.

Cautions in use motor

	<ul style="list-style-type: none"> Different motor has different max allowable running speed. Motor can not run over the max allowable running speed. While inverter is running at low speed, the motor auto-cool effect is seriously worse. If motor runs at low speed for long time, it will be damaged for overheat. If needed, please use special motor for inverter. While constant speed machinery runs at inconstant speed, there maybe sympathetic vibration. Please install vibration-proof rubber under motor rack or use jumping frequency control function. While using frequency inverter or working frequency power supply to drive, the torque characteristic are different. Please do confirm the torque characteristic of the equipment connected. The rated current of diving motor is higher than that of standard motor, please confirm it and choose the right inverter. While the wire between motor and inverter is long, the max torque of the motor will reduce for voltage drop. So please use thick cable while the distance between the motor and the inverter is long.
--	---

3.2 Treatment for Inverter after Longtime Store

If the inverter store time is over one year, you must pre-charge the aluminum capacitor in the inverter again and install the inverter after the aluminum capacitor characteristic recovering. For the specific method, please follow the grads in the chart below and give corresponding proportional voltage for every grad more than 30 mins while the inverter is no-load.

If the input voltage of one grad is at the action critical point of contactor, fan or other equipment, please increase or reduce the corresponding input voltage for the grad to avoid any component working under critical state.



Chart 3-1: treatment for inverter after longtime store

3.3 Inverter Stable Running Environment

Installation environment is very important to the best use of this product for long time. Pls install this product in the environment as the following table requirement.

Table 3-1: Environmental conditions required for reliable operation of AC300 series inverters

Environment	Requirement
Install place	Indoor without direct sunshine
Install temperature	-10 ~ +40°C
Store temperature	-30 ~ +60°C
Humidity	<95%RH, no condensation
Surrounding	Please install the inverter in place as follows: <ul style="list-style-type: none"> Place without oil mist, corrosive gases, flammable gas, dust or etc. Place without metal dust, oil, water or etc into inverter (please do not install inverter on flammable material such as food and etc). Place without radioactive material or flammable material. Place without poisonous gases or liquid. Place with very little salification erosion. Place without direct sunshine.
Altitude	<1000m, down power for use over 1000 meters
Vibration	At 9 to 200 Hz, 5.9 m/s ² (0.6 g)

Installation and cooling	<ul style="list-style-type: none"> Inverter can not be installed horizontally must be installed vertically. Please independently install high heating equipment such as braking resistor and etc which can not be installed in the same cabinet with inverter, installed at the air-in port of the inverter is strictly prohibited.
--------------------------	---

• In order to improve the product stability, do please not use the inverter where temperature changes sharply. While using in closed space such as control cabinet, please use cooling fan or air-condition to cool inverter to avoid temperature over limit range. Please also prevent inverter from freeze, too low temperature may cause components freeze fault.

- Derate according to the chart while over temperature limit.

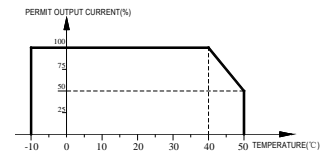

Chart 3-2:AC300 series inverter derating curve while over permit temperature

- Derate according to the chart while over altitude limit.

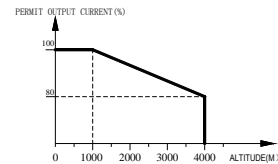



Chart 3-3:AC300 series inverter derating curve while over permit altitude

3.4 EMI Protection

The inverter is designed to be used in industrial environment with strong electromagnetic interference. Generally speaking, if the installation quality is good, it is ensured that the inverter can work safely without fault. Please install the inverter according to the following rules to ensure stable running and avoid electromagnetic interference impact.

- Ensure that all equipment in the cabinet have been connected reliably to the common Y-type earth point or earth bus with thick and short cable. The motor earth should be as close as possible. Please do not connect the motor case to the inverter earth terminal or the protective area of control system.
- Ensure that all equipment connected to the inverter have been reliably connected to the same earth net or Y-type earth point with thick and short cable.
- The conductor has better to be flat and with multi core, what has lower resistance at high frequency.

- The cutting terminal should be as soigne as possible. Unshielded wire section must be as short as possible.
- In control cable wiring, it should be as far from the power supply cable and motor cable as possible. And independent cable trough should be used. While the control cable must cross to the power supply cable or motor cable, it should be 90° vertical cross.
- Ensure that the contactor in the cabinet has wave suppresser. Or'R-C'damping circuit is connected to the winding of AC contactor. Voltage dependent resistor corresponding to the winding voltage is used. And freewheel diode or components such as voltage dependent resistor corresponding to the winding voltage are connected to DC contactor. It is very important while contactor, controlled by output relay of inverter, acts frequently.
- Cable connected to motor should be shielded cable or armoured cable. The two barriers are earthed reliably by cable grounding card.
- Build noise filters at the input side to reduce electromagnetic interference from other equipments at the power grid side. The noise filter should be as close to the inverter power input terminal as possible. Meantime, the filter must earth reliably as the inverter.
- Build noise filters at the output side to reduce radio interference and inductive disturbance. The noise filter must be as close to the inverter output terminal as possible. Meantime, the filter must earth reliably as the inverter.
- Anytime, control circuit wire should be shielded cable.
- Add zero phase reactor in power supply wire near inverter input terminal and add zero phase reactor in the motor wire near inverter output terminal to reduce electromagnetic interference to the inverter efficiently.
- Earthing Right and reliable earthing is the basic condition of safe and reliable running of the product. For right earthing, please read the following notice carefully.

	<ul style="list-style-type: none"> • In order to avoid electric shock, earthing cable should be the size as electric equipment technique standard required and cable length should be as short as possible. Otherwise, inverter leakage current will cause unstable potential of the earthing terminal which is far from the earthing point, and electric shock accident will happen frequently. • Earth terminal must be earthing. Earth resistance must be below 10Ω. Otherwise, there is danger of death.
	<ul style="list-style-type: none"> • Please do not share earth cable with welder or other big current/pulse power equipment. Otherwise, inverter will act abnormally. • While multi inverters are used at the same time, please do not wind the earth wire to loop-type. Otherwise, inverter will act abnormally.

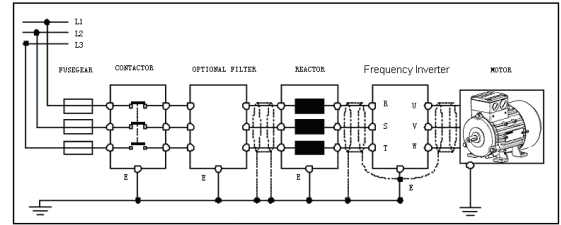

Chart 3-4:AC300 series inverter system grounding

Remark: motor must earth as close as possible. Motor case can not be connected to the inner earth terminal of the inverter. It also can not share the earth net with the control system.

Shield of inverter power cable, motor cable and control cable

Shielding layer (reticulate/armoured) should be wound reliably by cable earth card and fix to inverter earth piece by bolt. Please refer to the following chart.

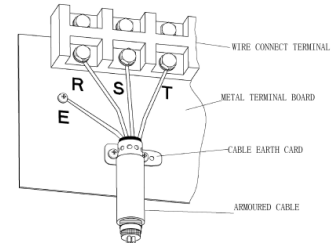

Chart 3-5: Cable earth card for cables grounding

Corresponding relationship between inverter/motor cable length and carrier frequency

While cable distance between inverter and motor is long (especially low frequency output), cable voltage drop will make motor torque reduce. Further more, cable HF leakage current will increase. Then inverter output current will increase, that will cause inverter over-current trip. The current detection accuracy and running stability will be impacted. Please follow as below table to adjust carrier frequency according to the cable length. While the cable distance is over 100m, please adopt distributed capacity reduce measure (Such as "no metal conductor covers cable", "wire each phase cable apart" and so on).

Cable length	<20m	20-50m	50-100m	>100m
Carrier frequency	0.7~16kHz	0.7~8kHz	0.7~4kHz	0.7~2kHz

3.5 Machinery Installation

Installation notice and related requirement:

- Installation direction**
 To prevent inverter cooling effect reducing, please do install the inverter vertically.
- Installation space**
 Single machine installation: to ensure enough ventilation and wiring space for inverter cooling, please follow installation conditions as follows. The back of the inverter should stick to the wall. So that the surrounding air of radiator can flow freely to ensure the cooling effect.

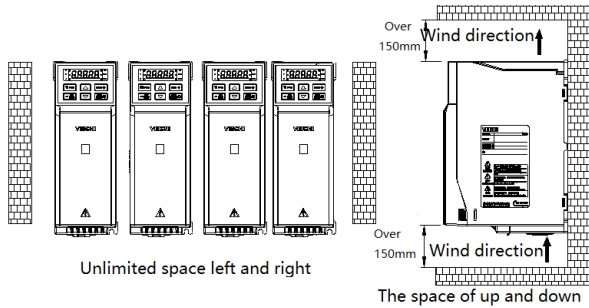
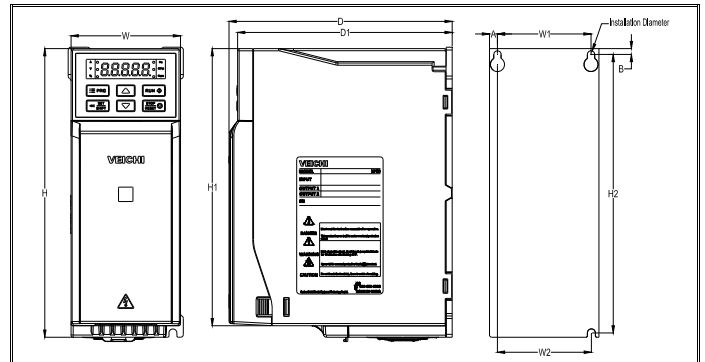
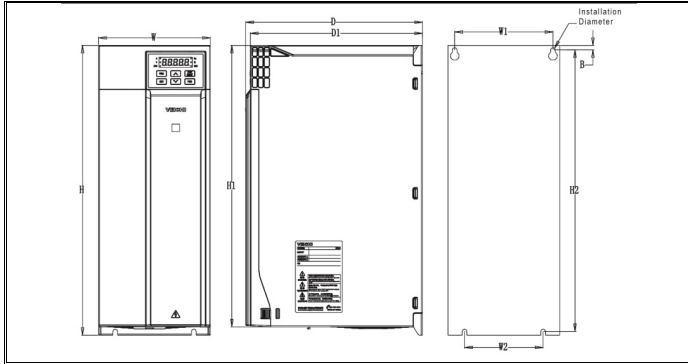

Chart 3-6: Inverters paratactic installation space requirement

Dimension of Inverter and Keyboard



MODEL	Overall Dimension(mm)					Installation Dimension(mm)					Aperture
	W	H	H1	D	D1	W1	W2	H2	A	B	
AC300-T/S2-R75G-B	76	200	192	155	149	65	65	193	5.5	4	φ3-M4
AC300-T/S2-1R5G-B											
AC300-T/S2-2R2G-B	100	242	231	155	149	84	86.5	231.5	8	5.5	φ3-M4
AC300-T/S2-004G-B											
AC300-T3-R75G/1R5P-B	76	200	192	155	149	65	65	193	5.5	4	φ3-M4
AC300-T3-1R5G/2R2P-B											
AC300-T3-2R2G-B											
AC300-T3-004G/5R5P-B	100	242	231	155	149	84	86.5	231.5	8	5.5	φ3-M4
AC300-T3-5R5G/7R5P-B											
AC300-T3-7R5G/011P-B	116	320	307.5	175	169	98	100	307.5	9	6	φ3-M5
AC300-T3-011G/015P-B											



MODEL	Overall Dimension(mm)				Installation Dimension(mm)				Aperture	
	W	H	H1	D	D1	W1	W2	H2		B
AC300-T3-015G/018P-B	142	383	372	225	219	125	100	372	6	φ4-M5
AC300-T3-018G/022P-B										
AC300-T3-022G/030P-B										
AC300-T3-30G/037P	172	430	/	255	219	150	150	416.5	7.5	φ4-M5
AC300-T3-037G/045P										

Overall Dimension of Inverter (Steel)

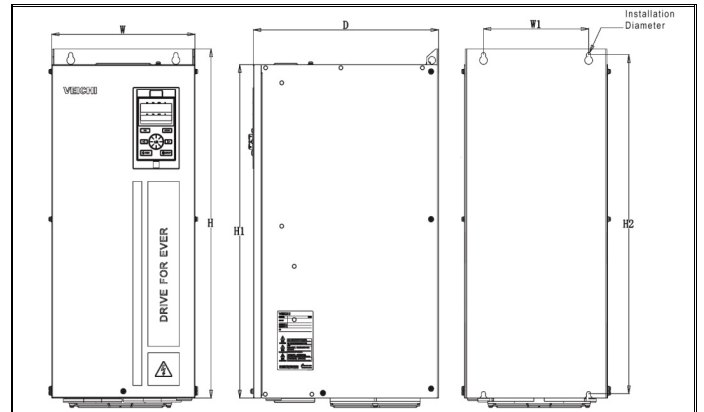

MODEL	Overall Dimension(mm)				Installation Dimension(mm)		Aperture
	W	H	H1	D	W1	H2	
AC300-T3-045G/055P	240	560	535	310	176	544	φ4-M6
AC300-T3-055G/075P							
AC300-T3-075G/090P							

External keyboard shape and opening size

Note: LCD is fully compatible with LED keyboard size and opening size.

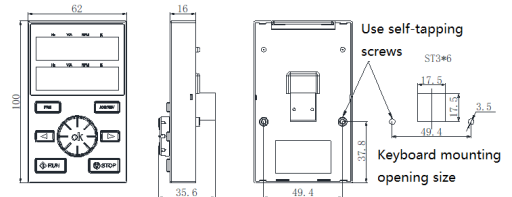

AC300 series keyboard and opening size

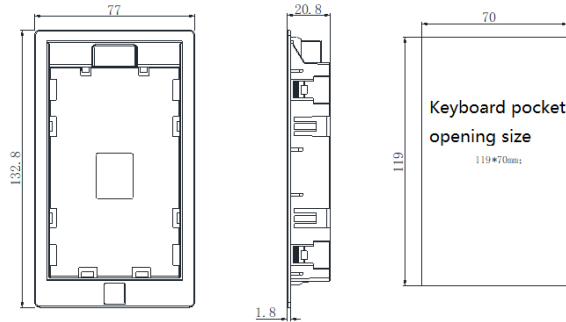

AC300 Keyboard pocket opening size

3.6 Electric Installation

This chapter explains the regulations that users have to obey to ensure safe use, best performance and reliable running.

Safety precaution

	<ul style="list-style-type: none"> Must earth reliably while inverter is running. Otherwise there is danger of casualty and unstable inverter performance. To ensure safe running, only trained professional person can do installation and wiring job. No operation under power connected state. Otherwise there is danger of electric shock even death. Before operation, please cut all related equipments power, ensure that the main circuit DC current has dropped to safe range. And please operate after 5 mins.
	<ul style="list-style-type: none"> Control cable, power cable and motor cable must be separated. They can not be in the same cable trough or cable rack. This equipment can only be used as the maker states. Please consult Veichi while using in special case.
	<ul style="list-style-type: none"> No insulation test for the inverter or the related cable by HV insulation test equipment. If the inverter or the peripheral equipment (filter, reactor and etc) needs insulation test, firstly 500V megohmmeter should be used to test the insulation resistance which should not be lower than 4MΩ.

Standard Connection Diagram

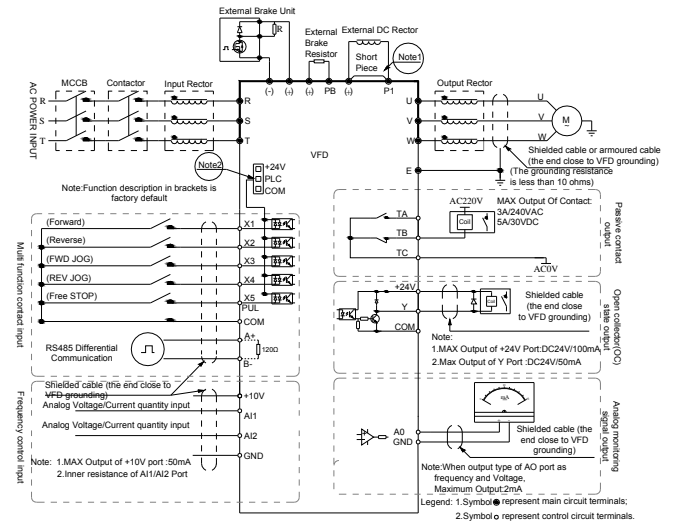

Chart 3-8:AC300 series inverter standard diagram

Note:

- When installing DC reactor, make sure to dismantle the short connector between terminal P1 and (+).
- NPN or PNP transistor signal can be selected as input of multi-function input terminal (X1-X5/PUL). Inverter built-in power supply (+24V terminal) or external power supply (PLC terminal) can be chosen as bias voltage. Factory setting '+24V' short connect with 'PLC', which locates between RJ45 and terminals.

- Auxiliary terminal output capacity

Terminal	Function definition	Max output
+10V	10V auxiliary power supply output, constitutes loop with GND.	50mA
A0	Analog monitor output, constitutes loop with GND.	As frequency,voltage signal, max output 2mA
+24V	24V auxiliary power supply output, constitutes loop with COM.	100mA
Y	Collector open circuit output, can set the action-object by program.	DC24V/50mA
TA/TB/TC	Passive connector output, can set the action-object by program.	3A/240VAC 5A/30VDC

• Function Specification of Switch Terminals

Switch Terminal	Selecting Position	Function Specification
RS485	OFF <input type="checkbox"/> ON <input type="checkbox"/>	RS485 Terminal Resistor RS485 Communication :connect with 120Ω terminal
AO-F	OFF <input type="checkbox"/> ON <input type="checkbox"/>	AO Output- frequency AO2: 0.0~100kHz frequency output
AO-I	OFF <input type="checkbox"/> ON <input type="checkbox"/>	AO Output- Current AO2: 0~20mA current output or 4~20mA current output
AO-U	OFF <input type="checkbox"/> ON <input type="checkbox"/>	AO Output- Voltage 0~10V voltage output
AI1	U <input type="checkbox"/> I <input type="checkbox"/>	AI1 Input- Current/Voltage AI1: Input 0~20mA or 0~10V
AI2	U <input type="checkbox"/> I <input type="checkbox"/>	AI2 Input- Current/Voltage AI2: Input 0~20mA or 0~10V

• Multi-function input point connection

PNP transistor connection mode:

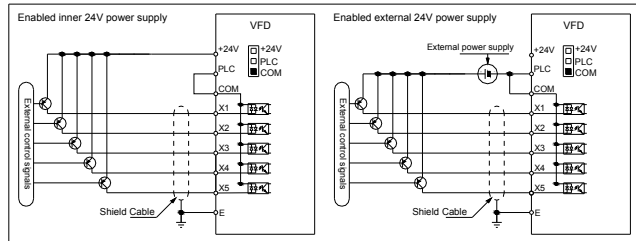

NPN transistor connection mode:

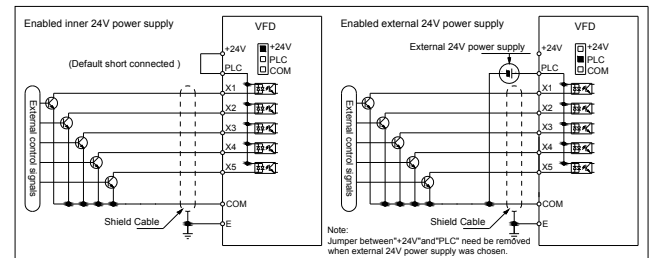

Jumper cap "+24V", "PLC", "COM" connection diagram:

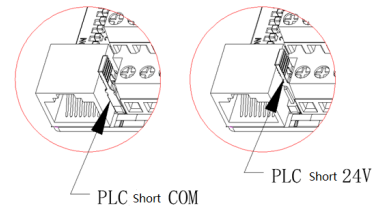

Main circuit wiring

• Main circuit wiring

Terminals array and definition:

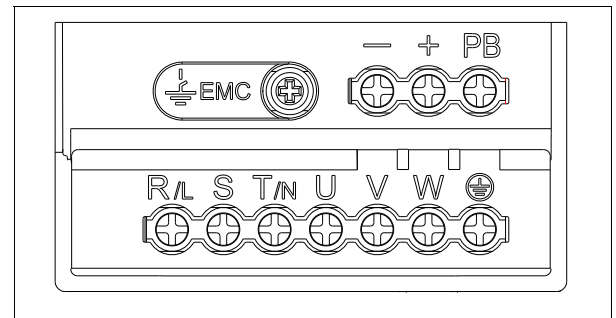

Table 3-3: Main circuit terminal arrangement and definition of AC300 series inverter

Terminal	Name	Definition
(-)	DC power terminal	DC power output, (-) means DC bus cathode, (+) means DC bus anode, used for external braking unit.
(+)		
(+)	Braking resistance terminal	Used for external braking resistance to realize quick stop.
PB		
P1	DC reactor terminal	Used for external DC reactor.
(+)		
R	Inverter input terminal	Used to connect 3-phase AC power supply.
S		
T		
U		
V	Inverter output terminal	Used to connect the motor.
W		
⊕		
E	Earth	Earth terminal, earth resistance<10 OHM

• 3-phase 380V machine main circuit wiring

Table 3-4: Suggested cable diameter and fixed moment 3-phase 380V machine main circuit

Model	Main circuit terminals screw specifications	Suggested fixed moment (N·m)	Suggested Copper-core cable specification mm ² (AWG)
AC300-T3-R75G	M4	1.2~1.5	1.5mm ² (14)
AC300-T3-1R5G	M4	1.2~1.5	2.5mm ² (12)
AC300-T3-2R2G	M4	1.2~1.5	2.5mm ² (12)
AC300-T3-004G	M4	1.2~1.5	4mm ² (10)
AC300-T3-5R5G	M4	1.2~1.5	6mm ² (9)
AC300-T3-7R5G	M5	2~2.5	6mm ² (9)
AC300-T3-011G	M5	2~2.5	10mm ² (7)
AC300-T3-015G	M6	4~6	10mm ² (7)
AC300-T3-018G	M6	4~6	16mm ² (5)
AC300-T3-022G	M6	4~6	16mm ² (5)
AC300-T3-030G	M8	8~10	25mm ² (3)
AC300-T3-037G	M8	8~10	25mm ² (3)
AC300-T3-045G	M8	8~10	35mm ² (2)
AC300-T3-055G	M10	11~13	35mm ² (2)

AC300-T3-075G	M10	11~13	50mm ² (1)
AC300-T3-090G	M10	11~13	50mm ² (1/0)
AC300-T3-110G	M10	11~13	70mm ² (2/0)
AC300-T3-132G	M10	11~13	95mm ² (3/0)
AC300-T3-160G	M12	14~16	95mm ² (4/0)
AC300-T3-185G	M12	14~16	120mm ²
AC300-T3-200G	M12	14~16	150mm ²
AC300-T3-220G	M12	14~16	150mm ²
AC300-T3-250G	M12	14~16	185mm ²
AC300-T3-280G	M12	14~16	185mm ²
AC300-T3-315G	M16	20~23	240mm ²
AC300-T3-355G	M16	20~23	240mm ²
AC300-T3-400G	M16	20~23	300mm ²
AC300-T3-450G	M16	20~23	400mm ²
AC300-T3-500G	M16	20~23	400mm ²
AC300-T3-560G	M16	20~23	500mm ²

Note:

- Here we suggest using copper joins as mains electric connectors of machine over 185KW. Please refer the cut section area above.

• Single-phase 220V machine main circuit wiring

Table 3-5: Suggested cable diameter and fixed moment single-phase 220V machine main circuit

Model	Main circuit terminals screw specifications	Suggested fixed moment (N·m)	Suggested Copper-core cable specification mm ² (AWG)
AC300-S2-R40G	M4	1.2~1.5	1.5mm ² (14)
AC300-S2-R75G	M4	1.2~1.5	2.5mm ² (12)
AC300-S2-1R5G	M4	1.2~1.5	2.5mm ² (12)
AC300-S2-2R2G	M4	1.2~1.5	4mm ² (10)

• Suggested main circuit components specification

Table 3-6: Suggested mains fittings for 3-phase 380V machine

Model	Contactor specification	Breaker specification	DC reactor	Input filter	Output filter
AC300-T3-R75G	10A	10A	-----	NFI-005	NFO-010
AC300-T3-1R5G	10A	10A	-----	NFI-005	NFO-010
AC300-T3-2R2G	16A	15A	-----	NFI-010	NFO-010
AC300-T3-004G	16A	20A	-----	NFI-010	NFO-010

AC300-T3-5R5G	25A	20A	-----	NFI-020	NFO-020
AC300-T3-7R5G	25A	30A	-----	NFI-020	NFO-020
AC300-T3-011G	32A	40A	-----	NFI-036	NFO-036
AC300-T3-015G	40A	50A	-----	NFI-036	NFO-036
AC300-T3-018G	50A	60A	-----	NFI-050	NFO-050
AC300-T3-022G	50A	75A	-----	NFI-050	NFO-050
AC300-T3-030G	63A	100A	DCL-80	NFI-080	NFO-080
AC300-T3-037G	80A	125A	DCL-100	NFI-100	NFO-100
AC300-T3-045G	100A	150A	DCL-110	NFI-100	NFO-100
AC300-T3-055G	125A	175A	DCL-125	NFI-150	NFO-150
AC300-T3-075G	160A	200A	DCL-150	NFI-150	NFO-150
AC300-T3-090G	220A	250A	DCL-200	NFI-200	NFO-300
AC300-T3-110G	220A	300A	DCL-200	NFI-200	NFO-300
AC300-T3-132G	250A	400A	DCL-300	NFI-300	NFO-300
AC300-T3-160G	300A	500A	DCL-300	NFI-300	NFO-300
AC300-T3-185G	400A	600A	DCL-400	NFI-400	NFO-400
AC300-T3-200G	400A	700A	DCL-400	NFI-400	NFO-400
AC300-T3-220G	630A	800A	DCL-500	NFI-600	NFO-600
AC300-T3-250G	630A	1000A	DCL-600	NFI-600	NFO-600
AC300-T3-280G	630A	1200A	DCL-600	NFI-600	NFO-600
AC300-T3-315G	630A	1200A	DCL-800	-----	-----
AC300-T3-355G	800A	1400A	DCL-800	-----	-----
AC300-T3-400G	1000A	1600A	DCL-1000	-----	-----
AC300-T3-450G	1000A	2000A	DCL-1000	-----	-----
AC300-T3-500G	1000A	2000A	DCL-1200	-----	-----
AC300-T3-560G	-----	2000A	DCL-1200	-----	-----

Note: For DC reactor, input filter, output filter and other components specification details and circuit mode, please refer chapter 7 "peripheral equipments and options"

Control loop terminals

• Control loop terminals array

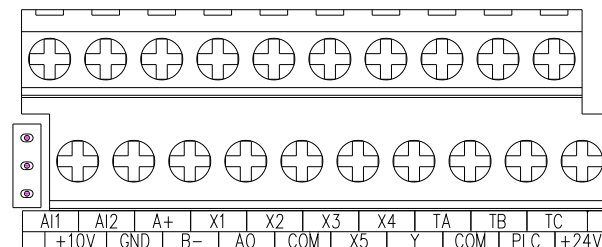

Table 3-7: AC300 series inverter control loop terminals array and definition

Sort	Terminal	Name	Function definition
Power supply	+10V-GND	External +10V power supply	Provide +10V power supply to the outside, the maximum output current: 50 mA is generally used as external potentiometer working power supply, potentiometer resistance range: 1KΩ ~ 5KΩ
	+24V-COM	External +24V power supply	Provides +24V power supply to the outside, generally used as digital input and output terminal working power supply and external sensor power supply Maximum output current: 100 mA
	PLC	External common terminal	Factory default connection with +24V When using X1-X5/PUL to drive the external signal, the PLC needs to be connected to the external power supply and disconnected from the +24V power supply (see "+24V", "PLC", "COM" connection diagram for details)
Analog input	A1-GND	Voltage or current type analog input	1. Input current range: DC 0V ~ 10V / 0mA ~ 20mA 2. Voltage type input impedance: 100KΩ 3. Current input impedance: 500Ω
	A12-GND	Voltage or current type analog input	1. Input current range: DC 0V ~ 10V / 0mA ~ 20mA 2. Voltage type input impedance: 100KΩ 3. Current input impedance: 500Ω
Digital input	X1-PLC	Multi-function contact input 1	Optocoupler isolation, compatible with

	X2-PLC	Multi-function contact input 2	bipolar inputs. 1. Input impedance: 4.4 KΩ 2. High-level input voltage range: 10 ~ 30V 3. Low-level input voltage range: 0 ~ 8V In addition to the features of X1 ~ X4, X5 can also be used as a high-speed pulse input channel (separate model). 1. Optocoupler isolation, compatible with bipolar input, maximum input frequency: 100KHZ 2. Input impedance: 1.5KΩ 3. Pulse input level range: 10 ~ 30V
	X3-PLC	Multi-function contact input 3	
	X4-PLC	Multi-function contact input 4	
	X5-PLC	Multi-function contact input 5	
	X5/PUL-PLC	Multi-function contact input 5 / high speed pulse input	
Analog output	AO1-GND	Analog output 1	1. Output voltage range: DC 0V ~ 10V 2. Output current range: DC 0mA ~ 20mA 3. Pulse output range: 0 ~ 50KHz
Digital output	Y-COM	Digital output 1	Optocoupler isolation, open collector output 1. Output voltage range: DC 0V ~ 30V 2. Output current range: DC 0mA ~ 50mA
Relay output	TA-TC	Normally open terminal	Contact drive capability: 240VAC, 3A 30VDC, 5A
	TB-TC	Normally closed terminal	
communication Terminal	A+	Communication terminal A+	RS485 communication interface. Select the RS485 communication access 120ohm terminal resistance by the toggle switch S4 (see Table 3-5 for details)
	B-	Communication terminal B-	

• Control loop terminal wiring specification

Table 3-8: Control loop terminal wiring specification

Terminal	Bolt specification (mm)	Fixed moment (N-m)	Cable specification (mm2)	Cable type
A+ B-	M2.5	0.4-0.6	0.75	Twisted-pair shielded cable
+10V GND A0 AI1 AI2	M2.5	0.4-0.6	0.75	Twisted-pair shielded cable
+24V COM Y TA TB TC PLC X1 X2 X3 X4 X5/PUL	M2.5	0.4-0.6	0.75	Shielded cable

Braking unit (braking resistance) connection

- Brake resistance wiring of machine with 22KW or less power:

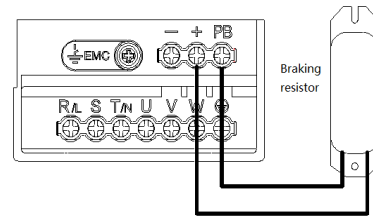

Fig 3-9: AC300 series frequency inverter brake resistance wiring of machine with 22KW or less power

- Brake resistance wiring of machine with 30KW or above

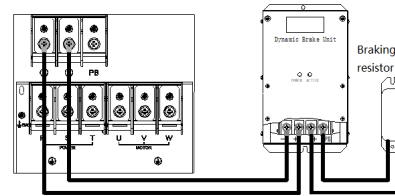

Fig 3-10: AC300 Series Frequency Inverter Brake resistance wiring of machine with 30KW or above

- Suggested braking resistance specification parameters

Braking resistance value and power in the chart are decided according to common inertia load and intermittent braking mode. While used in large inertia occasion or long time frequent brake occasion, please adjust resistance value and power according to the inverter specification and the rated parameter of braking unit. If any problem, please consult customer service department of Veichi Electric Com., Ltd.

Table 3-9: Suggested braking resistance specification parameters of AC300 series inverter

Three-phase 380V			
Motor power(kW)	Resistance value(Ω)	Resistance power(W)	Braking torque
0.75 kW	750Ω	150W	100%
1.5 kW	400Ω	300W	100%
2.2 kW	250Ω	400W	100%
4.0 kW	150Ω	500W	100%
5.5 Kw	100Ω	600W	100%
7.5 kW	75Ω	780W	100%
11 kW	50Ω	1,200W	100%
15 kW	40Ω	1,500W	100%
18.5 kW	32Ω	2,000W	100%

22 kW	32Ω	2,000W	100%
30 kW	24Ω	3,000W	100%
37 kW	20Ω	3,700W	100%
45 kW	16Ω	4,500W	100%
55 kW	13Ω	5,500W	100%
75 kW	9Ω	7,500W	100%
90 kW	6.8Ω	9,300W	100%
110 kW	6.2Ω	11,000W	100%
132 kW	4.7Ω	13,000W	100%
160 kW	3.9Ω	15,000W	100%
185 kW	3.3Ω	17,000W	100%
200 kW	3Ω	18,500W	100%
220 kW	2.7Ω	20,000W	100%
250 kW	2.4Ω	22,500W	100%
280 kW	2Ω	25,500W	100%
315 kW	1.8Ω	30,000W	100%
355 kW	1.5Ω	33,000W	100%
400 kW	1.2Ω	42,000W	100%
450 kW	1.2Ω	42,000W	100%
500 kW	1Ω	42,000W	100%
560 kW	1Ω	50,000W	100%
Single-phase 220V			
Motor power(kW)	Resistance value(Ω)	Resistance power(W)	Braking moment
0.4 kW	400Ω	100W	100%
0.75 kW	200Ω	120W	100%
1.5 kW	100Ω	300W	100%
2.2 kW	75Ω	300W	100%

• Build-in braking unit max braking performance

Braking unit of AC300 series product with low power can be selected according to the suggested braking resistance specification parameters in table 3-11. In large inertia or long time frequent brake occasion, the moment maybe should be increased. The max braking power is showed in the following table, the range of which can not be over in use. Otherwise the equipment maybe destroyed. If any problem, please consult Veichi Electric Com., Ltd customer service department.

Table 3-10:AC300 series inverter build-in braking unit max braking power

Three-phase380V			
Inverter model	Motor power	Max braking current	Min resistance
AC300-T3-R75G	0.75 kW	3.5A	200Ω
AC300-T3-1R5G	1.5 kW	3.5A	200Ω
AC300-T3-2R2G	2.2 kW	7A	100Ω
AC300-T3-004G	4 kW	10A	75Ω

AC300-T3-5R5G	5.5 kW	10A	75Ω
AC300-T3-7R5G	7.5 kW	14A	50Ω
AC300-T3-011G	11 kW	17A	40Ω
AC300-T3-015G	15 kW	23A	30Ω
AC300-T3-018G	18.5 kW	28A	25Ω
AC300-T3-022G	22 kW	28A	25Ω

Three / Single-phase 220V			
Inverter model	Motor power	Max braking current	Min resistance
AC300-T/S2-R40G	0.4 kW	3.8A	100Ω
AC300-T/S2-R75G	0.75 kW	3.8A	100Ω
AC300-T/S2-1R5G	1.5 kW	6.5A	60Ω
AC300-T/S2-2R2G	2.2 kW	10.5A	40Ω

Standby control system

Frequency inverter is composed of semiconductor, passive electronic component and driving part. All of them have useful time, which means these parts may happen characteristic change or out of use in normal working environment. And it will cause product fault. To avoid production stop led by the fault, we suggest preparing standby control system when using the inverter.

Chart 3-11 is a standby control system for manual switch to power supply driving motor at inverter fault. Standby control systems such as power supply Y/Δ step-down start way driving motor, power supply self-coupling reduction voltage start mode driving motor, power supply soft start mode driving motor or standby inverter system can be chose to use according the actual requirement and environment.

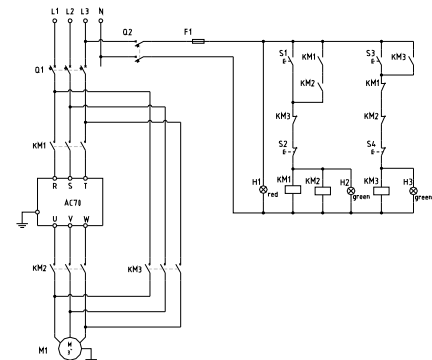





Chart 3-11: Standby control system of power supply directly driving mode

Chapter4 Basic Operation and Trial Run

4.1 Safety Precautions

	<ul style="list-style-type: none"> No wiring while power supply is connected. Otherwise there is danger of electric shock.
	<ul style="list-style-type: none"> No operation while the cover is open. Otherwise, there is danger of electric shock. Please ensure reliable earth. Otherwise, there is danger of electric shock and fire. Before wiring please cut power supply of all related equipments and ensure main DC voltage in safe range. And please do operation after 5 mins. Only professional trained person is allowed to operate this product. Please do not dismantle the inverter cover while it is electrified. Otherwise, there is danger of electric shock. Please do not touch the printed circuit board of the inverter while it is electrified. Otherwise, there is danger of electric shock. Please ensure reliable mains cable connection. If the mains cable is loose, there is danger of fire caused by joint overheat. Before electrifying, please check the power voltage again. Wrong power voltage can cause fault or damage the inverter, even cause fire. Please do not install inverter on flammable material or attach flammable material to the inverter. Before electrifying, please clear the surroundings.
	<ul style="list-style-type: none"> While operation, please follow the ESD regulations. Otherwise, the inverter maybe damaged. Please don't cut the power directly while the inverter drives the motor running. The power can't be cut until the motor totally stop. Otherwise, the inverter maybe damaged. Please don't cut or connect motor while the inverter drives the motor running. The motor can't be cut or connect until the inverter output is 0. Otherwise, the inverter maybe damaged. Control cable should be twisted-pair shielded cable. The barrier should be connected to the inverter earth terminal reliably to prevent the inverter from abnormal working. Unprofessional person can not operate, install, wiring, debug and maintain. Change, dismantle or maintain without permission may cause inverter damage. This case is not in our quality assurance range.





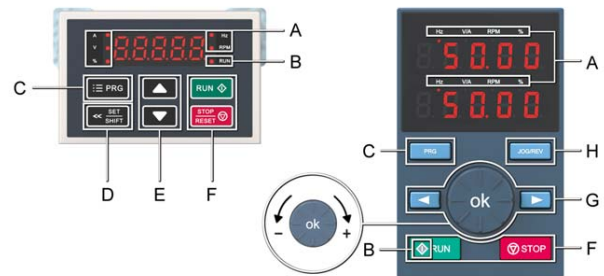

4.2 Keyboard layout and functions specification

Keyboard name

Integrated keyboard (37KW and below) Double-line keyboard (37KW or more machine)



Key function

	Integrated keyboard	Double-line keyboard	Function
A	Unit indicator		Hz: Frequency A: Current V: Voltage V/A: Voltage or current RPM: Speed %: Percentage
B	Status Indicator		On: Forward running status Blinking: Reverse running status Off: Stop status
C	Menu 	Menu 	Enter the function menu interface during standby or running; press this button to exit the modification when the parameter is modified; press the button (1 second) during standby or running to enter the status interface directly.
D	Set/Shift 		Set function: After modifying the value, press this key to confirm the modified value. Shift function: long press this button (1 second) to move the operation bit, long press is not loose, then cyclic shift
E	Up, Down 		The up key increases the operation value and the down key decreases the operation value.
F	Run 	Run 	When the run/stop is controlled by the keyboard, press this button to turn the inverter forward. The status indicator is always on during forward run, and the status indicator is flashing during reverse run.

			When the command given channel is keyboard control, press this key to stop the inverter; the parameter [F04.08] can be used to define whether other command channels are valid; the inverter resets when pressing the key in fault status.
G			Digital potentiometer: clockwise to increase the operating value, counterclockwise to decrease the operating value Set key: After modifying the value, press this key to confirm the modified value.
			Move left and right operation bits
H			Select the function of the key by parameter [F04.07], 0: reverse 1: jog

● Number word comparison table

Table 4-1: Digital Text Comparison Table

Word	LED Display	Word	LED Display	Word	LED Display
0	0	C	C	O	0
1	1	D	D	P	8
2	2	E	E	Q	9
3	3	F	F	R	8
4	4	G	0	S	9
5	5	H	8	T	8
6	6	I	8	U	0
7	7	J	0	V	0
8	8	K	8	W	00
9	9	L	8	X	No Display
A	8	M	00	Y	4
B	6	N	8	Z	No Display

Chapter 5 Fault Diagnoses and Processing

This chapter explains the display content and processing of the inverter fault, alarm and operation fault. It also simply explains the bad situation caused by inverter or motor fault and how to solve it. For the adjustment guide in trial run, please refer this chapter too.

5.1 Fault Types

Type	Inverter action while fault happens
External fault	In certain application occasions, external related equipments fault signals are considered in the inverter control system as usage of monitoring, protection or switch control. At this time, if one multi function terminal is defied as "external fault", the inverter stops output alarm signal.

5.2 Fault Information and Details

Chart 5-1: Fault information and details

Keyboard display	Communication code	Fault type	Possible causes	Treatment
	64	Too low voltage while stop	<ul style="list-style-type: none"> Power supply is too low Voltage detection circuit is abnormal 	<ul style="list-style-type: none"> Check input power,clear fault. Seek support from factory.
	10	Too low voltage in run	<ul style="list-style-type: none"> Power supply is too low Power capacitance is too small, or there is big impact current in the power grid. Inner DC main contactor is not connect well 	<ul style="list-style-type: none"> Check input power,clear fault. Improve power supply. Seek support from factory.
	7	Accel. over-voltage	<ul style="list-style-type: none"> Power voltage fluctuation over limit. Start when motor is running . 	<ul style="list-style-type: none"> Detect power voltage and clear fault. Restart motor until it completely stop.Set E-30 as 1or2.

E.oU2	8	Decel. over-voltage	<ul style="list-style-type: none"> Deceleration time is too short. Load potential energy or inertia is too large. Power voltage fluctuation over limit. 	<ul style="list-style-type: none"> Prolong Deceleration time. Reduce load inertia or improve inverter capacitance or add braking unit. Detect power voltage and clear fault.
E.oU3	9	Constant speed over-voltage	<ul style="list-style-type: none"> Power voltage fluctuation over limit. 	<ul style="list-style-type: none"> Detect power voltage and clear fault. Install input reactor.

E.oU4	28	Over-voltage while stop	<ul style="list-style-type: none"> Power voltage fluctuation over limit. 	<ul style="list-style-type: none"> Check input power, clear fault. Seek support from factory.
E.oC1	4	Accel. over-current	<ul style="list-style-type: none"> Acceleration time is too short. Start running motor. V/F curve setting is not suitable. Or torque boost too high. Inverter capacitance is too small. 	<ul style="list-style-type: none"> Prolong acc time. Restart motor until it totally stop. Set E-30 as 1or2. Reset V/F curve or torque boost value. Select inverter with right capacitance.
E.oC2	5	Decel. over-current	<ul style="list-style-type: none"> Deceleration time is too short. Load potential energy or inertia is too large. Power voltage fluctuation over limit. 	<ul style="list-style-type: none"> Prolong Deceleration time. Connect external braking resistance or braking unit. Select inverter with right capacitance.
E.oC3	6	Constant speed over-current	<ul style="list-style-type: none"> Sudden load change. Power grid voltage is too low. 	<ul style="list-style-type: none"> Check load change and clear it. Check input power, clear fault.
E.oL1	11	Motor over-load	<ul style="list-style-type: none"> V/F curve setting is not suitable. Or torque boost too high. Power grid voltage is too low. incorrect overload protection setting. Locked-rotor run or too heavy load. Universal motor long time low speed run. 	<ul style="list-style-type: none"> Reset V/F curve or torque boost value. Check input power, clear fault. Unreasonable H-56 setting. Adjust load or select inverter with right capacitance. If need long time low speed run, please choose special motor for inverter.
E.oL2	12	Inverter over-load	<ul style="list-style-type: none"> Load is too heavy. Acceleration time is too short. Start running motor. V/F curve setting is not 	<ul style="list-style-type: none"> Select inverter with right capacitance. Prolong acceleration time Restart motor until it totally

			<ul style="list-style-type: none"> suitable. Or torque boost too high. 	<ul style="list-style-type: none"> stop. Set E-30 as 1or2. Reset V/F curve or torque boost value.
E.SC	1/2/3	System abnormality	<ul style="list-style-type: none"> Acceleration time is too short. Short circuit between inverter output phases or earth. Module is damaged. Electromagnetic disturb. 	<ul style="list-style-type: none"> Prolong acceleration time. Check periphery equipments and restart after fault cleared. Seek support from factory. Check system wiring, earth, shield and deal as required.
E.oH1	16	Inverter over-heat	<ul style="list-style-type: none"> Temperature is too high. Air channel is blocked. Fan connection parts is loose. Fan is damaged. Temperature detection circuit fault 	<ul style="list-style-type: none"> Make the environment meeting the requirement. Clear the air channel. Check and re-connect the wire Change the same new fan. Seek support from factory.
E.oH2	17	Rectifier bridge over-heat	<ul style="list-style-type: none"> Temperature detection circuit fault 	<ul style="list-style-type: none"> Check motor connection wire. Check motor stop totally. Change inverter model. Reset parameter according to nameplate.
EFE1	20	Motor detection fault	<ul style="list-style-type: none"> Detection overtime Perform static detection while motor is running. Capacitance difference is too big between motor and inverter. Motor parameter setting mistake. 	<ul style="list-style-type: none"> Check motor connection wire. Check after motor stop totally. Change inverter model. Reset parameter according to nameplate.
EEEE REEP	21/69	Memory fault	<ul style="list-style-type: none"> Electromagnetic disturb in memory period. EEPROM damage. 	<ul style="list-style-type: none"> re-input and save. Seek support from factory.
LIFE	30	Reserved		<ul style="list-style-type: none"> Seek support from factory.
E.LLF R.LLF	13 /65	Input phase missing	<ul style="list-style-type: none"> 3 input phase missing 	<ul style="list-style-type: none"> Check 3phase input power and phase. Check 3phase input power wiring.
E.oLF	14	Output phase missing	<ul style="list-style-type: none"> 3 phase output of inverter missing connection with motor 	<ul style="list-style-type: none"> Check wire between inverter and motor, earth and motor insulation.
EGnd	-	Output Ground	<ul style="list-style-type: none"> The output side of the inverter is shorted to ground. 	<ul style="list-style-type: none"> Check wiring and motor insulation.
E.HAL	19	Current detection fault	<ul style="list-style-type: none"> Detect circuit fault. Phase imbalance 	<ul style="list-style-type: none"> Seek for technique support. Check motor and wiring.
E.EF	17	Inverter external fault	<ul style="list-style-type: none"> Peripheral equipment fault protection. 	<ul style="list-style-type: none"> Check peripheral equipment.
E.PPn	E.PAn	Keyboard	<ul style="list-style-type: none"> Keyboard wire fault. 	<ul style="list-style-type: none"> Check keyboard wire

		connect fault	<ul style="list-style-type: none"> Keyboard component damage. 	<ul style="list-style-type: none"> Seek support from factory.
E.CE	18	RS485 communication fault	<ul style="list-style-type: none"> Baud rate not right. Communication connection not right. Communication format not right. 	<ul style="list-style-type: none"> Set right Baud rate Check communication wiring Check Communication format
E.CPE	E.CPE	Parameter copy fault	<ul style="list-style-type: none"> Parameter copy communication is fault. Copy keyboard is not match the inverter. 	<ul style="list-style-type: none"> Check wire. Select the specified external keyboard model.
E.ECF	-	Expansion card connection is abnormal	<ul style="list-style-type: none"> The expansion card communicates with the inverter for timeout; The expansion card does not match the drive. 	<ul style="list-style-type: none"> Check the connector and re-plug the cable; Use the expansion card of the specified model.
E.PG	27	PG card connection is abnormal	<ul style="list-style-type: none"> PG card and inverter connection failure 	<ul style="list-style-type: none"> Check connection
E.PId R.PId	29 /66	PID feedback fault	<ul style="list-style-type: none"> PID feedback disconnection alarm upper limit is set improperly PID feedback disconnection alarm lower limit is set improperly Lose PID feedback wiring Feedback sensor failure Feedback input loop fault 	<ul style="list-style-type: none"> Confirm the sensor status and replace the sensor if it is damaged. Correct wiring Confirm the set values of F11.27 and F11.28
E.IRE	31	Initial position angle learning failed	<ul style="list-style-type: none"> Check motor parameters 	<ul style="list-style-type: none"> Check the motor parameters; Learn after the motor is stationary; Seek technical support from manufacturers.
E.dEF R.dEF	32 /70	Speed deviation is too large	<ul style="list-style-type: none"> Checkout time or check level setting is unreasonable Motor parameter is abnormal 	<ul style="list-style-type: none"> Check the motor parameters and re-learn again; Check the F10.24/F10.25 parameter settings; Seek technical support from manufacturers.
E.SPd R.SPd	33 /71	Speed protection	<ul style="list-style-type: none"> FA.27/FA.28 parameter setting is abnormal Motor parameter is abnormal 	<ul style="list-style-type: none"> Check the motor parameters and re-learn again; Check the F10.27/F10.28

			<ul style="list-style-type: none"> Check the F6 group vector control parameters 	<ul style="list-style-type: none"> parameter settings;
E.Ld1 R.Ld1	34 /67	Load protection 1	<ul style="list-style-type: none"> The checkout time or check level setting is unreasonable 	<ul style="list-style-type: none"> Check the F10.18/F10.19 parameter settings;
E.Ld2 R.Ld2	35 /68	Load protection 2	<ul style="list-style-type: none"> The checkout time or check level setting is unreasonable 	<ul style="list-style-type: none"> Check the F10.20/F10.21 parameter settings;
E.CPU	36	CPU time out	<ul style="list-style-type: none"> CPU timing timeout 	<ul style="list-style-type: none"> Seek technical support from manufacturers.
R.O72	72	GPS lock machine	<ul style="list-style-type: none"> GPS timing timeout 	<ul style="list-style-type: none"> Seek technical support from manufacturers.
R.O73	73	GPS disconnection	<ul style="list-style-type: none"> GPS communication disconnection 	<ul style="list-style-type: none"> Whether the GPS expansion card is connected properly; GPS communication card is arrears; Seek technical support from manufacturers.
E.SG	40	Fan short circuit	<ul style="list-style-type: none"> Fan short circuit 	<ul style="list-style-type: none"> Check if the fan is smooth
E.FSG	39	Motor short to ground	<ul style="list-style-type: none"> Motor short circuit to ground 	<ul style="list-style-type: none"> Check if the motor is shorted to ground

5.3 Fault Diagnoses Process

System fault diagnoses process

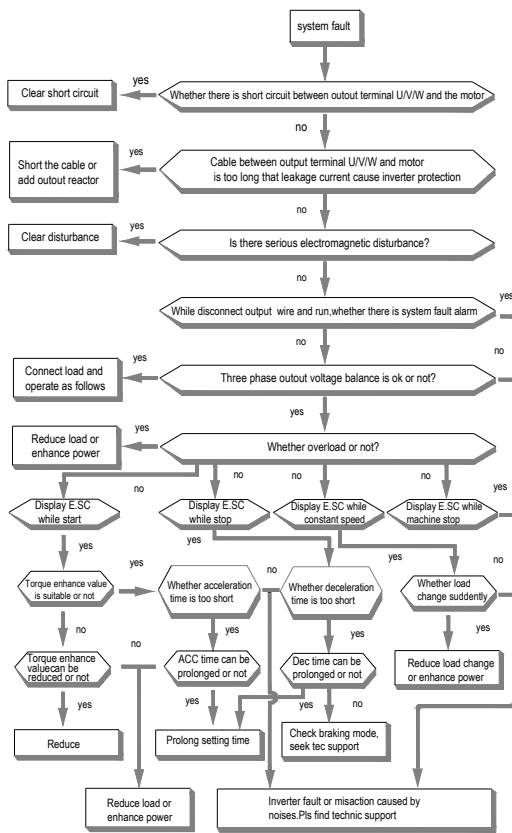

Over-current diagnoses process

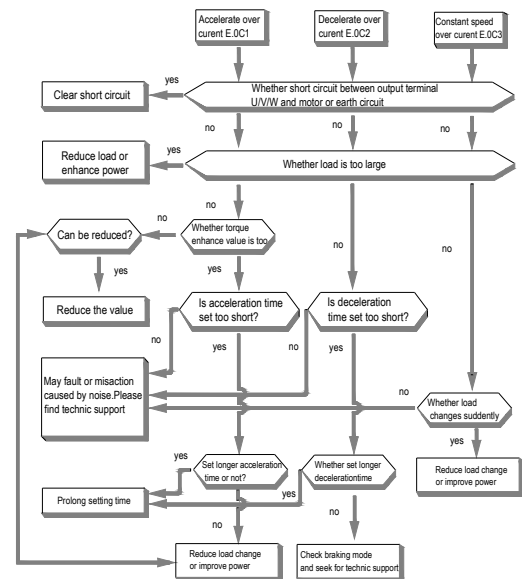

Over-voltage diagnoses process

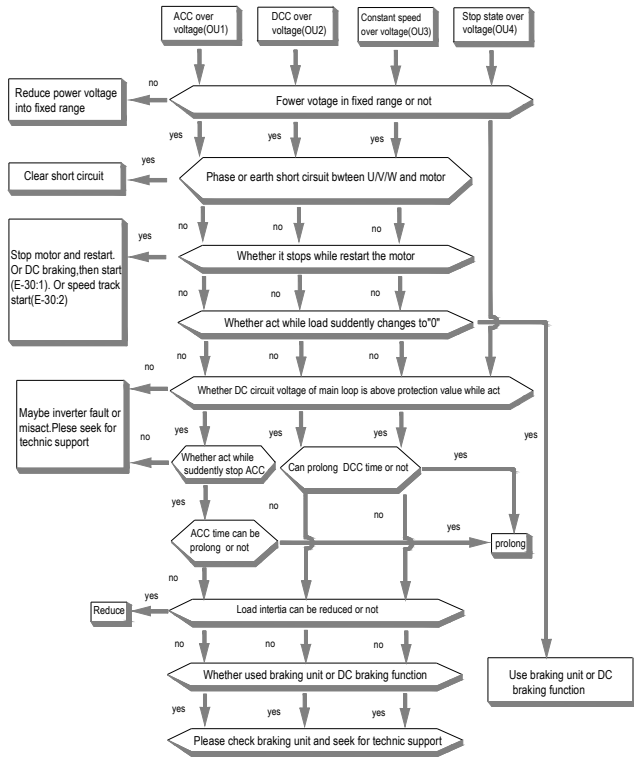

Low-voltage supply

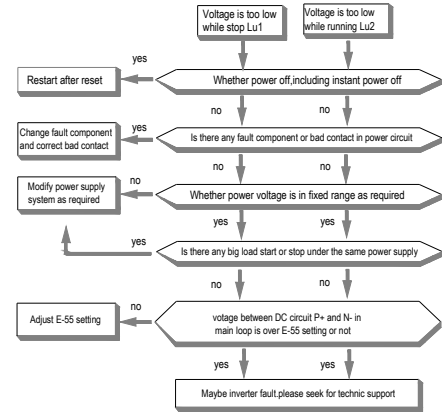

Inner inverter over-heat

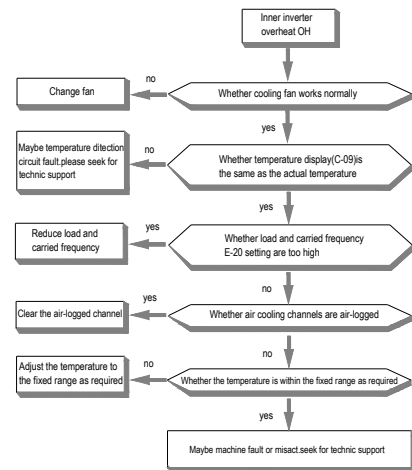

Over-load

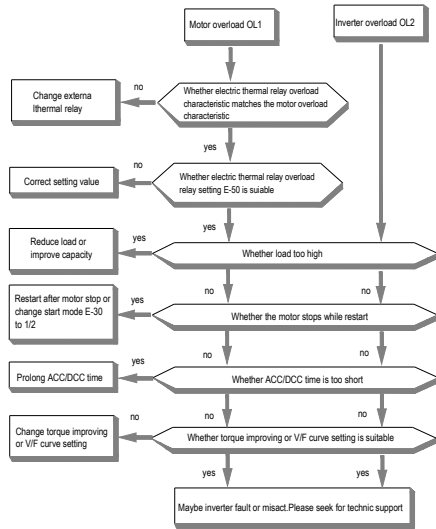

No display

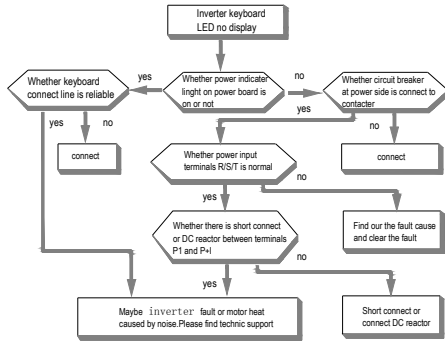

Motor heat

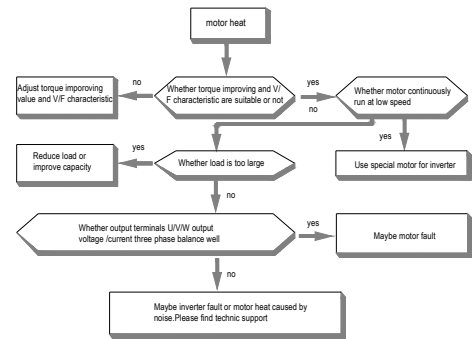

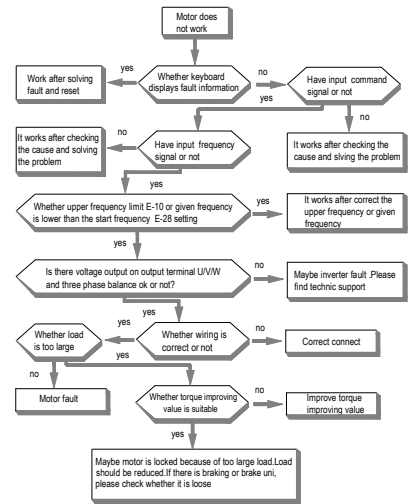

Motor does not rotate



Chapter 6 Periodic Overhaul and Maintenance

6.1 Safety Precautions

This chapter explains the safety rules in overhaul and maintenance.

 DANGER	<ul style="list-style-type: none"> No operation under power connected state. Otherwise, there is danger of electric shock even death. Before operation, please cut all related equipments power, ensure that the main circuit DC current has dropped to safe range. And please operate after 5 mins.
 WARNING	<ul style="list-style-type: none"> No operation while cover/panel is dismantled. Otherwise there is danger of electric shock even death. Do not dismantle the cover or PCB under power connected state. Otherwise there is danger of electric shock death. Only professional person can maintain or change fittings. Otherwise, there is danger. Do not wear loose clothes when install, debug, maintain. Related protective tools and safeguard should be adopted. Tighten screw according to named torque. If main circuit wire connection is loose, there is danger of overheat fire. Machine and motor earth must be reliable. Otherwise, there is danger of electric shock if touch the cover.
 IMPORTANT	<ul style="list-style-type: none"> While operation, please follow the ESD regulations. Otherwise, the inverter maybe damaged. Do not change the circuit or structure of the inverter. Otherwise, the inverter maybe damaged. Please confirm the rotate direction while no-load. Wrong direction can bring body injury or huge wealth loss. Do not use damaged machine. Otherwise, there is danger of accident.

6.2 Overhaul

Frequency inverter is composed by semi-conductive components, passive electronic component and motive component. All of these components have useful life. Even under normal working environment, some of the components can not work after the life time. To avoid malfunction, daily checking, periodic overhaul, component changing and other maintenance should be carried out to prevent. We suggest one overhaul every 3-4 months after installation. The overhaul period should be shortened while under cases as below:

- High temperature, high altitude;
- Start and stop frequently;
- AC power supply or load fluctuate badly;
- With serious vibration or impact;
- With dust, metal dust, salt, vitriol, chlorine;

- Bad storage environment;
- Daily checking**

To avoid machine damage and to prolong life time, please check the following items everyday.

Items	Checking content	Treatment
Power supply	Check if power supply meets the requirement and whether there is lack-phase.	Treat it as nameplate explains.
Surroundings	Check whether it meets the table3-1 requirement.	Make sure the problem and solve it.
Cooling system	Check whether the inverter or the motor heat or change color abnormally and cooling fan working state.	Check whether it overload. Tighten screw. Check whether cooling fan is dirty or stall rotate.
Motor	Check if there is abnormal vibration or noise.	Tighten machine and electric connection and lubricate the machine components.
Load	Check whether output current is over the rated value of the motor or the inverter and has lasted for a period.	Make sure whether it overload and whether the machine model is right.

Cautions:

- No operation under power connected state. Otherwise, there is danger of electric shock death. Before operating, please cut all related equipments power, ensure that the main circuit DC current has dropped to safe range. And please operate after 5 mins.**

Periodic overhaul

Under normal state, one overhaul every 3 or 4 months is ok. Please confirm the actual overhaul period according to the machine use condition and work circumstance while using the machine.

Main circuit:

Items	Checking content	Treatment
Whole	<ul style="list-style-type: none"> Check insulated resistance; Check circumstance. 	<ul style="list-style-type: none"> Tighten and change bad component; Clear and improve circumstance.
Electric connection	<ul style="list-style-type: none"> Check whether the wire and connector color changes, whether there is disrepair, crack color change or aging in insulated layer. Check whether the connect terminals are frayed, damaged or loose. Earth checking. 	<ul style="list-style-type: none"> Change bad wire. Fasten terminals and change bad terminals. Measure earth resistance and fasten earth terminals.
Mechanical connection	<ul style="list-style-type: none"> Check if there is abnormal vibration or noise or something is loose. 	<ul style="list-style-type: none"> Tighten, lubricate and change the bad components.

semi-conductive component	<ul style="list-style-type: none"> Check whether there is dust or rubbish. If there is obvious out change 	<ul style="list-style-type: none"> Clean operation environment Change damaged component
Electrolytic capacitor	<ul style="list-style-type: none"> Whether there is liquid leak, color change or crack. Whether the safety valve outcrop, inflation, creak or liquid leak. 	<ul style="list-style-type: none"> Change damaged component

Peripheral equipment	<ul style="list-style-type: none"> Peripheral equipment outlook and insulation checking. 	<ul style="list-style-type: none"> Clear and change damaged component.
PCB	<ul style="list-style-type: none"> Peculiar smell color change, bad rust and connector checking. 	<ul style="list-style-type: none"> Fasten connector Clear PCB Change damaged PCB
Cooling system	<ul style="list-style-type: none"> Check whether the fan is damaged or blocked up. Whether rubbish and dust is stuck to the heatsink. Is air inlet/outlet blocked? Or is there something sticking to the inlet/outlet. 	<ul style="list-style-type: none"> Clean operation environment Change damaged component
Keyboard	<ul style="list-style-type: none"> Whether it is damaged. Check whether display is complete. 	<ul style="list-style-type: none"> Change damaged component
Motor	<ul style="list-style-type: none"> Check if there is abnormal vibration or noise. 	<ul style="list-style-type: none"> Tighten machine and electric connection and lubricate the machine components.

Cautions:

- No operation under power connected state. Otherwise, there is danger of electric shock death. Before operating, please cut all related equipments power, ensure that the main circuit DC current has dropped to safe range. And please operate after 5 mins.

6.3 Maintenance

All equipments and components have useful life. Right maintenance can prolong the lifetime. But it can not avoid damage. Please change the components before their lifetime over.

Component	Useful lifetime
Fan	2-3year
Electrolytic capacitor	4-5 year
PCB	8~10 year

• Fan

While changing fan, please use original fan. You can contact Veichi company or the dealer. There are inverter

models with many fans in one machine. To prolong these machines' lifetime, you had better to change all fans while changing the cooling fan.

Cautions:

- No operation under power connected state. Otherwise, there is danger of electric shock death. Before operating, please cut all related equipments power, ensure that the main circuit DC current has dropped to safe range. And please operate after 5 mins.
- While the inverter is working, the heatsink temperature will be higher as the consumption. To prevent from scald, please do not touch the heatsink and do not change the fan until the temperature being safe.
- To ensure the best performance of the inverter, please use the original fan.



• Other components

The replacement of the other components has strict requirements on maintenance technic and product familiarity. And they can not be used without strict detection after replacement. So we suggest the user not to replace the other inner components. If they need to change indeed, please contact to the dealer or the sales department of Veichi electric company.

Chapter 7 Peripheral Equipments and Options

7.1 Safety Precautions













User must obey to the following safety rules and related requirements while using the peripheral equipments and selecting components.

	<ul style="list-style-type: none"> No operation under power connected state. Otherwise, there is danger of electric shock. Before operation, please cut all related equipments power, ensure that the main circuit DC current has dropped to safe range. And please operate after 5 mins.
	<ul style="list-style-type: none"> No operation while cover/panel is dismantled. Otherwise, there is danger of electric shock. Do not dismantle the cover or PCB under power connected state. Otherwise, there is danger of electric shock. Only professional person can install, debug or maintain the peripheral equipments and options. Otherwise, there is danger. Do not wear loose clothes when install, debug, maintain. Rated protective tools and safeguard should be adopted. Do not change wire, dismantle jumping wire, optional card, or change cooling fan while the inverter is running. Otherwise, there is danger of electric shock. Tighten screw according to named torque. If main circuit wire connection is loose, there is danger of overheat fire. Earth of the peripheral equipments and options must be reliable to prevent human body injury.
	<ul style="list-style-type: none"> While operation, please follow the ESD regulations. Otherwise, the inverter maybe damaged. Do not cut the power supply while the inverter is outputting voltage. Otherwise, the inverter maybe damaged.

7.2 Peripheral Equipments

Normal peripheral equipments are showed as follows. To order the peripheral equipments, please consult our dealer or sales department.

Peripheral equipment	Functions
	Breaker Protect power system and prevent malfunction impact other equipments working when short-circuit happens. And over-load protection.

	Leakage current breaker	Earth protection prevent electric shock(suggest to use the type which can prevent high-frequency leakage current)
	Electromagnetic contactor	Separate power and inverter indeed and realize basic relay control.
	AC input reactor	Improve power side factor and isolate the noise disturbance to the frequency inverter from the power side.
	DC reactor	Restrain ultra harmonics and improve power factor.
	Input side noise filter	Reduce frequency inverter disturbance to the power and reduce the power grid disturbance.
	Braking resistor	Passive energy consume unit of electric braking.
	Consumption braking unit	Electric braking control unit, controlling the braking resistance consume the regenerated electric power of the motor efficiently.
	Output side noise filter	Reduce the output side wire electromagnetic disturbance.
	Standby system	Standby system for inverter malfunction.
	Heat relay	Protect the motor while over load.
	0-phase reactor	Reduce electromagnetic disturbance of the frequency inverter (suitable for input/output side).
	Main loop surge absorption unit	Restrain surge voltage while main loop switch components act.
	Winding surge absorption unit	Restrain surge voltage when the AC contactor acts.

7.3 The use of peripheral equipments

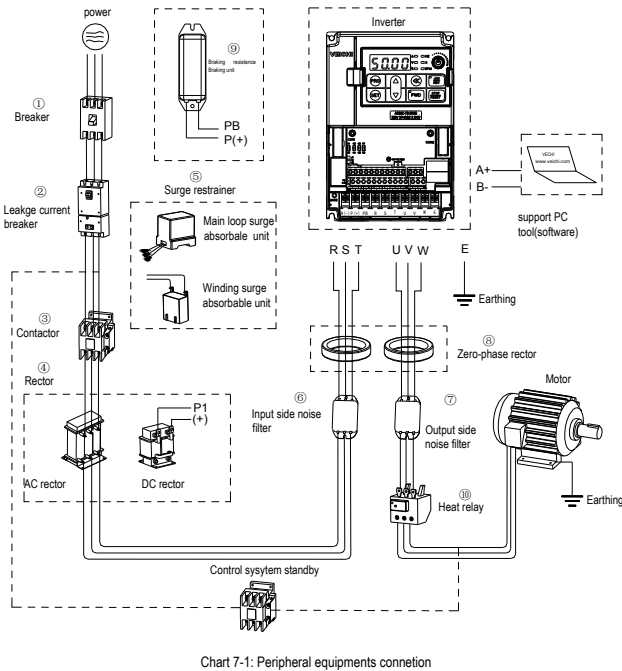

Chart 7-1: Peripheral equipments connection

Note:

● Wiring breaker

To ensure wiring safe, protect power system and prevent malfunction impact other equipment working when short-circuit happens, and protect while over-load, please do use wiring breaker between power supply and main loop power input terminals R,S,T.

While choosing the breaker, the capacitance should be about 1.5-2 times of the rated output current of the frequency inverter. Please compare the time characteristic of breaker and the characteristic of the inverter protection (150% of the rated output current, one minute). Make sure there will be no skip.

Before main loop wiring, make sure to cut the breaker and electromagnetic contactor. Otherwise, there is danger of electric shock.

● Leakage current breaker

The frequency inverter outputs peak voltage high-speed switch square wave, so there is high frequency leakage current. For earth protection to prevent electric shock and leakage current fire, please install leakage current breaker. Usually, one frequency inverter will bring 100mA leakage current (while the power cable length is 1m). If the length prolongs 1m, there will be 5mA more leakage current. So please use leakage current breaker special for high frequency leakage at the power input side of the frequency inverter. The factors which impact leakage current are as follows:

- Capacitance of inverter;
- Carrier frequency;
- Motor cable type and wire length;
- EMI/RFI filter.

To protect human body and inverter, please choose leakage current breaker which can use AC/DC power and can reply high frequency leakage current. There should be one leakage current breaker with more than 200mA sensitive current for every frequency inverter. If the frequency inverter outputs different wave, the high frequency leakage current will be higher, what will make the breaker malfunction. At this case, please take following treatments:

- Improve the sensitive current of the leakage current breaker;
- Reduce the carrier frequency of the inverter.

● Electromagnetic contactor

Electromagnetic contactor is a peripheral equipment what is set to separate power and inverter connection. While inverter protective function is acting or carrying out emergency stop operation, the main loop power can be cut by peripheral equipment. Please do not connect the electromagnetic switch or electromagnetic contactor to output circuit. Otherwise, the inverter maybe damaged. While the power recovers after instant stop, if it needs to prevent the inverter to auto-restart, please install electromagnetic contactor for control at the input side.

● AC input reactor and DC reactor

To restrain current sharp change and high hypo harmonic current, it needs to use AC input reactor and DC reactor. It can also improve power factor at the input side. In the following cases, AC input reactor or DC reactor must be used (use both will bring better effect).

- Need to restrain ultra harmonics current and improve power side factor;
- Need to switch input phase capacitance;
- When frequency inverter is connected to large capacitance power transformer (600kVA above);
- Silicon-controlled converters such as DC motor driver are connected to the same power system.

If user has higher requirement on other harmonic restraint, please connect the external DC reactor .Before connecting the external DC reactor, make sure to dismantle the short connector between the terminals P1 and (+).

● Surge restrainer

Surge restrainer is divided to winding surge restrainer and main loop surge restrainer according to the use position. Pts choose the right one which is suitable for the occasion. The aim of surge restrainer installation is restraining the surge voltage brought by switch components such as inductive load which is surrounding the frequency inverter (electromagnetic contactor, electromagnetic relay, electromagnetic valve, electromagnetic winding, electromagnetic detent). Do not connect the surge restrainer to the output side of the frequency inverter. Otherwise, the frequency inverter will be damaged.

● Input side noise filter

Rectifier bridge of the inverter is uncontrolled rectifier. And input current is discontinuous impulse current. So the harmonic current noise signal, what flows to power wire from the inverter inner, maybe bring bad impact on the surrounding machines (radio, phone, noncontact switch, sensor). This time, we suggest to instal input side noise filter to lighten the noise into the power wire. Besides, it can also reduce noise from the power wire into the frequency inverter.

Please use the special noise filter for the frequency inverter and the connection wire between the filter

and the inverter should be as short as possible.

- **Output side noise filter**

The frequency inverter outputs square wave with high-speed peak value voltage switch. So there is high-speed dv/dt converter on the output cables that will produce a large number of radio disturbance and inductive signal. By installation noise filter at the output side, the impact can be relieved. Please do not install the into phase capacitance and the noise filter to the output circuit. Otherwise, there is danger of damage to the frequency inverter.

- **phase reactor**

0-phase reactor is used for reducing the electromagnetic interference of the frequency inverter, which is suitable for the input side and output side. It equals to a three-phase common mode inductance. In actual use, according to the actual magnetic core size and cable specification, it is better to make sure 3-5 circles winding ratio to bring the best performance.

- **Braking reactor or braking unit**

Renewable electricity consumption unit, please see the sixth part of the chapter three "electric installation".

- **Heat relay**

Please install the heat relay at the output side of the frequency inverter. When the motor enters into overload state, it will cut the power source to protect the motor. While using one frequency inverter to drive one motor, it is unnecessary to install heat relay. The motor overload protection current [F10.16] of the frequency will work. While using one frequency inverter to drive multiple motors or the motor is drove directly by the power grid, please install heat relay between the inverter and the motor. While installing the heat relay, please design to cut the sequence control circuit of the MC at the main loop input side by the connection spot of the relay or design to input the heat relay action into the frequency inverter as the exterior malfunction. And please pay attention to the following tips to avoid heat relay malfunction and motor overheating at low speed.

Run at low speed

One frequency inverter run multiple motors

Motor cable is very long

Detect malfunction mistakenly for carrier frequency is too higher.

- **Low speed and heat relay**

In normal case, the heat relay is suitable for the universal motor. While using the frequency inverter to run the universal motor (standard motor), the motor current is 5-10% higher, comparing with the commercial power supply. Besides, at low speed, even in the motor rated current range, the cooling capability of the fan drove by the motor axis will reduce, which will bring motor overheat. So please set the motor overheat protection current [F10.16] in the frequency inverter to be valid.

- **Motor cable is longer**

While the motor cable is longer and the carrier frequency is higher, impacted by the leakage current, the heat relay maybe malfunction. To avoid it, please reduce the carrier frequency or set higher detection value of the heat relay. Before enhance the detection value, do confirm whether there is other cause for the motor overheat. Otherwise, there is danger.

Chapter 8 Function Parameter Specifications

8.1 Basic Parameters

F00.00	Motor control mode	Setting range: 0~8	Default: 0
--------	--------------------	--------------------	------------

Asynchronous motor control mode (AM) :

0: V/F control

When the frequency (F) is adjustable, the ratio of the control frequency to the voltage (V) is kept constant.

The control mode is used for speed control without requiring fast response and high precision.

3: High-performance VC without PG

There is without speed sensor vector control, which is used for speed control that requires high precision.

Under this mode control, the torque can respond fastly even without using the speed feedback signal of the motor, and a large torque can be obtained when the low speed motor is running. For better control, please make motor parameter auto-tuning.

4: High-performance VC with PG

There is vector control with speed sensor, which is used for speed control of fast torque response and high performance torque control.

Mainly used for high-precision speed control, torque control, simple servo control and other places where strict control performance is required. For better control, please make motor parameter auto-tuning. In order to receive the speed feedback signal of the motor, you need to use the PG option card.

In order to receive the speed feedback signal of the motor, you need to use the PG optional card.

Synchronous motor control mode (PM) :

6: High-performance VC without PG

The permanent magnet synchronous motor has no PG feedback vector control. Through the software algorithm, the complete model and observer of the permanent magnet synchronous motor are built in, and the magnetic pole position and speed of the motor are observed in real time.

The mode requires complete no-load identification of the motor, which is suitable for occasions where the acceleration/deceleration time is high and the load is an impact load.

7: High-performance VC with PG

The permanent magnet synchronous motor has speed sensor control, featuring dynamic response and high control performance. It can perform torque control and weak magnetic high-speed operation, and can be used for high-power servo control.

1, 2, 5: Reserved

Notes:

1. PG refers to the speed encoder, used as PG vector control, generally with photoelectric encoder or rotary transformer, need to select the corresponding PG card according to PG type and parameters, see function code [F05.30];
2. When selecting the vector control mode, before the first run, first input the motor parameters correctly and perform automatic motor parameter tuning to obtain the correct motor parameters. For details, please refer to the detailed description of the "F05" motor parameter group.
3. The parameters of the vector control parameter group should be correctly set to ensure good steady state and dynamic control performance. For the parameter setting and adjustment of the vector control parameter group, please refer to the detailed description of the "F06" parameter group.
4. When selecting the vector control mode, it should be noted that the inverter can only drive one motor at the same time; and the inverter capacity and the motor capacity level cannot be too different, the inverter can be two or smaller than the motor power level. Failure to do so may result in reduced control performance or the drive system may not function properly.

F00.01	Reserved		
F00.02	Run command channel	Setting range: 0~3	Default: 0

Uses for selecting inverter running, stop and running direction command input channel.

0: keypad control

Running and stop of inverter control by forward running key PRG , stop key STOP/RESET of operator keypad. When [F04.07] parameter set to 1, REV/JOG is defined for JOG running.

1: terminal control

Running, stop and rotation direction of inverter control by terminal . See [F02.00~F02.09] for details. See [F02.23] for the terminal operation control mode and [F02.24] for the terminal startup protection.

2: RS485 communications port control

The running command is given by the host computer through communication. For communication parameter settings, please refer to the F13 communication control parameter group.

When the peer-to-peer broadcast communication, the slave selects the run command transmitted by the host as the run command, please refer to [F13.09] for instructions.

When Modbus RS485 communication is valid, the running command is set and modified by address 0x3001/0x2001. See Appendix 2: Modbus Communication Protocol for details.

When the Profibus-DP communication is valid, the running command is set and modified by the corresponding address, see the Profibus-DP card instruction manual of the optional card.

3: Option card

The operation and stop of the inverter are controlled by the external optional card communication. For the installation method and parameter setting of the optional card, please refer to the instruction manual of the same box with the optional card.

Note:

1. STOP/RESET of keypad, reset command from control terminal or RS485 communication are all enabled

when fault reset.**Tips:**

2. The function of the STOP/RESET button of the keyboard can be selected. When external terminal control or communication control, it can be defined as the function of stop button, please refer to parameter [F04.08]; when using external terminal for running control, if using STOP of keyboard When the /RESET key is stopped, the inverter will stop and block the external terminal running command. At this time, the external terminal stop command must be input to unlock, and the external terminal running command is valid again. The communication control is the same.

F00.03	Frequency given source channel A	Setting range: 0~11	Default: 0
F00.04	Frequency given source channel B	Setting range: 0~11	Default: 2

Select the given source of the inverter set frequency in [F00.03], [F00.04]; [F00.06] sets the relationship between channel A and channel B.

0: Keyboard number given

The set frequency is given by the parameter [F00.08] keyboard digital setting frequency; the current setting value of the parameter [F00.08] can be quickly modified by selecting the [F04.09] LED single digit selection keyboard up/down keys; Value power-down storage and up/down key action limit selection can be found in parameter [F04.09].

1: Reserved**2: Voltage/Current analog AI1 given****3: Voltage/Current analog AI2 given**

The set frequency is given and modified by the input analog quantity AI1, AI2. By linearizing the input analog quantity value, the calibration 100% corresponds to the maximum frequency. For details, see "F03" parameter group analog quantity processing.

4: Reserved**5: Terminal pulse PUL given**

The set frequency is given and modified by the control terminal (PUL) input pulse signal; by linearizing the input pulse signal, the calibration is 100% corresponding to the maximum frequency, see parameter [F02.27~F02.33] for details.

6: RS485 communication given

The set frequency is given by the communication method. For the communication parameter setting, please refer to the F13 communication control parameter group.

When the peer-to-peer broadcast communication, the slave selects the host to transmit the given frequency or output frequency as the set frequency, please refer to [F13.09] for instructions. When Modbus RS485 communication is valid, the set frequency can be set and modified by address 0x3000/0x2000. See Appendix 2: Modbus Communication Protocol.

When the Profibus-DP communication is valid, the set frequency is set and modified by the corresponding address. See the Profibus-DP card instruction manual of the optional card.

When the CAN-RS485 communication is valid, the set frequency is set and modified by the corresponding address. See the instruction manual of the optional CAN-RS485 card.

7: Terminal UP/DW control

The set frequency is controlled by the control terminal to increase and decrease, and the "frequency increment (UP)" terminal and the "frequency decrement (DW)" terminal and (COM) of the multi-function terminal (X1 to X10) are controlled to be turned on and off. For details, see the parameter description of the [F02.00-F02.09] terminal.

8: PID control given

When [F00.03] or [F00.04] selects the channel, the inverter running mode is process PID control, the set frequency is the output after PID action, the PID control gives the quantitative and feedback quantity and other control parameters. The process PID controls the parameter group "F11".

The current set value of the parameter [F11.01] can be quickly modified by selecting the [F04.09] LED single digit up/down key. The parameter value power-down storage and up/down key action limit selection are detailed in the parameter [F04.09].

The status and characteristics of the PID control can be changed through the multi-function input terminal. For details, see the parameter description of the [F02.00-F02.09] terminal.

9: Program control (PLC) given

The set frequency and the running direction of the inverter are controlled by the process of the simple PLC inside the inverter, and the process can control up to 15 speeds. For details, see parameter "F12" multi-speed, PLC function and swing frequency parameter group;

If a speed running time is set to "0", the program speed is skipped when the program is running, which makes it easy to set the speed of the program running. When the parameter [F00.16] LED hundred bit is set to "0", the frequency control direction is invalid or [F00.16] LED tens place is set to "1", when reverse rotation is prohibited, if any speed running command direction setting. In order to reverse, the inverter runs at a frequency of 0.00 Hz at this speed.

Both the program operation and the multi-speed operation are to realize the variable speed operation of the inverter according to a certain rule. In multi-speed operation, multi-speed switching and running direction change are realized by different combinations of "multi-speed control terminals 1-4" and (COM) defined in "multi-function input terminal". The program running function can not only define the multi-segment frequency of one cycle in the function parameters, but also the time, direction, acceleration/deceleration time and cycle mode of multi-segment frequency operation can also be defined in the function parameters. The multi-speed control terminal can be defined by any multi-function terminal. For details, refer to the parameter description of the [F02.00-F02.09] terminal.

10: Optional card

The setting frequency is given and modified by the external optional card communication. For the installation method and parameter setting of the optional card, please refer to the instruction manual of the same box with the optional card.

11: Multi-steps speed given

The set frequency is selected by the "multi-speed terminal". If the frequency channels A and B are not selected for the multi-speed reference, the multi-speed terminal has a higher priority to switch the frequency to the multi-speed reference; if A, B, When a multi-speed speed reference is selected for one channel, the combination of frequency source settings is performed. When the multi-speed terminal is invalid, the multi-speed speed is given as zero. For the "multi-speed terminal", please refer to the parameter description of the [F02.00-F02.09] terminal.

F00.05	Frequency channel B reference source	Setting range: 0~1	Default: 0
--------	--------------------------------------	--------------------	------------

The reference source of the frequency reference channel B is selected by this parameter, and the reference source

of the frequency reference channel A is the maximum frequency [F00.09].

0: reference source with maximum frequency**1: Use channel A to set the frequency as the reference source**

Channel B setting frequency = Channel B frequency reference source × Channel A setting frequency absolute value / Maximum frequency

F00.06	Frequency given source selection	Setting range: 0~5	Default: 0
--------	----------------------------------	--------------------	------------

Uses for selecting frequency given A channel and B channel combination.

0: Channel A is valid only for channel A[F00.03], and channel B[F00.04] is invalid.

1: Channel B is valid only for channel B[F00.04], and channel A[F00.03] is invalid.

2: Channel A+channel B Channel A [F00.03] sets the frequency plus channel B[F00.04] setting frequency, and the sum of the two is the frequency set by the inverter.

3: Channel A-channel B Channel A[F00.03] sets the frequency minus the channel B[F00.04] setting frequency. The difference between the two is the frequency set by the inverter. This method may generate a negative frequency. . Whether the output is valid when a negative frequency is generated is determined by the [F00.16] setting.

4: Maximum value of channel A and channel B Channel A [F00.03] set frequency and channel B [F00.04] set frequency to take the maximum value, the larger is the inverter set frequency.

5: Minimum value of channel A and channel B Channel A [F00.03] set frequency and channel B [F00.04] set frequency to take the minimum value, the smaller is the inverter set frequency.

Notes:

- When the jog run command is valid, the jog set frequency is used as the inverter set frequency.
- No multi-speed speed is selected for channels A and B. If multi-speed terminal selection is valid, the corresponding frequency is selected as the inverter setting frequency.
- When the given sources selected by channels A and B are the same, no superposition calculation is performed, and the given source frequency of channel A is used as the set frequency of the inverter.
- Frequency given source priority: From high to low, it is jog running frequency setting, multi-speed speed setting, running command bundling given frequency, frequency given source channel.
- If the rotation direction selection [F00.16] is set to reverse prohibition, the inverter will output a frequency of 0.00Hz regardless of the value of the frequency control direction selection and the frequency calculation result is negative.

Tips:

- The given frequency after the combination of frequency reference channel A and frequency reference channel B is still limited by the upper limit frequency and lower limit frequency.

F00.07	Running Command Binding	Setting range: 0000~DDDD	Default: 0000
--------	-------------------------	--------------------------	---------------

When this parameter is valid, it is used to set the channel source frequency channel for each running command channel. When the command source has a bundled frequency source, the set frequency is given by the frequency source bundled by [F00.07], and the set frequency obtained by [F00.03-F00.06] will no longer be used. Effective, but

[F00.16] LED hundred-bit frequency direction control is still valid.

LED "0" digit: keyboard command bundle

- 0: No binding Press the [F00.03~F00.06] setting to determine the frequency reference.
- 1: keyboard digital given frequency
- 2: Reserved
- 3: Voltage / current analog AI1 given
- 4: Voltage/current analog AI2 given
- 5: reservations
- 6: Terminal pulse PUL given
- 7: RS485 communication given
- 8: Terminal UP/DW control
- 9: PID control given
- A: Program control PLC given
- B: Option card
- C: multi-speed speed given
- D: Reserved

The above 1~12 items are the same as the frequency given channel A selection [F00.03].

LED "00" digit: terminal command bundle

The setting range of 1~12 is the same as the LED ones: the keyboard command instruction bundle description is consistent

LED "000" digit: Communication command bundle

The setting range of 1~12 is the same as the LED ones: the keyboard command instruction bundle description is consistent.

LED "0000" digit: Optional card command bundle

The setting range of 1~12 is the same as the LED ones: the keyboard command instruction bundle description is consistent.

Examples: If remote/in-place switching is used, the remote mode uses the communication command reference and frequency reference. The local mode uses the terminal command reference and the keyboard digital frequency reference.

The setting parameters are as follows: [F00.02=2: Communication Control] [F00.03=6: Communication Reference] [F00.07=0010: Ten-digit terminal command bundled keyboard digital reference frequency] [F02.04=49 : Command channel is switched to terminal].

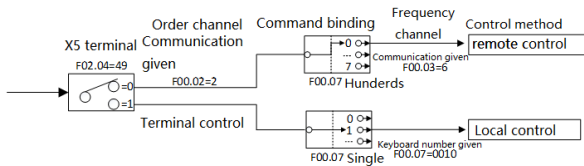

F00.08	Keyboard digital setting frequency	Set range: 0.00~Upper limit frequency	Default: 50.00Hz
--------	------------------------------------	---------------------------------------	------------------

This parameter is valid when the frequency reference channel [F00.03, F00.04] is set to "0: Keyboard Digital Reference" and is used to set and modify the keyboard digital setting frequency.

F00.09	Max frequency output	Setting range: Upper limit frequency~600.00Hz	Default: 50.00Hz
F00.10	Upper limit frequency source selection	Setting range: 0~7	Default: 0
F00.11	Upper frequency limit digital setting	Setting range: Lower limit frequency~Max frequency	Default: 50.00Hz
F00.12	Lower limit frequency	Setting range: 0.00~Upper limit frequency	Default: 0.00Hz
F00.13	Lower limit frequency running mode	Setting range: 0~1	Default: 1

Maximum frequency:

When the analog input, pulse input (PUL), multi-speed, etc. in the inverter are used as the frequency source, 100% of each is the relative maximum frequency calibration; when the [F01.16] LED bits are set to "0", the maximum The frequency is used as the reference frequency for the acceleration/deceleration time.

Upper frequency source selection:

Select a given source for the upper limit frequency of the drive. The upper limit frequency is the upper limit of the given frequency and limits the given frequency.

- 0: Upper limit frequency digital reference Set by parameter [F00.11].
- 1: reserved
- 2: voltage / current analog AI1 given
- 3: voltage / current analog AI2 given
- 4: Reserved
- 5: terminal pulse PUL given
- 6: RS485 communication setting Set by address 0x3004/0x2004, please refer to Appendix 2: Modbus Communication Protocol
- 7: Option card

When using keyboard potential, analog (AI1, AI2), terminal pulse (PUL), RS485 communication reference, and optional card, similar to frequency reference channel A, please refer to [F00.03].

Upper limit frequency digital setting:

The upper limit frequency is given to the channel when [F00.10] is set to "0".

Lower limit frequency:

The lower limit frequency is the lower limit of the given frequency and limits the given frequency.

When the set frequency is lower than the lower limit frequency, the inverter sets the lower limit frequency operation mode by [F00.13].

Lower limit frequency operation mode:

0: Stop output, enter the pause operation state, maintain the running state, no voltage output.

1: Lower limit frequency operation When the actual set frequency is lower than the lower limit frequency, the inverter runs at the limit frequency.

Note:

- The maximum frequency, upper limit frequency and lower limit frequency should be set carefully according to the requirements of the operating conditions. In addition to the upper limit frequency and lower limit frequency, the output frequency of the inverter during operation is also limited by the set values of the start frequency, stop detection frequency, stop DC brake start frequency, and skip frequency. The relationship between the maximum frequency, upper limit frequency and lower limit frequency is shown in the figure below.

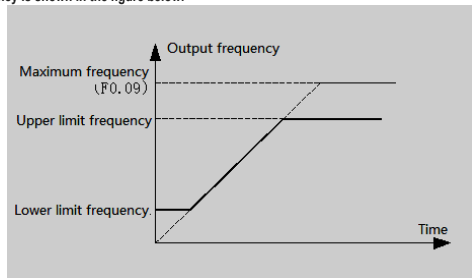

Schematic diagram of upper and lower frequency and maximum frequency

F00.14	ACC time 1	Setting range: 0.00~650.00s	Default: Model setting
F00.15	DEC time 1	Setting range: 0.00~650.00s	Default: Model setting

The acceleration time refers to the time required for the output frequency to accelerate from 0.00 Hz to the time reference frequency, and the deceleration time refers to the time required for the output frequency to decelerate from the time reference frequency to 0.00 Hz. The maximum frequency, fixed frequency 50Hz, and given frequency can be selected as the time reference frequency by parameter [F01.16] LED bits. The acceleration/deceleration curve is selected by [F01.16] LED ten-digit line and S-curve acceleration/deceleration. See parameter [F01.16] for details.

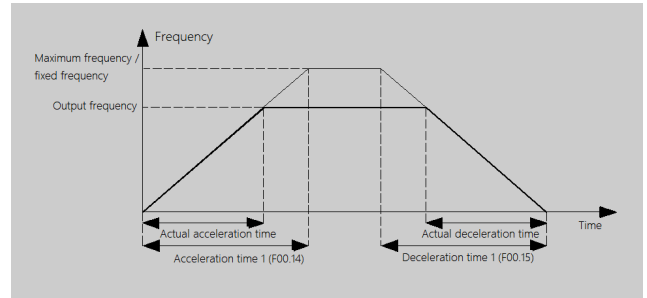

Four groups of acceleration and deceleration time can be selected for normal frequency acceleration and deceleration. Acceleration/deceleration time 1 is set by [F00.14-F00.15], acceleration/deceleration time 2, acceleration/deceleration time 3, and acceleration/deceleration time 4 are set by [F01.21-F01.26]. Acceleration/deceleration time 1 is the default acceleration/deceleration time group. If you want to select other acceleration/deceleration time group, you can select it through the control terminal. For details, see parameter [F02.00-F02.09].

When the program is running, each of the program running segments can select one of the four groups of acceleration and deceleration time, regardless of the terminal selection. See [F12.31-F12.45] for details.

The jog acceleration and deceleration time are set by [F01.39, F01.40].

The emergency stop deceleration time is set by [F01.27].

F00.16	Rotary direction selection	Setting range: 0000~0121	Default: 0000
--------	----------------------------	--------------------------	---------------

LED "0" digit: reverse the running direction

Used to select the adjustment of the motor running control direction.

0: The direction is unchanged The actual steering of the motor is the same as the required steering, and the current motor direction is not adjusted;

1: Inverted direction The actual steering of the motor is opposite to the required steering, and the current motor direction is adjusted;

LED "00" digit: no direction of operation

Used to select the effectiveness of the motor's running control direction.

0: Allow forward and reverse commands The inverter accepts forward and reverse commands to control motor operation;

1: Only forward command is allowed. The inverter only accepts the forward rotation control command to control the motor operation. If the inverter is given the reverse command, the inverter will not run.

2: Only reverse command is allowed. The inverter only accepts the reverse control command to control the motor operation; if the forward rotation command is given, the inverter will not run.

LED "000" digit: frequency control direction selection

It is used to select whether the negative frequency is allowed to change the current running direction of the inverter when the frequency reference value is negative.

0: Invalid frequency control direction If the calculation result is negative, the inverter outputs a frequency of 0.00Hz.

1: Frequency control direction is valid If the calculation result is negative, the inverter changes the current running direction and outputs the corresponding frequency.

Tips:

- The set value of this parameter will not be changed when the factory value is restored. When this parameter is set to a value, all commands that run the command channel (operating keyboard, external terminal, RS485 communication, optional card, and program operation) are affected by the selected value.

F00.17	G/P Model Setting	Setting range: 0~1	Default: 0
--------	-------------------	--------------------	------------

The set value of this parameter will not be changed when the factory value is restored.

0: **Model G** is suitable for constant torque loads.

1: **Model P** type machine Suitable for variable torque load (fan, pump type load).

The AC300 series inverter adopts the G/P combination method for constant torque load (G type) to adapt the motor power ratio to the fan water. The pump type load (P type) is a small one.

F00.18	Reserved		
--------	----------	--	--

F00.19	Parameter initialization	Setting range: 0~3	Default: 0
--------	--------------------------	--------------------	------------

0: no operation

1: Restore factory value (do not restore motor parameter F05.00-F05.19) After the parameters are restored to the factory default values, the function parameters are restored to the default values before leaving the factory, excluding the motor parameter group.

2: Restore factory defaults (including motor parameters F05.00-F05.19) After the parameters are restored to factory defaults, the function parameters are restored to the factory default values and restored together with the motor parameter group.

3: Clear fault record Clear all historical fault information recorded in [C01.00~C01.23].

Tips:

- The factory default setting [F00.19=1 or 2] is restored, and the current setting values of the parameters [F00.16-F00.17] and [F04.14-F04.21] are not changed.
- When the factory default value is restored, the keyboard will display "SAVE". After the "SAVE" jumps to the parameter interface, the parameter initialization is completed. If the power is suddenly turned off during the display of "SAVE", the inverter only performs some parameters to restore the factory values. Please power on again to restore the factory values.

8.2 Operation Control Parameters Group

F01.00	Start-up running mode	Setting range: 0~2	Default: 0
F01.01	Start pre-excitation time	Setting range: 0.00~60.00s	Default: Model setting
F01.02	Start-up frequency	Setting range: 0.00~60.00Hz	Default: 0.50Hz
F01.03	Start-up frequency holding time	Setting range: 0.0~50.0s	Default: 0.0s
F01.04	Braking current before start	Setting range: 0.0~150.0%	Default: 60.0%
F01.05	Braking time before start	Setting range: 0.0~60.0s	Default: 1.0s

Start mode:

0: Start the inverter by the starting frequency and control the inverter to start with the starting frequency set by [F01.02] and the starting frequency duration set by [F01.03]. It is suitable for occasions where the static friction torque is large and the load inertia is small or when the user cooperates with an external mechanical brake device. (After the motor stops, it will start again. If the motor is in the rotating state before starting, it may cause overcurrent fault.)

1: First DC braking and then starting from the starting frequency Firstly, the pre-starting braking current [F01.04] and the pre-starting braking time [F01.05] apply a certain amount of DC braking energy to the load motor (ie electromagnetic brake), and then start from the starting frequency; suitable for small inertia loads with forward or reverse rotation in the stop state.

2: Start after the speed tracking and direction judgment. The inverter first detects the speed and direction of the motor, and then starts to increase to the given frequency according to the acceleration/deceleration time at the detected speed.

Start pre-excitation time:

This parameter is used to set the time for pre-excitation of the asynchronous motor at startup. This parameter can establish a magnetic field before the motor starts, which can effectively improve the starting performance of the motor and reduce the starting current and starting time.

Start frequency:

It is the initial output frequency when the inverter starts. Setting a suitable starting frequency can have a higher starting torque. For some loads with a large static friction at rest, some momentum can be obtained at the moment of starting. However, if the set value is too large, problems such as E.oC1 may occur.

Start frequency duration:

It refers to the time when the inverter maintains the starting frequency and starts to enter normal acceleration and deceleration after the time is maintained.

Braking current before starting:

It refers to the amount of braking current that the inverter sends into the motor during DC braking. 100.0% corresponds to the rated current of the motor. The DC braking function at start-up is only available when [F01.00] is set to "1". Setting this parameter to 0 starts DC braking execution is invalid.

Braking time before starting:

It refers to the duration of DC braking current at startup; only when [F01.00] is selected as "1", there will be DC braking function at startup; when braking time is 0.0 seconds, there is no DC braking process.

Note:

1. The starting frequency is not limited by the lower limit frequency [F00.12] and the zero speed torque frequency threshold [F01.29].

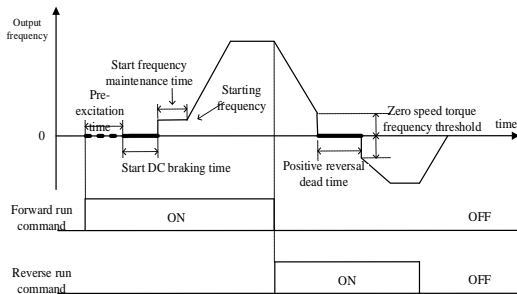

Startup and forward and reverse switching process diagram

F01.06	Speed tracking time	Setting range: 0.00~60.00s	Default: 0.50s
F01.07	Speed tracking delay when stop	Setting range: 0.00~60.00s	Default: 1.00s

Speed tracking speed:

It refers to the time taken by the output voltage to increase to the normal voltage at the current speed during the start of the inverter speed tracking. The shorter the time, the faster the tracking process, but the greater the current impact generated by the tracking process. The internal speed of the inverter is automatically controlled.

Speed tracking stop delay:

It means that after the inverter cuts off the output, it takes a certain delay to re-output the voltage to start the motor, so that the inrush current at startup is as small as possible. When the time is zero, the delay is automatically controlled by the inverter.

F01.08- F01.09	Reserved
----------------	----------

F01.10	Stop mode	Setting range: 0~1	Default: 0
--------	-----------	--------------------	------------

0: deceleration stop

According to the set deceleration time and deceleration mode, the inverter stops output after decelerating to the frequency of 0.00Hz.

During the deceleration stop, when the output frequency is less than the stop DC braking start frequency [F01.11], the output frequency of the inverter will jump to zero, DC braking will be performed and the operation will be stopped after execution; otherwise the inverter will decelerate to Stop working after the minimum output frequency.

1: Free stop

The inverter blocks the output immediately after receiving the stop command, and the motor runs freely until it stops. When this mode is selected, it is generally combined with an external mechanical brake to achieve rapid stop.

F01.11	DC braking initial frequency when stop	Setting range: 0.00~50.00Hz	Default: 1.00Hz
F01.12	DC braking current when stop	Setting range: 0.0~150.0%	Default: 60.0%
F01.13	Reserved		
F01.14	DC braking hold time when stop	Setting range: 0.0~60.0s	Default: 0.0s

Stop DC braking start frequency:

It means that when the inverter decelerates to this frequency, it will stop output and start DC braking function; when it stops, when the output frequency is lower than the stop DC braking start frequency, the DC braking function will be activated.

During the deceleration stop, when the given frequency is less than the stop DC braking start frequency, DC braking is started and the output frequency of the inverter jumps to zero. If the operating conditions do not have strict requirements for the stop brake, the DC brake start frequency should be set as small as possible during the stop.

DC braking current at stop:

It refers to the amount of braking current that the inverter sends into the motor during DC braking. This value 100.0% corresponds to the rated motor current.

The DC braking function provides zero speed torque. It is usually used to improve the shutdown accuracy and achieve a quick stop, but it cannot be used for deceleration braking during normal operation; that is, once DC braking is started, the inverter will stop output. The DC braking current setting is too large, and an overcurrent fault is likely to occur when the inverter is stopped. If this parameter is set to 0, the stop DC brake execution is invalid.

Stop DC braking duration:

It refers to the time when the DC braking current lasts during the stop. When the braking time is 0.0 seconds, there is no DC braking process, that is, the DC braking function is invalid. If this parameter is set to 0, the stop DC brake execution is invalid.

F01.15	Stop detection frequency	Setting range: 0.00~50.00Hz	Default: 0.50Hz
--------	--------------------------	-----------------------------	-----------------

Stop detection frequency:

When the speed is reduced, the inverter will enter the stop state when the output frequency is less than this value.

F01.16	ACC/DEC selection	Setting range: 0000~0012	Default: 0010
F01.17	ACC start time for S curve	Setting range: 0.00~10.00s	Default: 0.20s
F01.18	ACC end time for S curve	Setting range: 0.00~10.00s	Default: 0.20s
F01.19	DEC start time for S curve	Setting range: 0.00~10.00s	Default: 0.20s
F01.20	DEC end time for S curve	Setting range: 0.00~10.00s	Default: 0.20s

Acceleration and deceleration selection

LED "0" digit: acceleration/deceleration time reference frequency

This parameter is used to select the basis for the acceleration/deceleration time.

0: Maximum frequency The reference for the acceleration/deceleration time is the maximum frequency [F00.09].

1: Fixed frequency The reference for the acceleration/deceleration time is 50.00 Hz fixed frequency.

2: Setting frequency The reference of acceleration/deceleration time is the set frequency. If the set frequency changes frequently, the acceleration of the motor will change, so pay attention to the application.

LED "00" digit: acceleration and deceleration mode

This series of inverters provides two kinds of acceleration and deceleration modes; two kinds of acceleration and deceleration modes are valid during normal start, stop, forward and reverse, acceleration and deceleration.

0: Straight line Generally suitable for general purpose loads.

1: S curve S-type acceleration and deceleration curves are mainly provided to reduce noise and vibration during acceleration and deceleration, reduce the start-stop impact or low-frequency need to reduce the torque, and the high-frequency needs short-time acceleration and other loads.

LED "000" digit: Reserved

LED "0000" digit: Reserved

The characteristics of the S curve during forward and reverse rotation are as follows:

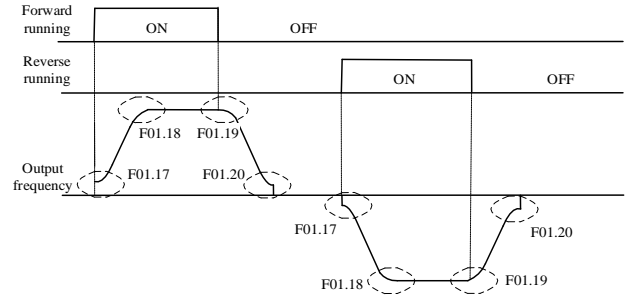

Schematic diagram of S curve

Tips:

- After setting the S curve, the acceleration/deceleration time will be extended as follows:
 Acceleration time = selected acceleration time + ((F01.17)+[F01.18])/2
 Deceleration time = selected deceleration time + ((F01.19)+[F01.20])/2
- The acceleration S curve is divided into three segments. Start S curve time [F0.14], acceleration time [F0.14], end S curve time [F1.18]. Total acceleration time = acceleration time [F0.14] + (([F1.17]+[F1.18])/2, try to ensure the selected acceleration time [F0.14] ≥ (([F1.17]+ [F1.18])/2. When [F0.14] < (([F1.17]+ [F1.18]) /2, the total acceleration time will be calculated by the software itself and will deviate from the set time.
- The deceleration S curve is the same as the acceleration S curve.

F01.21	ACC time 2	Setting range: 0.01~650.00s	Default: 10.00s
F01.22	DEC time 2	Setting range: 0.01~650.00s	Default: 10.00s
F01.23	ACC time 3	Setting range: 0.01~650.00s	Default: 10.00s
F01.24	DEC time 3	Setting range: 0.01~650.00s	Default: 10.00s
F01.25	ACC time 4	Setting range: 0.01~650.00s	Default: 10.00s
F01.26	DEC time 4	Setting range: 0.01~650.00s	Default: 10.00s

Acceleration time 2/3/4:

When the parameter [F01.16] LED "0" digit is set to "0", it refers to the time required for the output frequency to accelerate from 0.00Hz to the maximum frequency;

When the parameter [F01.16] LED "0" digit is set to "1", it refers to the time required for the output frequency to accelerate from 0.00Hz to 50.00Hz;

When the parameter [F01.16] LED "0" digit is set to "2", it refers to the time required for the output frequency to accelerate from 0.00Hz to the set frequency;

See parameter [F01.16] for details.

Deceleration time 2/3/4:

When the parameter [F01.16] LED bit is set to "0", it refers to the time required for the output frequency to decelerate from the maximum frequency to 0.00Hz;

When the parameter [F01.16] LED bit is set to "1", it refers to the time required for the output frequency to decelerate from 50.00 Hz to 0.00 Hz;

When the parameter [F01.16] LED bit is set to "2", it refers to the time required for the output frequency to decelerate from the set frequency to 0.00Hz;

See parameter [F01.16] for details.

Acceleration/deceleration time 2/3/4 can only switch the current acceleration/deceleration time group by the combination of the multi-function terminal "acceleration/deceleration time selection terminal 1" and "acceleration/deceleration time selection terminal 2" and (COM) (PLC program Except for operation); if the acceleration/deceleration time selection terminal is not set, the factory default value is that the acceleration/deceleration time 1 is valid, and the inverter performs acceleration/deceleration according to the acceleration/deceleration time 1.

The definition of the acceleration/deceleration time of the PLC program operation is detailed in the parameters [F12.31~F12.45].

The jog acceleration/deceleration time is not within this range, and the jog acceleration and deceleration time are individually set by [F01.39, F01.40].

Acceleration and deceleration time selection comparison table:

Terminal 2	Terminal 1	Acc/Dec time selection
OFF	OFF	Acc time 1/ Dec time 1
OFF	ON	Acc time 2/ Dec time 2
ON	OFF	Acc time 3/ Dec time 3
ON	ON	Acc time 4/ Dec time 4

If you have doubts about the above table, you can refer to the multi-speed multi-speed timing diagram of the "F12" parameter group.

F01.27	DEC time at emergency stop	Setting range: 0.01~650.00s	Default: 1.00s
--------	----------------------------	-----------------------------	----------------

It's used to set the deceleration time during emergency stop. The definition of emergency stop time is the same as the deceleration time. Please set the emergency stop time according to the site conditions to avoid over-current and over-current caused by abnormality. Over-voltage affects the deceleration time.

The emergency stop function can only be triggered by the input terminal (terminal function is set to "7: emergency stop"). For details, see parameter [F02.00~F02.09] IO terminal, [F03.12, F03.15] AI2 terminal.

When the multi-function output terminal is set to "26: Emergency stop", the output terminal always outputs a valid signal during the emergency stop.

See parameter [F02.43~F02.50] for details.

F01.28	FWD&REV dead time	Setting range: 0.0~120.0s	Default: 0.0s
--------	-------------------	---------------------------	---------------

Positive and negative dead time:

This function is defined as the transition time that the inverter waits at 0.0Hz during the process from forward to reverse, or from reverse to forward rotation. The positive and negative dead time is mainly for large inertia load and there is machinery when changing steering. Set for the device in the dead zone.

F01.29	Zero speed torque frequency threshold	Setting range: 0.00~10.00Hz	Default: 0.50Hz
F01.30	Zero speed torque coefficient	Setting range: 0.0~150.0%	Default: 60.0%
F01.31	Zero speed torque holding time	Setting range: 0.0~6000.0s	Default: 0.0s

Zero speed torque function:

It is effective under open loop V/F or open loop vector to set the output torque and duration of the inverter at zero speed.

Invalid in closed-loop control mode (the motor can achieve zero servo function under closed-loop control.)

Zero speed torque frequency threshold: set the frequency threshold of the inverter to enter the zero speed state, as the judgment of the inverter entering the zero speed torque holding state one of the broken conditions.

Zero speed torque retention factor:

Set the output torque of the inverter when running at zero speed, 100% corresponds to the rated current of the motor.

Zero speed torque holding time:

Set the time to keep the motor output torque after the inverter enters the zero speed torque state.

[F01.31] When the set value is 0~5999.9s, the timer will start when the inverter enters the zero speed torque state (operating frequency is 0Hz). After the time reaches the set value, the inverter will stop zero speed torque hold and stop output. (Entering the stop state).

[F01.31] When the set value is 6000s, it will not be timed when the inverter enters the zero speed torque state (operating frequency is 0Hz). The zero speed torque state is valid for the long term by default, only after giving the stop command or given non-zero. The operating frequency only terminates the zero speed torque hold.

The zero speed torque function enters the condition judgment:

1. During the start-up speed of the inverter, when the given frequency is less than the starting frequency, the inverter output is zero, but does not enter the zero-speed torque function.

2. During the forward and reverse switching of the inverter during normal operation, when the output frequency is less than [F01.29], the output zero frequency, enter the zero speed torque function, when the zero speed torque holding time [F01.31] is greater than the positive and negative When the dead time [F01.28] is changed, the hold time is determined by the positive and negative dead time [F01.28].

3. When the inverter is in normal operation, change the frequency setting value during the speed-up and

running process. When the speed is reduced, it will output zero frequency after [F01.29], enter the zero-speed torque function, and exit zero after zero speed torque holding time. Speed torque function.

4. During the inverter deceleration process, when the output frequency is less than the zero speed torque frequency threshold [F01.29], the zero speed torque function will not be entered, and the normal deceleration will be stopped. If the stop DC braking start frequency is greater than [F01.29], when the output frequency is less than the stop DC braking start frequency, the stop DC braking state is entered.

5. When the zero speed torque frequency threshold value exceeds the starting frequency [F01.02], the internal zero speed torque frequency threshold is limited to the starting frequency.

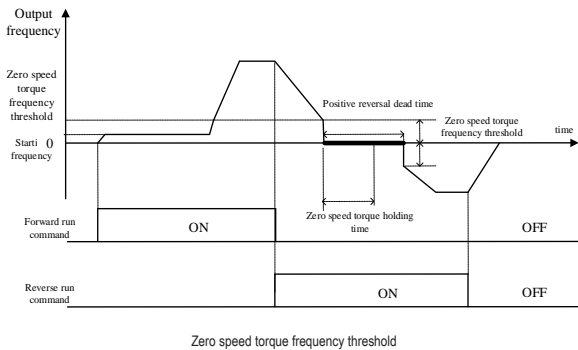

Note:

1. If the zero speed holding torque is set too large or the zero speed holding torque time is set too long, pay attention to the temperature rise of the motor. If the motor temperature rises a lot, it is necessary to improve the heat dissipation of the motor plus the heat sink of the motor.

F01.32-F01.34	Reserved		
F01.35	Power off restart action selection	Setting range: 0~1	Default: 0
F01.36	Power off restart waiting time	Setting range: 0.00~60.00s	Default: 0.50s

Power failure restart action selection:

0: Invalid After the inverter is powered off and then powered on, it must be run after receiving the running command.
 1: Valid If the inverter is in the running state before the power is cut off, after the power is restored, the inverter will start the automatic speed tracking after the waiting time set by [F01.36].

Stop restart wait time:

This function is defined as the transition time that the inverter waits and restarts at 0.0 Hz. The power failure restart wait time [F01.36] setting principle is based on factors such as the recovery recovery time of other equipment related to the inverter after power supply is restored.

During the waiting time of power failure restart, the inverter does not accept the running command, but if the stop command is input during this period, the inverter will cancel the restart state.

Notes:

1. The power failure restart function can automatically start the inverter after power is restored. Therefore, it has great contingency, please use it carefully for the safety of people and equipment.
2. Use the power failure restart function to ensure that the inverter runs valid signal before power off. When the keyboard operation control, RS485 communication control or optional card operation, if the inverter has power failure, the running command will be automatically cleared.
3. When the running command uses the terminal two-wire control, if the running terminal has no input after power-on, the inverter will not run.

F01.37	Reserved		
F01.38	JOG running frequency setting	Setting range: 0.00~Maximum frequency	Default: 5.00Hz
F01.39	JOG ACC time	Setting range: 0.01~650.00s	Default: 10.00s
F01.40	JOG DEC time	Setting range: 0.01~650.00s	Default: 10.00s

Jog running frequency setting: Set the output frequency of the inverter when jogging.

Jog acceleration time: The jog acceleration/deceleration time defines the same acceleration/deceleration time:
 When the parameter [F01.16] LED "0" digit is set to "0", it refers to the time required for the output frequency to accelerate from 0.00Hz to the maximum frequency;
 When the parameter [F01.16] LED "0" digit is set to "1", it refers to the time required for the output frequency to accelerate from 0.00Hz to 50.00Hz;
 When the parameter [F01.16] LED "0" digit is set to "1", it refers to the time required for the output frequency to accelerate from 0.00Hz to the set frequency;
 See parameter [F01.16] for details.

Jog deceleration time: Jog acceleration/deceleration time defines the same acceleration/deceleration time.
 When the parameter [F01.16] LED "0" digit is set to "0", it refers to the time required for the output frequency to decelerate from the maximum frequency to 0.00Hz;
 When the parameter [F01.16] LED "0" digit is set to "1", it refers to the time required for the output frequency to decelerate from 50.00 Hz to 0.00 Hz;
 When the parameter [F01.16] LED "0" digit is set to "2", it refers to the time required for the output frequency to decelerate from the set frequency to 0.00Hz;
 See parameter [F01.16] for details.

Note:

1. The inverter can be controlled by the jog operation command of the keyboard, control terminal, communication command or optional card.

- Terminal jog has the highest priority command right. That is, in any state, once the terminal jog command is valid, the jog acceleration/deceleration time is immediately run from the current running frequency to the jog frequency.
- Only the terminal jog run priority is not limited by the run command channel, and other jog commands have priority only when they are the same as the run command channel. For example, the keyboard jog operation is valid only when the keyboard control is running, and takes precedence over the keyboard forward/reverse run command.
- The set value of the jog running frequency is limited by the maximum frequency of [F00.09].
The actual output frequency during jog operation is limited by the upper limit frequency of [F00.11].

F01.41	Jump frequency 1	Setting range: 0.00~Maximum frequency	Default: 0.00Hz
F01.42	Jump frequency range 1	Setting range: 0.00~Maximum frequency	Default: 0.00Hz
F01.43	Jump frequency 2	Setting range: 0.00~Maximum frequency	Default: 0.00Hz
F01.44	Jump frequency range 2	Setting range: 0.00~Maximum frequency	Default: 0.00Hz

When the inverter is running with load, in order to avoid the output frequency of the inverter from the resonance frequency point of the mechanical load, the resonance frequency can be avoided by the jump frequency. The inverter can set two jumping points to perform the jump. After setting the skip frequency parameter, even if the set frequency of the inverter is within the resonant frequency point of the mechanical load, the output frequency of the inverter will be automatically adjusted to the outside of the resonant frequency of the mechanical load to avoid running at the resonance point, the skip frequency processing during acceleration and deceleration is as follows:

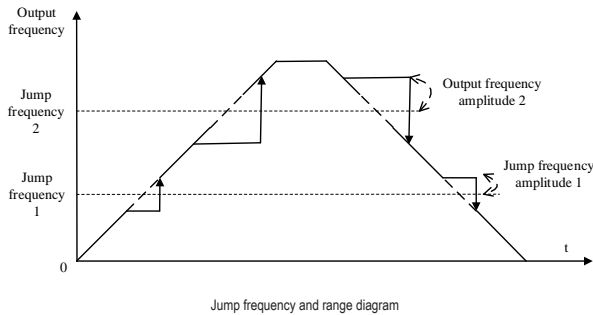

Tips: During acceleration and deceleration, the output frequency of the inverter will still pass through the jump frequency zone normally.

8.3 Switching Value Terminal Parameters

F02.00	Input terminal 1(X1)	Setting range: 0~63	Default: 1
F02.01	Input terminal 2(X2)		Default: 2
F02.02	Input terminal 3(X3)		Default: 4
F02.03	Input terminal 4(X4)		Default: 5
F02.04	Input terminal 5(X5)		Default: 39
F02.05	Input terminal 6(X6 expand)		Default: 0
F02.06	Input terminal 7(X7 expand)		Default: 0
F02.07	Input terminal 8(X8 expand)		Default: 0
F02.08	Input terminal 9(X9 expand)		Default: 0
F02.09	Input terminal 10(X10 expand)		Default: 0

This unit has 5 multi-function input terminals.

The functions of the multi-function input terminals (X1-X10) can be defined separately by the parameters [F02.00-F02.09].

Set the characteristics of the multi-function input terminal and the detection delay by parameter [F02.11-F02.22]. For details, see parameter [F02.11-F02.22].

Set the terminal characteristics of the multi-function input terminal [X5/PUL] with parameter [F02.04]. When set to "39: Frequency selection", the external terminal is a high-speed pulse port, which is used as a PUL reference function; otherwise, the external terminal is a digital signal input port, which is used as an X5 input. ([F02.09] Multi-function terminal X10/PUL settings are the same)

The multi-function input terminals are versatile and can be easily set and selected as needed. The set values and functions are as follows:

X	Function Specification	X	Function Specification
0	No function	32	ACC/DEC time selection terminal 1
1	FWD	33	ACC/DEC time selection terminal 2
2	REV	34	ACC/DEC pause
3	3-line running(Xi)	35	Swing frequency input
4	FWD JOG	36	Swing frequency pause
5	REV JOG	37	Swing frequency reset
6	Free stop	38	Keyboard self-test
7	Emergency stop	39	Frequency selection
8	Malfunction reset	40	Timer trigger terminal
9	External malfunction input	41	Timer clear terminal
10	Frequency UP	42	Counter input terminal
11	Frequency DW	43	Counter clear terminal
12	UP/DW clear	44	DC braking command
13	Switch channel A to channel B	45	Pre excitation command terminal

14	Channel combination switch to A	46	Motor selection terminal
15	Channel combination switch to B	47	Reserved
16	Multispeed terminal 1	48	Command channel switch to keyboard
17	Multispeed terminal 2	49	Command channel switch to terminal
18	Multispeed terminal 3	50	Command channel switch to communication
19	Multispeed terminal 4	51	Command channel switch to expansion card
20	PID control cancel	52	Operation banned
21	PID control pause	53	Forward banned
22	PID trait switch	54	Reverse banned
23	PID gain switch	55	Speed torque control switch
24	PID given switch 1-3	56	Position control switch
25	PID feedback switch1-3	57	Command channel switch to keyboard
26	PLC pause	58	Command channel switch to terminal
27	PLC restart	59	Command channel switch to communication
28	PID control cancel	60	Command channel switch to expansion card
29	PID control pause	61	Operation banned
30	PID trait switch	62	Reserved
31	PID gain switch	63	Reserved

0: no function

Indicates that the terminal is invalid. If the terminal function is idle, it is recommended to set it to "0" to prevent misoperation.

1: Forward running

When the running command is given by the terminal, if [F02.23] is set to "0: two-wire system 1", the inverter will run forward when the terminal is valid. For other control modes, see parameter [F02.23]; Start the protection feature reference parameter [F02.24].

2: Reverse running

When the running command is given by the terminal, if [F02.23] is set to "0: two-wire system 1", the inverter will run in reverse when the terminal is valid. For other control modes, see parameter [F02.23]; Start the protection feature reference parameter [F02.24].

3: Three-wire operation control (Xi)

When the running command is given by the terminal, if [F02.23] is set to "2(3): three-wire system 1(2)", the terminal is the three-wire operation control terminal (Xi). For details, see parameter [F02. 23]; At the same time, the startup protection feature is invalid. For details, see parameter [F02.24]

4: Forward turning

5: Reverse jog

Positive and negative jog command input port. When this terminal is valid, the inverter will jog. The terminal jog command has the highest priority. See [F01.38-F01.40] for detailed setting of jog parameters and reference parameter [F02.24] for jog protection characteristics.

6: Free parking

When the terminal is valid, the inverter immediately blocks the output, and the motor is in free running state.

When the free stop terminal is always active, the drive will not accept any start command and remain stopped.

When the keyboard, RS485, optional card and terminal three-wire control are running, after the free stop terminal command is released, the original operation command will not be restored. If the inverter needs to be started, the operation command must be re-entered.

7: Emergency stop

If an emergency stop command is input during the operation of the inverter, the inverter will decelerate to a stop with the deceleration time set by [F01.27]. For details, please refer to [F01.27] Emergency stop deceleration time.

After entering the emergency stop command, it cannot be re-run until the inverter has completely stopped. If the stop mode [F01.10] is set to free stop, the inverter will still perform emergency stop deceleration according to the emergency stop time.

When the emergency stop terminal is always active, the inverter will not accept any start command and keep the stop command status. When the terminal two-wire control is running, whether the original operation command is restored after the emergency stop terminal command is released, refer to the parameter setting of [F02.24].

When the keyboard, communication, optional card and terminal three-wire control are running, the original stop command is not restored after the emergency stop terminal command is released. To start the drive, you need to re-enter the run command.

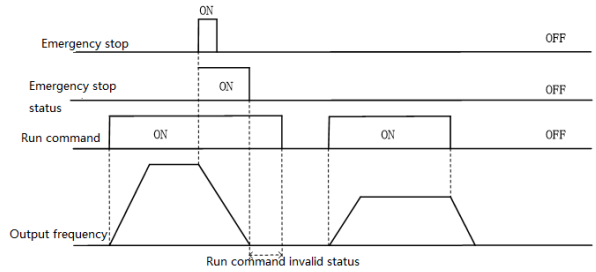

Emergency stop command diagram

Notes: Sudden deceleration can cause the inverter to generate an overvoltage fault. When an overvoltage fault occurs, the output of the inverter will be cut off and the motor will run freely, which will cause the motor to be out of control. Therefore, when using the emergency stop function, set the appropriate deceleration time in [F01.27] or use it with the energy consumption brake function.

8: Fault reset

When the inverter has a fault alarm, the fault can be reset through this terminal. When the two-wire control of the terminal is running, whether the original operation command is restored after the fault is reset, refer to the parameter setting of [F02.24].

9: External fault input

Through this terminal, the fault signal of the external device can be input, which is convenient for the inverter to

monitor and protect the fault of the external device. After the inverter receives the external fault input signal, it immediately blocks the output, the motor is in free running state, and the fault information E.EF is displayed.

10: Frequency increment (UP)

11: Frequency decrement (DW)

The increment (UP) and decrement (DW) of a given frequency are achieved by the control terminals. Only valid when parameter [F00.03] is set to "7" terminal UP/DW control.

You can set the memory and clear mode after adjusting the frequency by UP and DW through [F02.34]. For details, see parameter [F02.34].

The acceleration/deceleration rate of the given frequency can be controlled by the [F02.35] setting terminal UP/DW. For details, see parameter [F02.35].

12: Frequency increment decrements clear (UP/DW clear)

UP, DW adjustment frequency can be cleared at any given time by the "frequency increment decrement clear (UP / DW clear)" terminal to clear its given frequency.

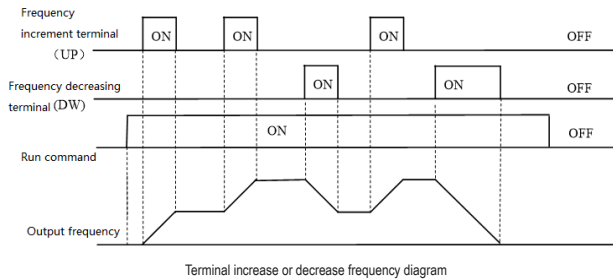

13: Channel A switches to channel B

14: Frequency channel combination is switched to channel A

15: Frequency channel combination is switched to B

The frequency is given to the fixed channel combination through the terminal.

16: multi-speed terminal 1

17: Multi-speed terminal 2

18: Multi-speed terminal 3

19: Multi-speed terminal 4

The input port of the multi-speed command, the code combination realizes 15 speeds; the multi-speed command has priority next to the jog command. For details, see the setting instructions of the [F12.00~F12.14] parameters.

20: PID control canceled

When the terminal is valid, the process PID function can be disabled, the PID output and internal state are forcibly cleared. When the terminal is invalid, the PID restarts calculation.

21: PID control pause

When the terminal is valid, the process PID function can be suspended, and the PID output and internal state maintain the current value. When the terminal is invalid, the PID continues to operate based on the current value.

22: PID feature switching

When this terminal is valid, the PID feedback characteristic of the LED bit setting of parameter [F11.07] will change. When the terminal is invalid, the PID output characteristic will be changed to the PID of the LED bit setting of [F11.07]. Feedback characteristics.

23: PID parameter switching

This terminal selection is valid when the PID parameter switching condition [F11.17] is set to "1". When the function is invalid, the PID adjustment ratio, integral, and derivative parameters are [F11.11~F11.13], and when valid, [F11.14~F11.16].

24: PID given switch 1

25: PID given switch 2

26: PID given switch 3

When the PID controller's given signal source [F11.00] is set to "8" terminal selection, the channel of the PID controller's given signal source is switched through the group terminal. For details, see parameter [F11.00]

27: PID feedback switch 1

28: PID feedback switch 2

29: PID feedback switch 3

When the PID controller feedback signal source [F11.03] is set to "8" terminal selection, the channel of the PID controller feedback signal source is switched through this group terminal. For details, see parameter [F11.03].

30: Program operation (PLC) is suspended

When the frequency reference main channel selection [F00.03] is set to "9: Program control (PLC) reference", during the running of the program, the signal is valid to suspend the program operation, and the inverter runs at the current segment frequency. After the signal disappears, it continues to run in the state before the pause. For detailed parameters of the program control (PLC), see the multi-speed and PLC function "F12" group parameters.

31: Program operation (PLC) restart

When the frequency reference main channel selection [F00.03] is set to "9: Program control (PLC) reference", the signal is valid to restart the program during the stop status and program operation, from the first The phase begins to run. For detailed parameters of the program control (PLC), see the multi-speed and PLC function "F12" group parameters.

32: Acceleration/deceleration time selection terminal 1

33: Acceleration/deceleration time selection terminal 2

The acceleration/deceleration time selects the command input port, and the coding combination realizes the selection of the 4-stage acceleration/deceleration. When the parameter is not set and the terminal is invalid, the default selection is that the acceleration/deceleration time 1 is valid. See the detailed description of the parameters [F01.21~F01.26] for details.

34: Acceleration/deceleration pause In the inverter running state, when the terminal is valid, the inverter stops acceleration and deceleration and keeps the current speed unchanged.

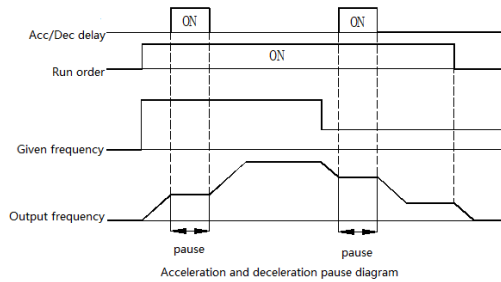
**35: Swing frequency input**

In the swing frequency control, if it is set to manual input, when the terminal is valid, the swing frequency function is valid and the inverter starts the swing frequency operation. See parameter [F12.49-F12.55] for details.

36: swing frequency pause

During the swing frequency control, when the terminal is valid, the inverter keeps the current output frequency unchanged. After the terminal command is cancelled, the swing frequency operation is resumed. See parameter [F12.49-F12.55] for details.

37: swing frequency reset

During swing frequency control, when the terminal generates a valid edge delay (invalid to active state), the inverter first returns to the center frequency and then re-enters the swing frequency operation. See parameter [F12.49-F12.55] for details.

38: keyboard self-test

When the input port is valid, the keyboard enters the self-test interface.

39: Frequency selection

The X10 terminal on the control board or the X10 terminal on the expansion card is changed to a high-speed pulse port as a PUL input port.

40: Timer trigger terminal

The port is that starts the timer to start the timer operation, and triggers the timing when the terminal is valid. See parameter [F02.37-F02.38] for details.

41: Timer clear terminal

The timing record of the timer is cleared when the terminal is valid. See parameter [F02.37-F02.38] for details.

42: Counter clock input terminal

For the clock input terminal of the counter function, see parameter [F02.39-F02.40].

43: Counter clear terminal

When the terminal is valid, clear the counter record of the counter. For details, see parameter [F02.39-F02.40].

44: DC braking command

When the inverter is stopped, the DC braking function of the inverter can be started. For the current during DC braking, refer to the setting value of the DC braking current for the stop [F01.12]. If a run or jog command is input, the

DC brake will be released.

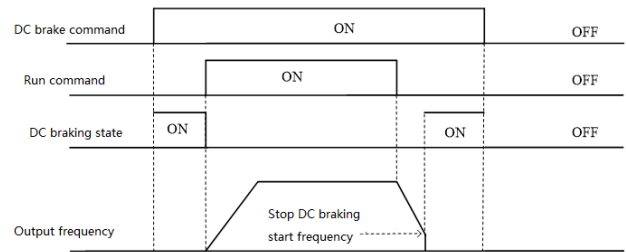

DC braking command diagram

45: Pre-excitation command terminal

This function is only valid during asynchronous machine vector control. When the inverter is stopped, the pre-excitation function of the inverter can be started. If a run or jog command is input, the pre-excitation will be released.

46-47: Reserved**48: Command channel switches to keyboard****49: Command channel is switched to the terminal****50: Command channel switches to communication****51: Command channel switch to expansion card**

The command channel switching terminal can be switched to 4 kinds of command settings. The effective priority of the terminal is keyboard, terminal, communication, and expansion card from high to low.

52: Run prohibition**53: Forward transfer prohibition****54: Reverse prohibition**

When the operation prohibition terminal selection is valid, the running command in the stop state is invalid, and the running state is free to stop;

When the forward rotation prohibition terminal selection is valid, the forward rotation running command is invalid in the stop state, and the free running is stopped in the forward running state;

When the reverse prohibition terminal selection is valid, the reverse running command is invalid in the stop state, and the free running is stopped in the reverse running state;

55-59: Reserved**60: Speed torque control switching**

This function is valid under vector control. When the terminal is valid, the motor is switched from speed control to torque control.

61: Position control switching

This function is valid only under closed loop vector control. When the terminal is valid, the motor control mode is switched to the position control mode; the effective priority of the terminal is greater than the speed torque control switching.

62-63: Reserved

F02.10	X1~X4 terminal trait selection	Setting range: 0000~1111	Default: 0000
--------	--------------------------------	--------------------------	---------------

X1 to X4 terminal characteristic selection: The characteristics of the multi-function input terminals X1, X2, X3, and X4 are set separately.

LED "0" digit: X1 terminal

LED "00" digit: X2 terminal

LED "000" digit: X3 Terminal

LED "0000" digit: X4 Terminal

0: Closed valid

1: disconnection is valid

F02.11	X5~X8 terminal trait selection	Setting range: 0000~1111	Default: 0000
F02.12	X9~X10 terminal trait selection	Setting range: 0000~1111	Default: 0000

The terminal characteristics are selected as above.

F02.13	X1 valid detection delay	Setting range: 0.000~6.000s	Default: 0.010
F02.14	X1 invalid detection delay	Setting range: 0.000~6.000s	Default: 0.010
F02.15	X2 valid detection delay	Setting range: 0.000~6.000s	Default: 0.010
F02.16	X2 invalid detection delay	Setting range: 0.000~6.000s	Default: 0.010
F02.17	X3 valid detection delay	Setting range: 0.000~6.000s	Default: 0.010
F02.18	X3 invalid detection delay	Setting range: 0.000~6.000s	Default: 0.010
F02.19	X4 valid detection delay	Setting range: 0.000~6.000s	Default: 0.010
F02.20	X4 invalid detection delay	Setting range: 0.000~6.000s	Default: 0.010
F02.21	X5 valid detection delay	Setting range: 0.000~6.000s	Default: 0.010
F02.22	X5 invalid detection delay	Setting range: 0.000~6.000s	Default: 0.010

Valid detection delay: The delay time corresponding to the input terminal X1~X5 transitioning from the invalid state to the active state.

Invalid detection delay: The delay time corresponding to the input terminal X1~X5 transitioning from the active state to the inactive state.

F02.23	Terminal control running mode	Setting range: 0~3	Default: 0
--------	-------------------------------	--------------------	------------

This parameter defines four different ways to control the operation of the drive via external terminals.

0: Two-wire control

The operation is in one direction. This mode is the most commonly used two-wire mode. The factory default is to determine the forward and reverse running of the motor by the X1 (forward running) and X2 (reverse running) terminal commands. As shown below:

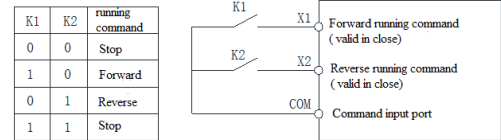

0: Two-wire control 1 schematic

1: Two-wire control 2:

The operation is separated from the direction. The forward running terminal X1 (forward running) defined in this mode is the operation enable terminal. The definition of the direction is determined by the state of the reverse running terminal X2 (reverse running). As shown below:

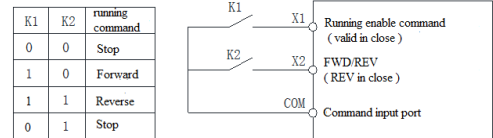

1: Two-wire control 2 schematic

2: Three-wire control 1:

In this mode, the three-wire operation control terminal (Xi) is the stop operation terminal, and the running command is generated by the forward rotation operation terminal X1 (forward rotation operation), and the direction is controlled by the reverse rotation operation terminal X2 (reverse rotation operation). The three-wire operation control terminal (Xi) is an effective input.

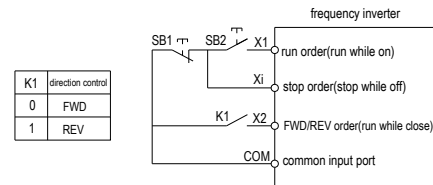

2: 3-line 1

2: Three-wire control 1 schematic

3: Three-wire control 2:

In this mode, the three-wire operation control terminal (Xi) is the stop operation terminal, and the operation command is generated by the forward rotation operation terminal X1 (forward rotation operation) or the reverse operation terminal X2 (reverse rotation operation), and both control the running direction.

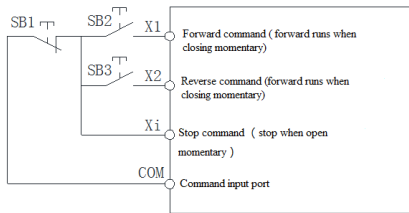

3. Three-wire control 2 schematic

Tips: SB1: Stop button; SB2: Forward run button; SB3: Reverse run button; "Xi" is multi-function input terminal set to "3" [3-wire operation control (Xi)].

F02.24	Terminal operate protection	Setting range: 0000 ~ 0111	Default: 0111
--------	-----------------------------	----------------------------	---------------

Terminal start protection:

An abnormality in the inverter causes a shutdown and protects the validity of the terminal command. When the abnormality disappears, the terminal signal does not change before the abnormality occurs. At this time, if the protection is turned off, the inverter considers that the terminal command continues to be valid and runs according to the given command; if the protection is turned on, the inverter considers that the terminal command is invalid, and must first The terminal command is undone before it can respond to the new terminal command.

The protection terminal includes: a start command terminal, a jog terminal, and a command channel switch terminal.

Abnormal conditions include: fault, undervoltage, or external abnormal shutdown commands.

LED "0" digit: terminal start protection when exiting abnormal

- 0: off
- 1: open

The above status is valid only when the terminal control operation [F00.02] is set to "1" and is in the two-wire control mode, that is, when [F02.23] is set to "0" or "1". In the three-wire control mode, the run command must be re-entered.

LED "00" digit: Jog terminal start protection when exiting abnormal

- 0: off
- 1: open

LED "000" digit: Start protection when the command channel is switched to the terminal

- 0: off
- 1: open

LED "0000" digit: Reserved

Note:

1. When the start/stop command channel is terminal and the control mode is two-wire type, the terminal running command will be abnormally stopped when the terminal running command is continuously valid. When the abnormality disappears, if the protection is turned off, the inverter will immediately start the motor to enter the running state; if the protection is turned on, the previous running command must be cancelled before the motor can be started in response to the new running command.

F02.25	Counter input	0: Common X terminal 1: High speed input terminal PUL	2: PG card counting	Default: 0
F02.26	Count input frequency division	0-6000		Default: 0
F02.27	PUL signal source	0: X5(max~5 KHz) 1: Extend interface X10(max~100 KHz) 2: Reserved	Default: 0	
F02.28	PUL input min frequency	Setting range: 0.00 ~ 50.00kHz		Default: 0.00kHz
F02.29	PUL min frequency corresponding setting	Setting range: 0.00 ~ 100.00%		Default: 0.00%
F02.30	PUL input max frequency	Setting range: 0.00 ~ 100.00kHz		Default: 100.00kHz
F02.31	PUL max frequency corresponding setting	Setting range: 0.00 ~ 100.00%		Default: 100.00%
F02.32	PUL filter time	Setting range: 0.000 ~ 9.000s		Default: 0.100s
F02.33	PUL cut-off frequency	Setting range: 0.000 ~ 1.000kHz		Default: 0.010kHz

PUL input minimum frequency:

This function defines the minimum frequency accepted by the pulse input terminal (PUL). Below this frequency signal, the drive will process at the input minimum frequency.

PUL minimum frequency corresponding setting:

Used to set the percentage of the set value corresponding to the PUL minimum input frequency.

PUL input maximum frequency:

This function defines the maximum frequency accepted by the pulse input terminal (PUL). Above this frequency signal, the inverter will process at the input maximum frequency.

PUL maximum frequency corresponding setting:

It is used to set the percentage of the set value corresponding to the maximum input frequency of PUL.

PUL filter time:

This parameter is defined as the size of the input pulse signal to filter out the interference signal. The longer the

filtering time, the stronger the anti-interference ability, but the reaction speed becomes slower; the shorter the filtering time, the weaker the anti-interference ability, but the reaction speed becomes faster.

PUL cutoff frequency:

This parameter defines the minimum recognition pulse frequency of the PUL port. Below the pulse frequency of this parameter, the inverter no longer recognizes it and processes it according to the "0Hz" frequency value. The smaller the value is set, the lower the pulse frequency that the PUL port can receive. However, when the PUL port pulse frequency disappears, the inverter determines that the pulse input is "0 Hz" for a longer period of time.

F02.34	UP/DW terminal control mode	Setting range: 0~2	Default: 0
F02.35	ACC/DEC speed of UP/DW terminal frequency control	Setting range: 0.01~50.00Hz/s	Default: 0.50Hz/s
F02.36	Reserved		

Terminal UP/DW control mode:

0: Power-down shutdown storage When the terminal UP/DW is adjusted, the frequency record is maintained after the machine is powered off or stopped. During power-on operation, the inverter performs UP/DW adjustment operation from the frequency at the last stop.

1: Don't save when unenergized and save when stopping When the terminal UP/DW is adjusted, the frequency record is maintained after the machine stops. During the next run, the inverter performs UP/DW adjustment operation from the frequency at the last stop. Recording is not saved after power failure, starting from 0.00Hz.

2: Valid when running and clear when stopping When the terminal UP/DW is adjusted, the frequency record is not maintained after the machine stops or powers off. During the next run, the inverter performs UP/DW regulation operation from a frequency of 0.00 Hz.

Terminal UP/DW controls the frequency increase and decrease rate:

This function defines the rate of change of a given frequency when the terminal UP/DW is adjusted.

F02.37	Timer time unit	Setting range: 0~2	Default: 0
F02.38	Timer setting value	Setting range: 0~65000	Default: 0

Timer time unit:

This function is used to set the timing unit of the inverter timer.

0: Second The timer is timed in seconds.

1: Minute The timer is timed in minutes.

2: Hour The timer is timed in hours.

Timer setting:

This parameter is used to set the timing of the inverter. The timer starts counting when the external trigger terminal receives the valid signal, and after the timing time arrives, the pulse signal with a width of 1 second is output from the corresponding output terminal.

The trigger terminal is determined by the multi-function input terminal selection "40: Timer Trigger Terminal". See [F02.00~F02.12] for details.

The output terminal is determined by the multi-function output terminal selecting "21: Timer time to". See [F02.43~F02.50] for details.

When the trigger terminal is invalid, the timer keeps the existing timing value, and the accumulated timing continues after the trigger terminal is valid.

The timer clear terminal can clear the timing value at any time.

Tip: The timer can work independently, not limited by the running status of the inverter. When some working conditions require timing, the inverter can be used. The timer, in which the timing time can be displayed in [C00.30], the time unit is determined by [F02.37].

F02.39	Counter max value	Setting range: 0~65000	Default: 1000
F02.40	Counter setting value	Setting range: 0~65000	Default: 500
F02.41	Reserved		

This parameter specifies the counting action of the internal counter and counts the clock type signal of the counter input terminal.

Counter maximum:

When the count value reaches the value specified by parameter [F02.39], the corresponding output terminal outputs a valid signal. The output signal width is equal to the clock period of the valid signal of the external input terminal, that is, when the next count signal is input, the output terminal stops outputting the valid signal.

The input terminal is determined by the multi-function input terminal selection "42: Counter input terminal". See [F02.00~F02.12] for details.

The output terminal is determined by the multi-function output terminal selecting "22: Counter reaches maximum value". See [F02.43~F02.50] for details.

Counter setting:

When the count value reaches the value specified by the parameter [F02.40], the valid signal is output at the corresponding output terminal, and the output signal width is the value of the count value exceeding the value specified by the parameter [F02.39], causing the output terminal to be cleared when the counter is cleared. The output of the valid signal is stopped.

The input terminal is determined by the multi-function input terminal selection "42: Counter input terminal". See [F02.00~F02.12] for details.

The output terminal is determined by the multi-function output terminal selecting "23: Counter reaches the set value". See [F02.43~F02.50] for details.

The count value of the counter can be cleared at any time by the counter clear terminal set by the multi-function input terminal [F02.00~2.09].

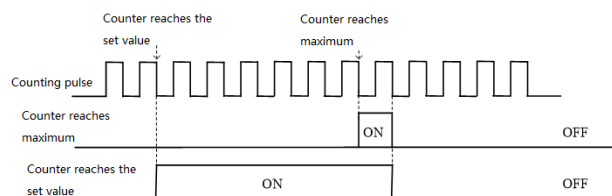

Counter maximum value and counter setting value related operation diagram

Notes: The counter can work independently and is not limited by the running status of the inverter. When some working conditions need to be counted, the counter in the inverter can be used, and the counting value can be displayed in [C00.22].

F02.42	Output terminal polarity selection	Setting range: 0000~0111	Default: 0000
--------	------------------------------------	--------------------------	---------------

LED "0" digit: Y terminal

- 0: Positive polarity - active state Y output terminal low level, equivalent normally open
- 1: Negative polarity - active state Y output terminal has no output, equivalent normally open

LED "00" digit: relay output terminal 1

- 0: Positive polarity TA-TC normally open TB-TC normally closed
- 1: Negative polarity TA-TC normally closed TB-TC normally open

LED "000" digit: relay output terminal 2

- 0: Positive polarity TA1-TC1 normally open TB1-TC1 normally closed
- 1: Negative polarity TA1-TC1 normally closed TB1-TC1 normally open

LED "0000" digit: Reserved

F02.43	Output terminal Y1	Setting range: 0~31	Default: 1
F02.44	Relay output		Default: 4
F02.45	Extend terminal Y1		Default: 11
F02.46	Extend relay output 2		Default: 11

Output terminal Y and relay function selection**0: no output**

Indicates that the terminal is invalid. If the terminal function is idle, it is recommended to set it to "0" to prevent malfunction.

1: The inverter is running

A valid signal is output when the inverter is in operation.

2: The inverter is running in reverse

When the inverter is in the reverse running state, a valid signal is output.

3: The inverter is running in forward

When the inverter is in forward running state, it outputs a valid signal.

4: Fault trip alarm 1 (alarm during fault self-recovery)

When the inverter is faulty, including the fault self-recovery period, the output signal.

5: Fault trip alarm 2 (no alarm during self-recovery)

When the inverter is faulty, it does not include the fault self-recovery period and outputs a valid signal.

6: External downtime

When the multi-function input terminal inputs an external fault signal and reports the external fault E, EF of the inverter, it outputs a valid signal.

7: Inverter undervoltage

A valid signal is output when the frequency converter is under voltage.

8: The inverter is ready for operation

When the signal is valid, it means that the inverter has no fault, the bus voltage is normal, the operation prohibition terminal such as emergency stop or emergency stop of the inverter is invalid, and it can be operated after accepting the start command.

9: Output frequency level detection 1 (FDT1)**10: Output frequency level detection 2 (FDT2)**

When the output frequency of the inverter exceeds the frequency detection level [F02.51]/[F02.53] setting value, after the hysteresis frequency set by [F02.52]/[F02.54], the valid signal is output. When the output frequency of the inverter is lower than the frequency detection level, the invalid signal is output after the same hysteresis frequency. See the description of parameter [F02.51~F02.54] for details.

11: the given frequency arrives

When the output frequency of the inverter approaches or reaches a given frequency to a certain range (the range is determined by parameter [F02.55]), the valid signal is output, otherwise the invalid signal is output. See the description of parameter [F02.55] for details.

12: running at zero speed

When the inverter is running and the output is 0.00Hz, a valid signal is output.

13: The upper limit frequency arrives

When the inverter runs at the upper limit frequency, it outputs a valid signal.

14: Lower limit frequency arrival

When the inverter runs at the lower limit frequency, it outputs a valid signal.

15: Program running cycle completion When the program runs one cycle end, it outputs a valid signal of 500ms.**16: program running phase is completed**

When the program runs at the end of a phase, a valid signal of 500ms is output.

17: PID feedback exceeds the upper limit

When the PID feedback amount reaches the upper limit of the disconnection alarm [F11.27], the feedback signal is over-limit after the delay time of [F11.25], and the valid signal is output.

18: PID feedback is below the lower limit

When the PID feedback amount reaches the lower limit of the disconnection alarm [F11.28], the feedback signal is over-limit after the delay time of [F11.25], and the valid signal is output.

19: PID feedback sensor disconnected

When the PID feedback sensor is disconnected, a valid signal is output. See parameter [F11.25-F11.28].

20: Reserved

21: Timer time is up

When the inverter internal timer timing time arrives, the port outputs a valid pulse signal with a width of 1 second. See parameter [F02.37-F02.38].

22: Counter reaches the maximum value

When the counter reaches the maximum value, the output terminal outputs a valid signal with a width equal to the external clock cycle, and the counter is cleared. See parameter [F02.39-F02.40].

23: Counter reaches the set value

When the counter reaches the set value, the output terminal outputs a valid signal, and continues to count until the counter exceeds the maximum value, causing the counter to be cleared, and the output valid signal is cancelled. See parameter [F02.39-F02.40].

24: Energy braking

When the inverter meets the energy consumption braking condition, it outputs a valid signal. See parameter [F04.29] for details.

25: PG feedback disconnection

When the PG feedback disconnection is detected, a valid signal is output. See parameter [F05.30-F05.32].

26: Emergency stop

When the inverter is in the emergency stop state, a valid signal is output.

27: Load pre-alarm output 1

28: Load pre-alarm output 2

When the inverter is running, in the VF control mode, the motor output current is used as the load warning judgment value; in the vector control mode, the motor output torque is used as the load warning judgment value, and the load warning judgment value is compared with the load warning detection level to determine whether Output a valid signal. See parameter [F10.17-F10.21].

29: Reserved

30: RS485 given

Set by RS485 communication (0x3018/0x2018), BIT0 bit corresponds to Y output, BIT1 corresponds to relay 1 output, and BIT2 bit corresponds to relay 2 output.

31: Reserved

32: Expansion card temperature reaches output

When the motor temperature detected by the expansion card reaches the set temperature detection value, a valid signal is output.

F02.47	Y output delay time	Setting range : 0.000 ~ 6.000s	Default : 0.010s
F02.48	Extend Y output delay output	Setting range : 0.000 ~ 6.000s	Default : 0.010s
F02.49	Relay 1 output delay time	Setting range : 0.000 ~ 6.000s	Default : 0.010s
F02.50	Extend relay 2 output delay time	Setting range : 0.000 ~ 6.000s	Default : 0.010s

When the internal logic operation of the inverter is to change the state of the Y terminal, the actual state of the Y

terminal is output after the set delay time. The delay time precautions are the same as the input terminals. The relay output terminals are the same.

F02.51	Output frequency level 1(FDT1)	Setting range: 0.00 ~ Maximum frequency	Default: 30.00Hz
F02.52	FDT1 lag	Setting range: 0.00 ~ Maximum frequency	Default: 1.00Hz
F02.53	Output frequency level 2(FDT2)	Setting range: 0.00 ~ Maximum frequency	Default: 50.00Hz
F02.54	FDT2 lag	Setting range: 0.00 ~ Maximum frequency	Default: 1.00Hz

During acceleration, when the output frequency of the inverter exceeds the frequency detection level [F02.51] / [F02.53] setting value, after the hysteresis frequency set by [F02.52]/[F02.54], the output is output. Valid signal; when decelerating, when the output frequency of the inverter is lower than the frequency detection level, after the same hysteresis frequency, the invalid signal is output. The output frequency is detected as shown below:

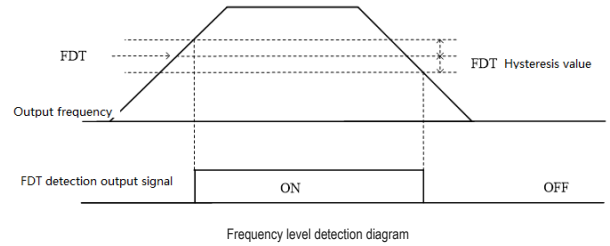

F02.55	Given frequency arriving checkout range	Setting range : 0.00 ~ 50.00Hz	Default : 2.00Hz
--------	---	--------------------------------	------------------

When the output frequency of the inverter reaches or approaches a given frequency value, the output terminal (Y/TA-TB-TC) is selected as the "given frequency arrival" output valid signal; this function can adjust the upper and lower deviation of its detection amplitude. Transfer amount. The frequency arrival output is shown below:

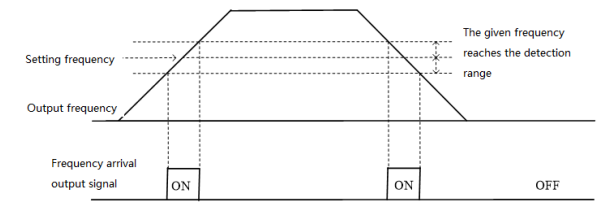

Frequency arrival detection diagram

F02.55- F02.59	Reserved
----------------	----------

F02.60	Virtual vX1 terminal function selection	Setting range: 0~63	Default: 0
F02.61	Virtual vX2 terminal function selection		
F02.62	Virtual vX3 terminal function selection		
F02.63	Virtual vX4 terminal function selection		

The virtual vX1 to vX4 are identical in function to the multi-function input terminals X1 to X10 and can be used as multi-function digital input. For detailed setting of terminal functions, please refer to [F02.00-F02.09].

F02.64	vX terminal valid state source	Setting range : 0000 ~ 1111	Default : 0000
--------	--------------------------------	-----------------------------	----------------

LED "0" digit: virtual vX1

- 0: Internal connection with virtual vY1
- 1: Link to physical terminal X1
- 2: Is the function code setting valid?

LED "00" digit: virtual vX2

- 0: Internal connection with virtual vY2
- 1: Link to physical terminal X2
- 2: Is the function code setting valid?

LED "000" digit: Virtual vX3

- 0: Internal connection with virtual vY3
- 1: Link to physical terminal X3
- 2: Is the function code setting valid?

LED "0000" digit: Virtual vX4

- 0: Internal connection with virtual vY4
- 1: Link to physical terminal X4
- 2: Is the function code setting valid?

The input status of the virtual vX1~vX4 terminals can be set in three ways, which is selected by [F02.64]:

When the state of vX1 to vX4 is connected to the internal connection of virtual vY1 to vY4, whether vX1 to vX4 are valid, depending on whether the output of vY1 to vY4 is valid or invalid, and vX1-vY1; vX2-vY2; vX3-vY3; vX4- vY4 is a one-to-one binding relationship.

When the state of vX1 to vX4 is selected and the physical terminals X1 to X4 are linked, whether vX1 to vX4 are valid or not depends on whether the X1 to X4 inputs are valid or invalid.

When the state of vX1 to vX4 is selected by the function code, whether vX1 to vX4 are valid, the status of the corresponding input terminal can be set by function code [F02.65].

F02.65	Virtual vX terminal function code setting valid state	Setting range : 0000 ~ 1111	Default : 0000
--------	---	-----------------------------	----------------

LED "0" digit: virtual vX1

- 0: invalid;
- 1: valid

LED "00" digit: virtual vX2

- 0: invalid;
- 1: valid

LED "000" digit: Virtual vX3

- 0: invalid;
- 1: valid

LED "0000" digit: Virtual vX4

- 0: invalid;
- 1: valid

F02.66	Virtual vY1 terminal function selection	Setting range: 0~31	Default: 0
F02.67	Virtual vY2 terminal function selection		
F02.68	Virtual vY3 terminal function selection		
F02.69	Virtual vY4 terminal function selection		

The virtual terminal vY1~vY4 output function selection is the same as the Y terminal and relay. For details, please refer to [F02.43-F02.46].

F02.70	vY1 output delay	Setting range : 0.000 ~ 6.000s	Default : 0.010s
F02.71	vY2 output delay	Setting range : 0.000 ~ 6.000s	Default : 0.010s
F02.72	vY3 output delay	Setting range : 0.000 ~ 6.000s	Default : 0.010s
F02.73	Virtual vY2 output selection	Setting range : 0.000 ~ 6.000s	Default : 0.010s

The virtual terminal vY1~vY4 output delay setting is the same as the Y terminal and relay delay. For details, please refer to [F02.47-F02.50].

The virtual terminal is characterized by the combination of vXi and vYi. When you want to use the Y terminal output signal as the X terminal input signal, you can use the internal vXi and vYi virtual connection to achieve the purpose of use, thus saving the actual X and Y terminals for other Aspect use.

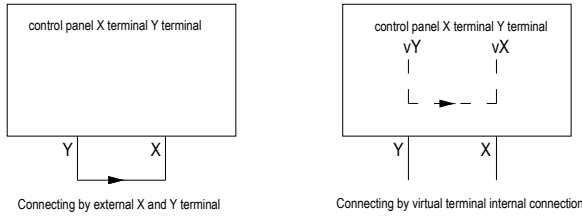

The following examples illustrate the application of virtual vX and vY:
 Example 1: In some cases, the inverter is required to run after power-on initialization. In general, an X terminal is used as input.

- If you use a virtual terminal, you can save this actual X terminal for other inputs, as follows:
- Set F00.02 = 1 to run the command source terminal control;
 - Set F02.23 = 0 two-wire control 1;
 - Set F02.60 = 1 terminal input to run in the forward direction;
 - Set F02.64 = 0000 The valid state of vX1 is determined by vY1;
 - Set F02.66 = 8 Output is output when the inverter is ready for operation.

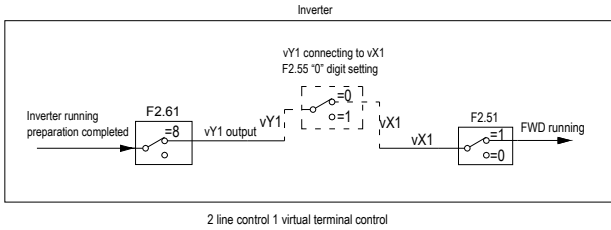

- Example 2: After the inverter is powered on, the delay is 60s forward running, as follows:
- Set F00.02 = 1 to run the command source terminal control, F02.23 = 2 three-wire control 1;
 - Set F02.38 = 60 timer timer 60s;
 - Set F02.60 = 1 vX1 terminal function input, forward running;
 - Set F02.61 = 3 vX2 terminal function input, three-wire operation control (X1);
 - Set F02.62 = 40 vX3 terminal function input, timer trigger;
 - Set F02.64 = 0110 vX2 and vX3 valid status source is determined by F02.64 ten or hundred;
 - Set F02.65 = 0110 vX2, vX3 setting is valid;
 - Set F02.66 = 21 The vY1 timer counts up to the output.

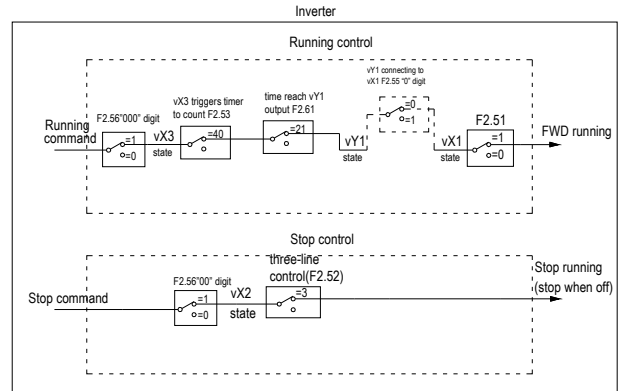

Notes: It can be seen from the above figure that the actual method requires access to two actual external X terminals. If virtual terminals are used, no external actual terminals need to be connected.

8.4 Analog Terminal Parameters

F03.00	AI1 Lower limit	Setting range: 0.00~10.00V	Default: 0.00V
F03.01	AI1 Lower limit corresponding setting	Setting range: -100.00~100.00%	Default: 0.00%
F03.02	AI1 upper limit	Setting range: 0.00~10.00V	Default: 10.00V
F03.03	AI1 upper limit corresponding setting	Setting range: -100.00~100.00%	Default: 100.00%
F03.04	AI1 filter time	Setting range: 0.00~6.000s	Default: 0.100s
F03.05	Reserved		

Analog type The voltage or current input can be selected via the on-board switch. See Section 3.6 Switching Function Description for Electrical Installation.

AI1 lower limit:

This function defines the signal accepted by the analog input terminal (AI1). If the voltage signal is lower than this value, the inverter will process according to the lower limit of AI1.

The AI1 lower limit corresponds to the setting:

It is used to set the percentage of the set value corresponding to the AI1 lower limit input analog quantity.

AI1 upper limit:

This function defines the signal accepted by the analog input terminal (AI1). If the voltage signal exceeds this value,

the inverter will process according to the upper limit of AI1.

The AI1 upper limit corresponds setting:

It is used to set the percentage of the set value corresponding to the AI1 upper limit input analog quantity.

AI1 filtering time:

This parameter is defined as the size of the (AI1) input analog signal to filter out the interference signal. The longer the filtering time, the stronger the anti-interference ability, but the reaction speed becomes slower; the shorter the filtering time, the weaker the anti-interference ability, but the reaction speed becomes faster.

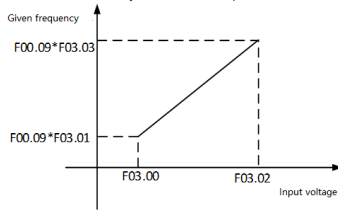

Tips: Set the frequency source to select AI1 timing, the set frequency can be adjusted to a negative value, and the [F00.16] hundred-bit selection frequency control direction can be matched to perform bipolar adjustment.

F03.06	AI2 Lower limit	Setting range: 0.00~10.00V	Default: 0.00V
F03.07	AI2 Lower limit corresponding setting	Setting range: -100.00~100.00%	Default: 0.00%
F03.08	AI2 upper limit	Setting range: 0.00~10.00V	Default: 10.00V
F03.09	AI2 upper limit corresponding setting	Setting range: -100.00~100.00%	Default: 100.00%
F03.10	AI2 filter time	Setting range: 0.00~10.00s	Default: 0.100s
F03.11	Reserved		

See the description of AI1.

F03.12	AI1 function selection	Setting range: 0~63	Default: 0
F03.13	AI1 high level setting	0.00~100.00%	70.00%
F03.14	AI1 low level setting	0.00~100.00%	30.00%
F03.15	AI2 function selection	Setting range: 0~63	Default: 0
F03.16	AI2 high level setting	0.00~100.00%	70.00%
F03.17	AI2 low level setting	0.00~100.00%	30.00%

The function selection of AI1 and AI2 terminals is the same as the multi-function input X1~X10 on the control panel. It can be used as a multi-function digital input. For detailed settings, please refer to [F02.00~F02.09].

AI1, AI2 high level setting: The port sampling value is considered to be high level if it is greater than or equal to the set value.

AI1, AI2 low level setting: The port sampling value is considered to be low level if it is less than or equal to the set value.

The AI1 port sampling filter value is adjusted by the curve, 0.00~10.00V corresponds to 0~100.00%

The AI1 port sampling filter value is adjusted by the curve, 0.00~20.00 MA corresponds to 0~100.00%

If AI is used as voltage input, 0.00~10.00V corresponds to 0~100.00%.

If AI is used as current input, 0.00~20.00 MA corresponds to 0~100.00%

F03.18	Valid state setting when analog used as terminal	Setting range: 0000~0011	Default: 0000
--------	--	--------------------------	---------------

LED "0" digit: AI1

0: low level

1: high level

LED "00" digit: AI2

0: low level

1: high level

LED "000" digit: Reserved

LED "0000" digit: Reserved

F03.19	Analog input curve selection	Setting range: 0000~0222	Default: 0000
--------	------------------------------	--------------------------	---------------

LED "0" digit: AI1

LED "00" digit: AI2 (selectable voltage or current input via switch on the control board)

0: **Straight line** By default, the usual two-point line can be referred to the "analog given frequency diagram" above.

1: **Curve 1 Multi-point stitching** please see the description of function code [F03.21~F03.28].

2: **Curve 2 Multi-point stitching** please see the description of function code [F03.29~F03.36].

F03.21	Curve 1 lower limit	Setting range: 0.00~10.00V	Default: 0.00V
F03.22	Curve 1 lower limit corresponding setting	Setting range: 0.00~100.00%	Default: 0.00%
F03.23	Curve 1 inflection point 1 input voltage	Setting range: 0.00~10.00V	Default: 3.00V
F03.24	Curve 1 inflection point 1 corresponding setting	Setting range: 0.00~100.00%	Default: 30.00%
F03.25	Curve 1 inflection point 2 input voltage	Setting range: 0.00~10.00V	Default: 6.00V
F03.26	Curve 1 inflection point 2 corresponding setting	Setting range: 0.00~100.00%	Default: 60.00%
F03.27	Curve 1 upper limit	Setting range: 0.00~10.00V	Default: 10.00V
F03.28	Curve 1 upper limit corresponding setting	Setting range: 0.00~100.00%	Default: 100.00%
F03.29	Curve 2 lower limit	Setting range: 0.00~10.00V	Default: 0.00V

F03.30	Curve 2 lower limit corresponding setting	Setting range: 0.00~100.00%	Default: 0.00%
F03.31	Curve 2 inflection point 1 input voltage	Setting range: 0.00~10.00V	Default: 3.00V
F03.32	Curve 2 inflection point 1 corresponding setting	Setting range: 0.00~100.00%	Default: 30.00%
F03.33	Curve 2 inflection point 2 input voltage	Setting range: 0.00~10.00V	Default: 6.00V
F03.34	Curve 2 inflection point 2 corresponding setting	Setting range: 0.00~100.00%	Default: 60.00%
F03.35	Curve 2 upper limit	Setting range: 0.00~10.00V	Default: 10.00V
F03.36	Curve 2 upper limit corresponding setting	Setting range: 0.00~100.00%	Default: 100.00%

Curve 1 and curve 2 can set two inflection points, which are divided into three straight lines. The slope of each segment can be different, which can achieve a more flexible correspondence, as shown in the following figure:

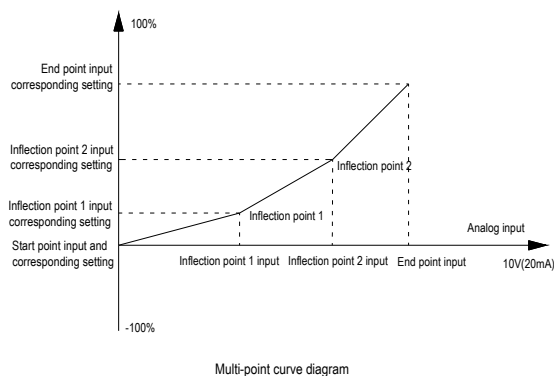

If AI1 or AI2 selects curve 1 or curve 2, the current is converted into voltage to set the current to twice the voltage. 4mA corresponds to 2V, and 20mA corresponds to 10V.

Notes: [F03.21, F03.23, F03.25, F03.27] and [F03.29, F03.31, F03.33, F03.35] voltage input values must be set incrementally.

F03.37	A0 output signal selection	Setting range: 0000~0032	Default: 0000
--------	----------------------------	--------------------------	---------------

LED "0" digit: AO1

- 0:0~10V
- 1:4.00~20.00mA
- 2: 0.00 to 20.00 mA

3: FM frequency pulse output

LED "00" digit: extended AO2

- 0:0~10V
- 1:4.00~20.00mA
- 2: 0.00 to 20.00 mA

Specify the output signal type of AO and extended AO2 terminals respectively, and select voltage output and current output; AO can also be used as pulse output. Extended AO2 is temporarily not supported.

Tip: After the parameter selection output mode, you need to toggle the corresponding DIP switch to achieve the corresponding output. For example, the AO output is the voltage. At this time, F03.37 is set to 0, and F03.38 is set to the corresponding monitoring amount. DIP switch AO-U can be turned ON. For example, the analog DIP switch diagram is described in section 3.6.

F03.38	A01 output selection	Setting range: 0~18	Default: 0
F03.39	A02 extended output selection		Default: 1

It is used to set the inverter monitoring quantity corresponding to the multi-output terminal (AO) and (AO2) output signals.

The signal type of the (AO) output is set by [F03.37] "0" digit.

The signal type of (AO2) output is set by [F03.38] "00" digit.

Set value	Monitoring amount	Function Description	AO minimum output	AO maximum output
0	Given frequency	Corresponds to the given frequency of the current inverter	The minimum output corresponds to 0.00Hz	Maximum output corresponds to maximum frequency
1	Output frequency	Corresponds to the output frequency of the current inverter	The minimum output corresponds to 0.00Hz	Maximum output corresponds to maximum frequency
2	Output current	Corresponds to the output current of the current inverter	The minimum output corresponds to 0.00A	The maximum output corresponds to 2 times the rated current of the inverter
3	Input voltage	Corresponds to the input voltage of the current inverter	The minimum output corresponds to 0V	The maximum output corresponds to 2 times the rated voltage of the inverter
4	Output voltage	Corresponding to the output voltage of the current inverter	The minimum output corresponds to 0V	The maximum output corresponds to the rated voltage of the inverter

5	Machine speed	Corresponding to the mechanical speed corresponding to the output frequency of the	The minimum output corresponds to 0rpm	The maximum output corresponds to the speed corresponding to the maximum frequency
6	Given torque	Corresponding to the output torque of the current inverter	The minimum output corresponds to a torque of 0.00%	The maximum output corresponds to 200% of the torque
7	Output torque	Corresponding to the output torque of the current inverter	The minimum output corresponds to a torque of 0.00%	The maximum output corresponds to 200% of the torque
8	PID given value	Corresponding to the PID given by the current inverter	The minimum output corresponds to 0.00% PID given	The maximum output corresponds to 100% PID given
9	PID feedback value	Corresponding to the PID feedback amount of the current inverter	The minimum output corresponds to 0.00% PID feedback	The maximum output corresponds to 100% of the PID feedback amount
10	Output power	Corresponds to the output power of the current inverter	The minimum output corresponds to 0 power	Maximum output corresponds to rated output power
11	Bus voltage	Corresponds to the input voltage of the current inverter	The minimum output corresponds to 0V	The maximum output corresponds to twice the rated DC voltage of the
12	AI1	Corresponds to the current AI1 input value of the inverter	The minimum output corresponds to the AI1 input lower limit	The maximum output corresponds to the upper limit of the AI1 input.
13	AI2	Corresponds to the current AI input value of the inverter	The minimum output corresponds to the AI input lower limit	The maximum output corresponds to the upper limit of the AI input.
14	AS input	Corresponds to the AS input value of the current inverter	The minimum output corresponds to the AS input lower limit	The maximum output corresponds to the upper limit of the AS input.
15	PULoutput value	Corresponds to the PUL input value of the current inverter	The minimum output corresponds to the PUL input lower limit	The maximum output corresponds to the upper limit of the PUL input.

16	Module temperature 1	Corresponds to the module temperature 1 of the current inverter	The minimum output corresponds to the module temperature 1 is 0 degrees Celsius	The maximum output corresponds to the module temperature 1 is 100 degrees Celsius
17	Module temperature 2	Corresponds to the module temperature 2 of the current inverter	The minimum output corresponds to the module temperature 2 is 0 degrees Celsius	The maximum output corresponds to module temperature 2 of 100 degrees Celsius
18	RS485 given	AO address 0x3019 /0x2019 AO2 address 0x301A /0x201A	Minimum output corresponds to 0	The maximum output corresponds to 1000

F03.40	A01 output gain	Setting range : 0.0~200.0%	Default : 100.0%
F03.41	A01 analog output signal bias	Setting range : -10.0~-10.0%	Default : 0.0%
F03.42	A01 output filter	Setting range : 0.000~6.000s	Default : 0.010s

AO output gain:

The value used to adjust the analog output of the (AO) terminal.

A0 output signal offset:

Used to adjust the zero point of the (AO) terminal output signal.

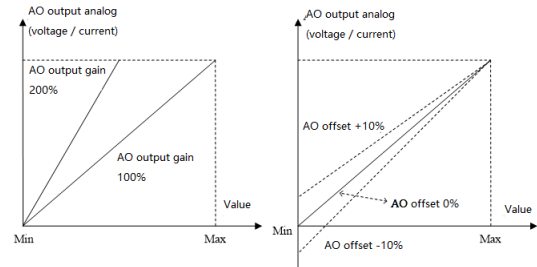

AO analog output and gain, offset schematic

A0 output filtering:

This parameter is defined as the size of the AO1 output analog signal filtered to eliminate the interference signal. The

longer the filtering time, the stronger the anti-interference ability, but the reaction speed becomes slower; the shorter the filtering time, the weaker the anti-interference ability, but the reaction speed becomes faster.

F03.43	A01 FM frequency output lower limit	Setting range: 0.00~100.00kHz	Default: 0.20kHz
F03.44	A02FM frequency output upper limit	Setting range: 0.00~100.00kHz	Default: 50.00kHz

Set the lower and upper frequency values of the output signal when AO is output at the FM frequency pulse.

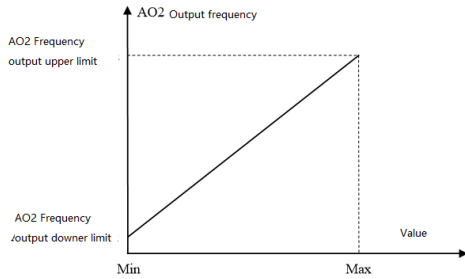

AO2 port pulse frequency output diagram

F03.45	A02 extend output gain	Setting range: 0.0~200.0%	Default: 100.0%
F03.46	A02 extend analog output signal bias	Setting range: -10.0~10.0%	Default: 0.0%
F03.47	A02 extend output filter	Setting range: 0.000~6.000s	Default: 0.010s

See the AO related parameter description.

8.5 Keyboard and Display Parameters

F04.00	Parameter and key lock selections	Setting range: 0~3	Default: 0
--------	-----------------------------------	--------------------	------------

0: not locked

The parameter and key lock function are invalid.

1: function parameter lock

The setting values of all function parameters are locked, and the parameters are prohibited from being modified (except F00.08, which can be modified by the up and down keys). The keyboard cannot enter the modification parameter interface, and the keyboard monitoring amount can be selected by the shift key.

All key functions on the keyboard are not locked.

2: Function parameters and key lock (except RUN/STOP).

The setting values of all function parameters are locked, and it is prohibited to modify the parameters (including F00.08, which cannot be modified by the up and down keys). The keyboard cannot enter the modification parameter interface, and the keyboard monitoring amount cannot be selected by the shift key.

Lock all keys on the keyboard except RUN/STOP.

3: Function parameters and button full lock

The setting values of all function parameters are locked, and the parameters are prohibited from being modified. The keyboard cannot enter the modification parameter interface, and the keyboard monitoring amount cannot be selected by the shift key.

Lock all keys on the keyboard except PRG.

Tips:

- **Double-line digital tube keyboard unlocking method:** Double-line digital tube keyboard After pressing the "PRG" menu button, the first line of the keyboard displays "CodE". You can use the up and down keys to enter the user password (F04.01 - user password) in the second line and then press the "SET" button to unlock.
- **Single-line digital tube keyboard unlocking method:** Single-line digital tube keyboard displays "CodE" after pressing "PRG" menu button. Then press the "SET" button to display the flashing input cursor. Enter the user password (F04.01—user password) through the up and down keys and press the "SET" button again to confirm.
- The user password is a protective parameter set by the customer to protect the inverter parameters arbitrarily tampering. After the password is set, the password should be properly kept in case it is inconvenient to modify the parameters later.

F04.01	User password	Setting range: 0~9999	Default: 0
--------	---------------	-----------------------	------------

Used to set the user password. When the parameter and key lock selection [F04.00] is locked (not "0"), you must enter the password to unlock. The factory default password is 0. Please keep the set password safe.

F04.02- F04.04	Reserved
----------------	----------

F04.05	Parameter copy	Setting range: 0~2	Default: 0
--------	----------------	--------------------	------------

Set the function parameter copy. After the copy is completed, the parameter will automatically change to "0".

0: no operation

1: The inverter parameter value is transmitted to the keyboard and saved The inverter F00 to F16 parameter group data is copied to the current operation keyboard and stored. At this point, the keyboard counts from 00 to 100 counts.

2: The parameter value saved by the keyboard is transferred to the inverter The data that has been copied in the current operating keyboard is downloaded to the inverter. At this point, the keyboard counts from 00 to 100 counts.

Notes:

- The single-line digital tube keyboard and the two-line digital tube keyboard memory are independent of each other, so the data saving and copying is subject to the currently operated keyboard.

- The parameter value saved by the keyboard cannot be transmitted to the inverter when the inverter is running or faulty or there is no parameter saved in the keyboard.
- When the inverter parameter value is transmitted to the keyboard and saved, if the keyboard cannot be copied after the keyboard is pulled out, the parameter copy operation needs to be performed again.
- When the parameter value saved on the keyboard is transmitted to the inverter, if the keyboard is pulled out, the previous part of the parameter modification will occur, and the latter part of the parameter is not modified, and the operation needs to be performed again.
- When the inverter parameter value is transmitted to the keyboard, the current running status of the inverter will not be maintained. When the parameter value saved by the keyboard is transmitted to the inverter, all the keys are invalid.
- Error in the parameter copy The keyboard displays E.COP (parameter copy exception). At this time, the copy is aborted and the parameter copy operation needs to be performed again. Press the PRG key to exit the E.COP display and return to the monitoring.
- When the software version is incompatible, it will prompt the error E.EDI, and the parameter value saved by the keyboard cannot be transmitted to the inverter.

F04.06	Keyboard special function selection	Setting range: 0000~1111	Default: 0000
--------	-------------------------------------	--------------------------	---------------

LED "0" digit: run command, stop/reset command

- 0: External priority, when the external is valid, the built-in is invalid.
- 1: Built-in priority, when the built-in is valid, the external is invalid
- 2: Both internal and external are valid, the stop/reset command takes precedence; when both forward and reverse are active, the command is invalid.

LED "00" digit: keyboard communication options

- 0: Both internal and external keyboards are valid
- 1: Only the built-in keyboard is valid
- 2: Only external keyboard is valid

LED "000" digit: LCD Keyboard Language Selection

- Set the LCD LCD keyboard display language, which is only effective when using the LCD LCD keyboard.
- 0: Chinese LCD LCD keyboard display content language is Chinese.
- 1: English LCD LCD keyboard display content language is English.

LED "0000" digit: Reserved

F04.07	Double-line keyboard REV/JOG selections	Setting range: 0-1	Factory set: 0
--------	---	--------------------	----------------

Used to select the function of REV/JOG key

- 0: REV**
While keyboard control, press this button, inverter reverse run. Key REV/JOG not light.
- 1: JOG**
While keyboard control, press this button, inverter JOG. Key REV/JOG light.

F04.08	STOP key function range	Setting range: 0-2	Factory set: 1
--------	-------------------------	--------------------	----------------

0: non keypad control is invalid While under non keypad control mode, the stop key in the keypad can not be used to stop.

1: non keypad control stop by stop mode While under non keypad control mode, the stop key in the keypad can be used as STOP key to stop.
It can be used as a stop button, and the stop mode is [F01.10] setting mode.

2: non keypad control free stop While under non keypad control mode, the stop key in the keypad can be used as STOP key to free stop.
It can be used as a stop button, the stop mode is free stop.

Note: While valid to terminal order or communication order, inverter is in stop lock state after press STOP key under terminal control or RS485 control. If inverter needs to restart, stop order needs to be given by selected order channel to unlock stop state firstly.

F04.09	UP/DOWN key modification selections	Setting range: 0000-0212	Factory set: 0011
--------	-------------------------------------	--------------------------	-------------------

LED "0" digit: keyboard UN/DOWN key modify selection

- 0: Invalid UP/DOWN key can not modify parameters.
- 1: Modify frequency setting by key board numbers (F0.08) UP/DOWN key can modify parameters [F0.08].
- 2: Modify PID given setting by key board numbers (F11.01) UP/DOWN key can modify parameters [F11.01].
- 3: Used to adjust the [F04.10] setting parameter [Fxx.yy] The keyboard up and down keys can quickly modify the setting value of the parameter [Fxx.yy].

LED "00" digit: keyboard UP/DOWN key store selection

- 0: No save after power down
 - 1: Save after power down
- It is used to select whether save the parameter modified by UP/DOWN key while power cut.

LED "000" digit: operation limit

- 0: Operation stop for adjusting
- 1: Adjusting only in operation, stop for holding
- 2: Adjusting in operation, stop for clearing

LED "0000" digit: reserved

F04.10	Keyboard up and down keys to quickly modify the parameter number setting Custom shortcut modification parameters	LED "00" digit: yy setting in Fxx.yy LED "000" and "0000" digits: xx setting in Fxx.yy For example: "0008" means F00.08 For example: "0009" means F00.09 For example: "1101" means F11.01	Factory set: 0008
F04.11- F04.13	Reserved		

Keyboard up and down keys quickly modify the parameter number setting:

LED "00" digit: used to specify the parameter number 00-99

LED "000" digit: used to specify parameter group number 00-15

F04.14	Keyboard display parameter 1	LED one digit ten: yy setting in monitoring code Cxx.yy LED hundred thousand digits: xx setting in monitoring code Cxx.yy For example: set "0000" to indicate that the monitoring code C00.00	Factory default: 0000
F04.15	Keyboard display parameter 2	Same as above	Factory default: 0001
F04.16	Keyboard display parameter 3	Same as above	Factory default: 0002
F04.17	Keyboard display parameter 4	Same as above	Factory default: 0011

Keyboard display parameters: used to set the contents of the single-line keyboard and double-line keyboard display parameters.

If F004.14 is set to 0000, the keyboard displays C00.00 given frequency.

Set to :0004 The display parameter is C00.04 (output voltage)

Set to :0011 and the display parameter is C00.11 (bus voltage)

Set to :0200 The display parameter is C02.00 (PID feedback)

Set to :0300 The display parameter is C02.00 (this power-on running time)

The single-line keyboard switches the keyboard display parameters 1-4 in sequence by long pressing the "SET" button (the two-line keyboard can be pressed through the "☐" button). Each time the button is pressed, one item is skipped and cycles between display parameters 1-4.

After the display content is switched, there is no power-off and memory function. After power-on, the content of "Display Parameter 1" is displayed by default.

Access 'C' parameter group by pressing 'PRG' for more than 2s; check the current state of VFD

C00-Basic Parameter Monitor Group

Function code	Function name	Unit and definition	Address
C00.00	Given frequency	0.01Hz	0x2100
C00.01	Output frequency	0.01Hz	0x2101
C00.02	Output current	0.1A	0x2102
C00.03	Input voltage	0.1V	0x2103
C00.04	Output voltage	0.1V	0x2104
C00.05	Machine speed	1RPM	0x2105

C00.06	Given torque	0.1%	0x2106
C00.07	Output torque	0.1%	0x2107
C00.08	PID given value	0.1%	0x2108
C00.09	PID feedback value	0.1%	0x2109
C00.10	Output power	0.1%	0x210A
C00.11	Bus voltage	0.1V	0x210B
C00.12	Module temperature 1	0.1 °C	0x210C
C00.13	Module temperature 2	0.1 °C	0x210D
C00.14	Input terminal X on state	See input terminal diagram	0x210E
C00.15	Output terminal Y on state	See output terminal diagram	0x210F
C00.16	Analog AI1 input value	0.001V/0.001mA	0x2110
C00.17	Analog AI2 input value	0.001V/0.001mA	0x2111
C00.18	Reserved		0x2112
C00.19	Pulse input value of PUL port	0.001kHz	0x2113
C00.20	Analog output AO1	0.01V/0.01mA/0.01kHz	0x2114
C00.21	Analog output AO2(extend)	0.01V/0.01mA/0.01kHz	0x2115
C00.22	Counting value of counter		0x2116
C00.23	Running time after power on	0.1 hour	0x2117
C00.24	Local accumulative running time	hour	0x2118
C00.25	VFD power level	kW	0x2119
C00.26	VFD rated voltage	V	0x211A
C00.27	VFD rated current	A	0x211B
C00.28	Software version		0x211C
C00.29	PG feedback frequency	0.01Hz	0x211D
C00.30	Counted time of timer	sec/min/hour	0x211E
C00.31	PID output value	0.00%	0x211F
C00.32	Software sub-version		0x2120
C00.33	Encoder angle	0.1°	0x2121
C00.34	Encoder deviation accumulative	1	0x2122
C00.35	Encoder Z signal pulse count	1	0x2123
C00.36	Fault pre alarm code	1	0x2124
C00.37	Total power consumption (low bit)	1°	0x2125
C00.38	Total power consumption (high bit)	10000°	0x2126
C00.39	Power factor angle	1°	0x2127

C01-Malfunction Diagnosis Monitor Group

Press the PRG button for 2 seconds or more to enter the "C00" parameter group and press the up button to enter the "C01" parameter group. Check the current status of the drive.

Function code	Function name	Unit and definition	Address
C01.00	Malfunction types	See fault code table	0x2200
C01.01	Malfunction diagnosis information	See fault code table	0x2201
C01.02	Malfunction running frequency	0.00~Max frequency	0x2202
C01.03	Malfunction output Voltage	0~1500V	0x2203
C01.04	Malfunction out Current	0.1~1000.0A	0x2204
C01.05	Malfunction Bus Voltage	0~3000V	0x2205
C01.06	Malfunction module temperature	0~100℃	0x2206
C01.07	Malfunction machine state	LED "0" digit: Running direction 0: FWD 1: REV LED "00" digit: Running status 0: Stop 1: ACC 2: DEC 3: Constant speed LED "000" and "0000" digit : Reserved	0x2207
C01.08	Malfunction input terminal status	See input terminal chart	0x2208
C01.09	Malfunction output terminal status	See output terminal chart	0x2209
C01.10	The last malfunction types	Please see malfunction code table	0x220A
C01.11	The first diagnosis information	Please see malfunction code table	0x220B
C01.12	The last malfunction running frequency	0.00~Maxfrequency	0x220C
C01.13	The last malfunction output voltage	0~1500V	0x220D
C01.14	The last malfunction output current	0.1~2000.0A	0x220E
C01.15	The last malfunction bus voltage	0~3000V	0x220F
C01.16	The last malfunction module temperature	0~100℃	0x2210
C01.17	The last malfunction machine state	LED "0" digit: Running direction 0: FWD 1: REV LED "00" digit: Running status 0: Stop 1: Constant speed 2: ACC 3: DEC LED "000" and "0000" digit : Reserved	0x2211
C01.18	The last malfunction input terminal state	See input terminal chart	0x2212
C01.19	The last malfunction output terminal state	See output terminal chart	0x2213
C01.20	The first two malfunction types	Please see malfunction information	0x2214
C01.21	The first two diagnosis information		0x2215

C01.22	The first three malfunction types	code table	0x2216
C01.23	The first three diagnosis information		0x2217

F04.18	Keyboard display parameter 5	Same as above	Factory set: 0002
F04.19	Keyboard display parameter 6	Same as above	Factory set: 0004
F04.20	Keyboard display parameter 7	Same as above	Factory set: 001
F04.21	Keyboard display parameter 8	Same as above	Factory set: 0012

It is valid only when the keyboard is double-lined, and is used to display the parameter selection on the second line of the keyboard. The two-line keyboard switches between the display parameters 5-8 of the second line of the keyboard by the "0" key.

For details, see the parameters [F04.14-F04.17].

F04.22	Keyboard display selections	Setting range: 0000-1111	Factory set: 0000
--------	-----------------------------	--------------------------	-------------------

LED "0" digit: output frequency selection

- 0: Aim frequency Display the aim frequency of current control motor
- 1: Actual frequency Display the output frequency of inverter

LED "00" digit: Reserved**LED "000" digit: Power display dimension** To correct the output frequency of C-10. Can select the unit of the power

- 0: Power display ratio (%) Display the ratio of output power, 100% corresponds with the rated motor power.
- 1: Power display Kilowatt (KW) Display the actual power

LED "0000" digit: reserved

F04.23	Monitor display selection	LED "0" digit: self-tuning display monitoring parameters 0: Invalid 1: Valid LED "00" digit: C05 group display selection 0-1: VF mode related parameters 2: VC mode related parameters LED "000" digit: C00.40-C00.69 display selection 0: Do not display 1: Display	Factory default: 0000
--------	---------------------------	--	-----------------------

F04.24	Rotate speed display coefficient	Setting range: 0.0-500.0%	Factory set: 100.0%
--------	----------------------------------	---------------------------	---------------------

It sets the display coefficient of keyboard monitor item "machine speed". 100% is corresponding to motor rated speed.

F04.25	Power display coefficient	Setting range: 0.0-500.0%	Factory set: 100.0%
--------	---------------------------	---------------------------	---------------------

This parameter sets the display coefficient ratio of the keyboard monitor item "output power"; for example, when the

output power is 10% of the rated motor, when F04.25 is set to 100.0%, C00.10 shows 10.0%; when 50.0% is set, C00.10 show 5.0%.

F04.26	Alarm selection 1	Setting range: 0000-0001	Factory set: 0
--------	-------------------	--------------------------	----------------

LED "0" digit: E.EEP fault (EEPROM store fault)

- 0: Alarm and free stop
- 1: Alarm and continue operation

LED "00" digit: reserved

LED "000" digit: reserved

LED "0000" digit: reserved

F04.27	Reserved		
--------	----------	--	--

F04.28	Fan control	Setting range: 0-2	Factory default: 1
--------	-------------	--------------------	--------------------

Select fan run mode:

0: Fan run after electrify No matter temperature of module is high or not, fan runs when inverter power on.

1: Fan stop related to temperature Work when running. When inverter stops, fan runs when module temperature is over 50 degree and stops 30 seconds after module temperature is lower than standard. When inverter runs, fan runs after 1s.

2: Fan stop when machine stop, run related to temperature When inverter runs, fan runs when module temperature is over 50 degree and stops 30seconds after module temperature is lower than standard. When inverter stops, fan stops after 30s.

Note: This function can prolong fan life.

F04.29	dynamic braking enabled	Setting range: 0~1	Factory default: 0
--------	-------------------------	--------------------	--------------------

Used for the motor dynamic braking enabled

0: OFF Inverter doesn't dynamic braking to control the motor, no matter the bus voltage.

1: Turn on the energy brake and turn off the overvoltage suppression. When the bus voltage exceeds the energy consumption braking action voltage, the inverter performs dynamic braking control on the motor, and the overvoltage suppression function is turned off at this time.

2: Enable energy braking and overvoltage suppression at the same time. When the bus voltage exceeds the energy consumption braking action voltage, the inverter performs dynamic braking control on the motor and turns on the overvoltage suppression function.

F04.30	dynamic braking operation voltage	Setting range: 115.0-140.0%	Factory default: 120.0%
--------	-----------------------------------	-----------------------------	-------------------------

dynamic braking operation voltage:

Inverter dynamic braking begins when DC bus voltage rises and exceeds **[F04.30]**. It is only valid for inverter with

inner braking parts. Inverters under AC200-T3-018G have build in braking parts. AC200-S2-3R7G and inverters under than that with 220V input have built-in braking parts. All inverters do not have braking resistance. If need dynamic braking, please use optional resistance.

Note: When use the dynamic braking function, please turn off the overvoltage suppression function, otherwise overvoltage suppression is possible to suppress the rise of the bus voltage, thus the brake operation point can't be reached.

F04.31	Reserved		
--------	----------	--	--

F04.32	PWM Carrier frequency	Setting range: 0.7-16.0kHz	Factory default: model set
--------	-----------------------	----------------------------	----------------------------

It is used to set IGBT frequency. Please set this parameter when adjusting electromagnetic noise and reducing leakage current. This feature is mainly used to improve noise and vibration during operation of the inverter. At higher carrier frequency of the current wave, the motor noise would be small. It is suitable for locations that need mute environment when run in high carrier frequency, but at the same time the main parts switch loss and the heat are heavy while the efficiency would be reduced. In the meantime, radio disturbance is heavy. And the other problem is that capacitance leak current would increase, and if there is leak protection, there may be mistake action or over current. When run in low carrier frequency, the case will be totally different.

Different motors would have different carrier frequency responses. The best carrier frequency comes with adjustment based on actual case. The bigger the capacity, the smaller the carrier frequency should be.

The Company reserves the right to limit maximum carrier frequency.

Carrier frequency	Motor noise	Electric disturbance	Radiator temperature
low	big	Small	low
↓	↓	↓	↓
high	small	big	high

Note: We advice ratio of carrier frequency to max frequency not lower than 36. If work under low frequency long time, we advice reduce carrier frequency to reduce the dead area time impact.

Cautions: when carrier frequency is higher than the factory default, the rated power would reduce 5% every time when carrier frequency adds 1 KHz.

F04.33	PWM control mode	Setting range: 0000-1111	Factory default: 1111
--------	------------------	--------------------------	-----------------------

LED "0" digit: carrier temperature associated settings

0: associated module temperature is invalid

1: associated module temperature is valid

When module temperature is too high, the frequency inverter reduces carrier frequency automatically, which can reduce switch loss and avoid frequent alarm for over heat.

LED "00" digit: associated settings of carrier output frequency

0: associated frequency output temperature is invalid

1: associated frequency output temperature is valid

When carrier frequency is related to frequency output, it can automatic adjust carrier frequency according to frequency output, which can improve the low frequency performance and high frequency mute effect.

LED "000" digit: random PWM valid

0: banned: Noise frequency is fixed.

1: valid: This mode allows the inverter output voltage harmonic spectrum evenly distributes over a wide frequency range, which can effectively suppress electrical noise and mechanical vibration.

LED "0000" digit: PWM modulation mode select PWM mode

0: Only use the three-phase modulation

1: Switch automatically between two phase and three phase modulation

8.6 Motor Parameters

F05.00	Motor selection	Setting range: 0-1	Factory set: 0
--------	-----------------	--------------------	----------------

Motor selection: Only read the parameter, indicating the current motor type. Decided by [F0.00] motor control mode.

0: Asynchronous motor (AM)

1: Synchronous motor (PM)

F05.01	Motor poles	Setting range: 2-98	Factory set: 4
--------	-------------	---------------------	----------------

Set the poles of the motor. Set it according to nameplate.

F05.02	Motor rated power	Setting range: 0.1-1000.0kW	Factory set: model set
--------	-------------------	-----------------------------	------------------------

Set it according to nameplate based on unit of 0.1kw. While motor rated power setting is changed, inverter will automatic adjust [F05.03-F05.11] to default. If self-tuning, [F05.07-F05.11] will automatic change according to the result of self study. If need high accuracy control, It must self study after right [F05.01-F05.06] setting.

F05.03	Motor rated frequency	Setting range: 0.01Hz-max frequency	Factory set: model set
--------	-----------------------	-------------------------------------	------------------------

Set it according to nameplate.

F05.04	Motor rated speed	Setting range: 1-6500rpm	Factory set: model set
--------	-------------------	--------------------------	------------------------

Set it according to nameplate.

F05.05	Motor rated voltage	Setting range: 1-1500V	Factory set: model set
--------	---------------------	------------------------	------------------------

Set it according to nameplate.

F05.06	Motor rated current	Setting range: 0.1-3000.0A	Factory set: model set
--------	---------------------	----------------------------	------------------------

Set it according to nameplate.

F05.07	Motor no-load current	Setting range: 0.01-650.00A	Factory set: model set
F05.08	Motor stator resistance	Setting range: 0.01-50.00%	Factory set: model set
F05.09	Motor rotor resistance	Setting range: 0.01-50.00%	Factory set: model set
F05.10	Motor stator&rotor inductance	Setting range: 0.01-50.00%	Factory set: model set
F05.11	Motor stator&rotor mutual inductance	Setting range: 0.1-2000.0%	Factory set: model set

Asynchronous motor model parameters.[F05.07-F05.11] will adjust automatically while set [F05.20] parameter self-tuning. No self-tuning if the accurate motor parameter is known, and then input the parameters manually.

F05.12	PMSM stator resistance	Setting range: 0.01-50.00%	Factory default: Model set
F05.13	PMSM d-axis inductance	Setting range: 0.01mH-400.00%	Factory default: Model set
F05.14	PMSM q-axis inductance	Setting range: 0.01mH-400.00%	Factory default: Model set
F05.15	PMSM back electromotive force	Setting range: 1V-1500V	Factory default: Model set

PMSM model parameters, of which the back electromotive force represents the voltage measured between lines when the motor rotor speed is set to the rated frequency speed; motor model parameters will automatically identify and modify in the motor parameter self-tuning. Wherein, [F05.15] will be recognized only in a rotating auto-tuning.

F05.16	PMSM encoder installation angle	Setting range: 0.0° -360.0°	Factory default: Model set
--------	---------------------------------	-----------------------------	----------------------------

When synchronous machines are running VC with PG (F0.00 = 7), this parameter is required to detect the magnetic pole position of the rotor. This parameter can be automatically identified and modified during the rotating auto-tuning, and generally it does not need adjustment.

F05.17-F05.19	Reserved		
---------------	----------	--	--

F05.20	Parameters self-adjustment selections	Setting range: 0-2	Factory set: 0
--------	---------------------------------------	--------------------	----------------

0: No operation Set as default without self study.

1: Rotary self-tuning Before self adjustment, [F05.01-F05.06] of asynchronous motor which is controlled must be set as right value. While self adjustment, firstly, asynchronous motor at static state, it automatic detects motor stator resistance, motor rotor resistance, motor stator&rotor inductance. Then the asynchronous motor at rotate state, it automatic detects motor no-load current, motor stator&rotor mutual inductance. All results will be auto wrote in the corresponding code and renewed while adjustment is over. After parameter setting, press FWD key to start self study,

keyboard LED display "1-01". Motor automatic stop while self adjustment is over. Inverter return to standby state.

2: Static self-tuning Before self adjustment, [F05.01-F05.06] of motor which is controlled must be set as right value.

While self adjustment, motor at static state, it automatic detects motor stator resistance, motor rotor resistance, motor stator&rotor inductance. All results will be auto wrote in the corresponding code and renewed while adjustment is over. After parameter setting, press FWD key to start self study, keyboard LED display "1-02". FWD indicator is off while self adjustment is over. Inverter return to standby state.

Note: [F05.20] is automatic set as 0 after self adjustment.

Cautions:

- Before setting [F05.20] to "1" for rotary self-tuning, the motor shaft should be removed from the load as much as possible, and the motor should be prohibited from carrying a heavy load for self-tuning of the rotation parameters. Otherwise, the inverter will report the learning failure. The lighter the learning load is, the better the learning accuracy will be. The asynchronous motor load is recommended not to exceed 30% of the rated load, and the synchronous motor is recommended not to exceed 20% of the rated load.
- In some occasions (such as when the motor cannot be disconnected from the load), it is not convenient to perform self-tuning in rotation type. For asynchronous motors, static learning can be used to learn the full parameters of the motor except the encoder parameters. If you run the closed-loop vector of the asynchronous motor, you need to manually input the encoder direction. For synchronous motors, the motor back EMF F05.15 should be set after the static learning is completed. If the control mode selects the closed loop vector, whether it is static learning or dynamic learning, the synchronous motor will rotate at a lower frequency for several weeks to learn the coding. Angle parameter.
- Since the motor parameters are displayed in the form of standard values, it is not recommended to manually input the motor parameters. In most cases, static learning can be run to run the open-loop vector. Under the control of v_f, learning the motor parameters will further optimize the automatic torque boost and slip. Compensation function.
- Before starting self-tuning, make sure that the motor is in a stopped state, otherwise self-tuning cannot be performed normally.
- When [F05.20] is set to "1", if overvoltage occurs during the self-tuning process and the overcurrent fault occurs, the acceleration/deceleration time can be extended appropriately [F00.14, F00.15].
- If the inverter self-tuning is unsuccessful, report E.TE1 failure.

F05.21	Synchronous machine poles searching function	Setting range: 0000-0012	Factory default: 0010
--------	--	--------------------------	-----------------------

LED "0" digit: closed-loop vector

- 0: OFF
- 1: ON
- 2: On, only operate firstly when electrify

LED "00" digit: open-loop vector

- 0: OFF
- 1: ON
- 2: ON, only operate firstly when electrify

While synchronous motor control is valid, the initial position of the motor rotor can be obtained when starting by the poles searching function. Under the closed-loop VC control, if the motor coder has not self-tuning the initial position, then the start initial position can be obtained by this function. Under open-loop control, obtaining the initial position guarantees the motor has a big force and no REV running while starting.

For synchronous closed-loop control using ABZ coder, the motor poles is unknown before detecting Z pulse. Hence, it is suggested to turn on the poles searching function to guarantee the stable start process and no REV running.

F05.22-F05.29	Reserved
---------------	----------

F05.30	Speed feedback or encoder type	Setting range: 0000-1111	Factory default: 0000
--------	--------------------------------	--------------------------	-----------------------

LED "0" digit: encoder type set encoder type according to the encoders actually selected.

- 0: Normal ABZ encoder
- 1: Rotary encoder

LED "00" digit: encoder direction When motor speed direction and encoder speed direction is inconsistent, switch direction by setting the parameter.

- 0: same direction;
- 1: opposite direction

LED "000" digit: disconnection detection when the break detection is turned on, the inverter would report encoder failure and stop when encoder disconnection is found.

- 0: OFF
- 1: ON

LED "0000" digit: Z pulse correction enabled

- 0: OFF
- 1: ON

F05.31	ABZ encoder lines	Setting range: 0-10000	Factory default: 1024
--------	-------------------	------------------------	-----------------------

ABZ encoder lines: used to set output pulse of speed feedback sensor every cycle; please set correctly according to the sensor specification.

F05.32	PG line-break detection time	Setting range: 0.100-60.000s	Factory default: 2.000s
--------	------------------------------	------------------------------	-------------------------

PG line-break detection time: used to confirm sensor disconnection delay time when the sensor break detection setting is valid; set 0sec as the off function of line-break detection.

F05.33	Rotary encoder poles	Setting range: 2-128	Factory default: 2
--------	----------------------	----------------------	--------------------

Rotary encoder poles: Set according to actual selection of rotary encoder, usually 2-pole resolver

F05.34	Encoder transmission ratio numerator	Setting range: 1~32767	Factory default:1
F05.35	Encoder transmission ratio denominator	Setting range: 1~32767	Factory default:1

If the motor encoder is not installed in the motor shaft, it could obtain the motor speed and position indirectly through the transmission setting to achieve closed-loop VC function. The premise is that the motor shaft and encoder is rigid connection. While under synchronous motor controls, the encoder lines converted to motor shaft could not be much less.

The gear ratio setting range should be controlled within the range of 100~0.01, otherwise the inverter will report an abnormal PG parameter error.

F05.36	First-order filter of encoder speed inspection	Setting range: 0.0-100.0ms	Factory default: 1.0ms
--------	--	----------------------------	------------------------

Promote the filter time properly if the motor encoder feedback noise is too big, but prolonging the filtering time will decrease system response performance. In some occasions with higher requirements on response performance, if the filter time is too long, it will lead to system oscillation.

F05.39	PG feedback monitoring selection	LED "0" digit: C00.29 monitor PG feedback speed. 0: invalid, 1: valid	Factory default: 0
--------	----------------------------------	---	--------------------

8.7 VC Control Parameter

F06.00	ASR proportional gain 1	Setting range: 0.01-100.00	Factory set: 10.00
F06.01	ASR integral time 1	Setting range: 0.000-6.000	Factory set: 0.500
F06.02	ASR filter time1	Setting range: 0.0-0.100.0ms	Factory set: 0.0ms
F06.03	ASR switch frequency 1	Setting range: 0.00-max frequency	Factory set: 0.00Hz
F06.04	ASR proportional gain 2	Setting range: 0.01-100.00	Factory set: 10.00
F06.05	ASR integral time 2	Setting range: 0.000-6.000	Factory set: 0.500
F06.06	ASR filter time 2	Setting range: 0.0-0.100.0ms	Factory set: 0.0ms
F06.07	ASR switch frequency 2	Setting range: 0.00-max frequency	Factory set: 5.00Hz

ASR proportional gain and ASR integral time adjustment: System response will be quicker by increase proportional gain. But if proportional gain is too big, there is surge easily. System response will be quicker by decreasing integral time. But if integral time is too short, there is surge easily. Usually, adjust proportional gain firstly, then adjust integral time.

Note: If ASR proportional gain is too big and ASR integral time is too small, over voltage maybe caused while system start to high speed quickly (without extra braking resistance or braking unit). It is caused by reborn energy feedback and can be avoided by adjust ASR proportional gain bigger and ASR integral time smaller.

ASR proportional gain and ASR integral time adjustment at high/low speed:

Set ASR switch frequency [F06.03] and [F06.07] while it has quick response requirement for load at high/low speed. Usually increase proportional gain and decrease integral time to improve response at low frequency running. Usually adjust as this: Set right [F06.03] and [F06.07]. The first group of ASR parameter is valid while output frequency is under switch frequency 1 [F06.04]. The second group of ASR parameter is valid while output frequency is between switch frequency 1 [F06.03] and switch frequency 2 [F06.07]. Parameter linearly transits from switch frequency 1 [F06.03] to switch frequency 2 [F06.07] pro rate. Adjust ASR proportional gain 2 [F06.04] and ASR integral time 2 [F06.05] at low speed to ensure no surge and good response. Adjust ASR proportional gain 1 [F06.00] and ASR integral time 1 [F06.01] at high speed to ensure no surge and good response. While the switch frequency 1 [F06.03] is set 0, just use the first group ASR parameter.

F06.08	Electric torque limit	Setting range: 0.0~400.0%	Factory default: 180.0%
F06.09	Power generation torque limit	Setting range: 0.0~400.0%	Factory default: 180.0%

Set the upper limit of the torque output of the motor. The percentage is relative to the rated torque of the motor. It is valid under the asynchronous machine, synchronous machine open loop and closed loop vector. The motor torque output is also limited by the inverter output current limit [F10.01] and output power [F06.27]. For details, please refer to the function code description.

F06.10	Current loop D-axis proportional gain	Setting range: 0.001~4.000	Factory default: 1.000
F06.11	Current loop D-axis integral gain	Setting range: 0.001~4.000	Factory default: 1.000
F06.12	Current loop Q-axis proportional gain	Setting range: 0.001~4.000	Factory default: 1.000
F06.13	Current loop Q-axis integral gain	Setting range: 0.001~4.000	Factory default: 1.000

Set the PI parameters of the current loop when the asynchronous machine and synchronous machine vector control. When vector control occurs, if speed, current oscillation, and instability occur, the gain can be appropriately reduced to achieve stability; at the same time, increasing the gain helps to improve the dynamic response of the motor.

F06.15	Vector control motor slip compensation	Setting range: 0.0-250.0%	Factory default: 100.0%
F06.16	Vector control generator slip compensation	Setting range: 0.0-250.0%	Factory default: 100.0%

The PM VC control is valid. While under open-loop VC control, the slip compensation coefficient is used to adjust the motor speed stabilization accuracy. When the motor speed is lower than the set value with load, the motor speed is increased, and vice versa.

While under closed loop VC control, this value is used to adjust the output torque of the motor and the output current of the linearity. When the motor is with rated load and the motor current is larger than the nameplate rated standard deviation, if it is larger then reduce the value, and it is too small then increase the value

F06.18	position compensation control	Setting range: 0~1	Factory default: 0
F06.19	Compensation gain	Setting range: 0.0~250.0%	Factory default: 10.0%

F06.20	Compensation limit	Setting range:0.0~100.0%	Factory default: 0.1%
F06.21	Compensation effective range	Setting range:0.0~100.0%	Factory default: 10.0%

Position compensation on can accurately obtain the position of motor start

F06.22	Over excitation braking gain	Setting range: 0.0-500.0%	Factory default: 100.0%
F06.23	Over excitation braking amplitude limit	Setting range: 0.0~250.0%	Factory default: 100.0%

AM VC control is valid.,The over excitation function can realize much more quickly DEC control and no over-voltage. The higher over excitation is, the faster response is. Braking limit corresponds to motor rated excitation,the greater limit is, the better braking effect is. However, the excessive limit will make the motor temperature rise when DEC.Only in good heat radiation condition ,this value can be properly increased .

F06.24	Vector control energy saving function	Setting range: 0~1	Factory default: 0
F06.25	Energy saving control gain	Setting range: 0.0~80.0%	Factory default: 50.0%
F06.26	Energy saving control low-pass filter	Setting range: 0.000~6.000s	Factory default: 0.010s

Vector control energy saving function:

0: off

1: On, only valid at constant speed

2: On, valid at constant speed, acceleration and deceleration

The asynchronous machine vector control is effective. When the energy-saving operation is performed, the output current is automatically reduced by analyzing the torque output, so that the heating loss of the motor is reduced to achieve the energy-saving effect.

F06.27	Motor constant power area power limit	Setting range: 0.0-250%	Factory set: 150.0%
--------	---------------------------------------	-------------------------	---------------------

While under VC control,it can control the output power of motor shaft.If the motor runs at low/middle speed, the motor output power is lower.At this time,the motor torque is limited by the motor/generator torque[F06.08~F06.09].If the motor runs at high speed or above the rated speed,the output power is limited by [F06.27],and the output torque decrease inversely with the speed.

F06.28	Motor weak magnetic current upper limit	Setting range: 0.0-250.0%	Factory set: 60.0%
F06.29	Motor weak magnetic feed forward gain	Setting range: 0.0-200.0%	Factory set: 0.0%
F06.30	Motor weak magnetic gain	Setting range: 0.0-500.0%	Factory set: 100.0%

While under AM/PM VC control, if the motor speed is above the rated speed, or the bus voltage is lower and the running speed is near the rated speed ,the inverter need to control the motor under the weak magnetic control, so that the motor can track speed setting.

[F06.28] is set to the upper limit of demagnetizing current,and be valid to PM motor.Compared to the motor rated current, too big weak magnetic current will make the motor demagnetize irreversibly. Mostly weak magnetic current can guarantee that the motor does not demagnetize irreversibly within motor rated current ; [F06.29 ~ F06.30] set the weak magnetic control parameters. When there is instability phenomenon in the weak magnetic process, adjust this parameters group for debugging.

F06.31	Reserved
--------	----------

F06.32	MTPA gain	Setting range: 0.0-400.0%	Factory default: 100.0%
F06.33	MTPA filter time	Setting range: 0.0-100.0ms	Factory default: 1.0ms

MTPA function is optimizing the PMSM excitation strategies to achieve Max motor output / motor current; when the permanent magnet motor D, Q-axis inductance difference is large, adjust [F06.32] can significantly change the motor current under same load; adjust [F06.33] can improve the stability of the motor running.

F06.34	Reserved
--------	----------

F06.35	Low frequency pull in current	Setting range: 0.0~100.0%	Factory default: 10.0%
F06.36	High frequency pull in current	Setting range: 0.0~100.0%	Factory default: 10.0%
F06.37	Frequency of current pulled in	Setting range: 0.0~100.0%	Factory default: 10.0%

PM open-loop VC control is valid. The current is relative to motor rated current and frequency is relative to the max output frequency.The pulled in current is mainly used to promote the load ability in low frequency.The pull- in current frequency [F06.37] as high frequency distinguish threshold, if low frequency load is larger,the pull-in the current should be promote properly , but too large current will affect the efficiency of the motor.The actual use should be set up according to the load situation.

8.8 Torque Control Parameters

F07.00	Torque/Speed control	Setting range: 0-1	Factory default: 0
--------	----------------------	--------------------	--------------------

0: Speed control. With speed as the control quantity, the inverter meets the system usage requirements with speed output control to meet the speed requirements of the system.

1: Torque control. This option is valid under vector control. Torque output control, with the motor torque output as the main control target, adjust the output torque to achieve control, mainly used in tension equipment and torque requirements equipment.

Note:

- The basic parameter group F00.03-F00.07, F00.10-F00.16 is only valid in speed mode.
- In torque mode, the frequency control is detailed in F07.10-F07.13

F07.01	Torque given channel selection	Setting range: 0-7	Factory default: 0
--------	--------------------------------	--------------------	--------------------

Using a relative value for torque setting; 100.0% corresponds to motor rated torque; Setting range from 0% to 200.0%, indicating that the inverter torque is 2 times the maximum rated torque.

0: Keyboard digital reference When this option is selected, the torque value is given by the function code [F07.02].

1: reserved

2: AI1 is set by the AI1 terminal voltage or current analog input, and the voltage or current input can be selected by the switch on the control board.

3: AI2 is set by the AI2 terminal voltage or current analog input, and the voltage or current input can be selected by the switch on the control board.

4: Reserved

5: PUL is set by the high-speed pulse input from the PUL terminal. The torque setting correspondence needs to adjust the PUL related parameters.

6: RS485 communication setting Set by RS485 serial communication, communication address 0x3005/0x2005.

7: Option card

F07.02	Torque keyboard number setting	Setting range: 0-100.0%	Factory default: 0.0%
--------	--------------------------------	-------------------------	-----------------------

When the function code [F07.01] = 0, the torque setting point is given by the function code [F07.02].

F07.03	Torque input lower limit	Setting range: 0.00-100.00%	Factory default: 0.00%
F07.04	Lower limit corresponding setting	Setting range: -200.00-200.00%	Factory default: 0.00%
F07.05	Torque input upper limit	Setting range: 0.00-100.00%	Factory default: 100.00%
F07.06	Upper limit corresponding setting	Setting range: -200.00-200.00%	Factory default: 100.00%
F07.07	Given first-order filter time	Setting range: 0.000-6.000s	Factory default: 0.100s

The value of torque given channel is linearized by [F07.03-F07.06] to get the torque given value.

Given first-order filter time: Filter the torque given value to make the given torque change smoothly.

F07.08	Output torque upper limit	Setting range: 0-200.0%	Factory default: 150.0%
F07.09	Output torque lower limit	Setting range: 0-200.0%	Factory default: 0%

Output torque upper limit: Used to set the upper limit of output torque during torque control; upper limit actual output torque = rated torque * F07.08

Output torque lower limit: Used to set the output torque lower limit when torque control; lower limit actual output torque = rated torque * F07.09

F07.10	Torque control FWD speed limit selecting	Setting range: 0-7	Factory default: 0
--------	--	--------------------	--------------------

This parameter is the frequency control channel in torque mode and is used for the forward maximum operating frequency limit of the inverter.

When the inverter torque is controlled, if the load torque is less than the motor output torque, the motor speed will continue to rise. To prevent accidents such as flying in the mechanical system, the maximum motor speed during torque control must be limited.

0: Keyboard digital reference Is given by function code [F07.12].

1: reserved

2: AI1 × F07.12 is set by AI1 terminal voltage or current analog input, voltage or current input can be selected by switch on the control board

3: AI2 × F07.12 is set by AI2 terminal voltage or current analog input, voltage or current input can be selected by switch on the control board

4: Reserved

5: PUL × F07.12 High-speed pulse input from the PUL terminal.

6: RS485 communication reference × F07.12 is set by RS485 serial communication, communication address 0x3006/0x2006.

7: Optional card × F07.12

Note:

- 100.0% for each channel corresponds to the maximum frequency F00.09.
- The forward direction is the direction in which the inverter runs when the given torque of the inverter is 0% to 200% (regardless of F00.16).
- The reverse direction is the direction in which the inverter runs when the given torque of the inverter is 0% to -200% (regardless of F00.16).

F07.11	Torque control REV speed limit selecting	Setting range: 0-7	Factory default: 0
--------	--	--------------------	--------------------

0: Keyboard number given: by the function code [F07.13] given.

1: Reserved

2: AI1 × F07.13: set by the AI1 terminal analog voltage input.

3: AI2 × F07.13: set by the AI terminal analog voltage or current input, voltage or current input can be selected via the control panel switch.

4: Reserved

5: PUL × F07.13: set by PUL terminal high-speed pulse.

6: RS485 communication given × F07.13: set by the RS485 serial communication; communication address 0x3007 / 0x2007.

7: Option card × F07.13

Note: 100% corresponds to the max output frequency.

F07.12	Torque control FWD Max speed limit selecting	Set range: 0.0-100.0%	Factory default: 100.0%
F07.13	Torque control REV Max speed limit selecting	Set range: 0.0-100.0%	Factory default: 100.0%

When the function code [F07.10], [F07.11] is set to 0, the Max speed limit would be set by [F07.12], [F07.13]. And protect in case of initial debugging torque function default 100.0% as the seldom speed setting.

8.9 V/F Control Parameters

F08.00	V/F curve selection	Setting range:0-11	Factory set: 0
--------	---------------------	--------------------	----------------

V/F curve selection: used to select the V/F curve types to meet different load requirements.

- 0: Beeline
 - 1-9: 1,1-1.9 respectively VF power curve, as shown below;
 - 10: VF square curve;
 - 11: custom VF curve; see [F08.01-F08.10];
- VF default linear curve for most common situations; multi-idempotent curve and square VF curve are generally used for VF fans or pumps to reduce the high-frequency current to achieve energy savings.

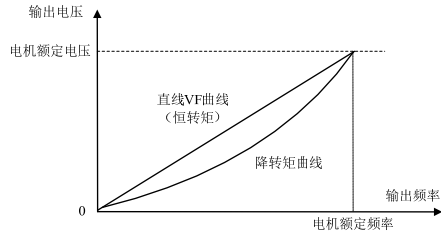

F08.01	Self-setting voltage V1	Setting range: 0.0-100.0%	Factory set: 3.0%
F08.02	Self-setting frequency F1	Setting range: 0.00-max frequency	Factory set: 1.00Hz
F08.03	Self-setting voltage V2	Setting range: 0.0-100.0%	Factory set: 208.0%
F08.04	Self-setting frequency F2	Setting range: 0.00-max frequency	Factory set: 10.00Hz
F08.05	Self-setting voltage V3	Setting range: 0.0-100.0%	Factory set: 55.0%
F08.06	Self-setting frequency F3	Setting range: 0.00-max frequency	Factory set: 25.00Hz
F08.07	Self-setting voltage V4	Setting range: 0.0-100.0%	Factory set: 708.0%
F08.08	Self-setting frequency F4	Setting range: 0.00-max frequency	Factory set: 37.50Hz
F08.09	Self-setting voltage V5	Setting range: 0.0-100.0%	Factory set: 100.0%
F08.10	Self-setting frequency F5	Setting range: 0.00-max frequency	Factory set: 50.00Hz

Self-setting V/F curve:

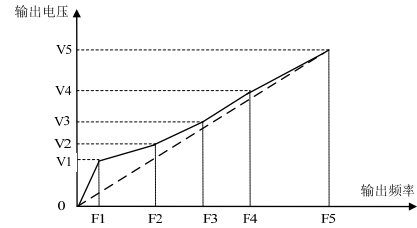

User sets the 1st/2nd/3rd/4th/5th voltage ratio of V/F curve corresponding to F1/F2/F3/F4/F5 frequency based on rated output voltage 100%. User sets the 1st/2nd/3rd/4th/5th frequency of V/F curve corresponding to V1/V2/V3/V4/V5. Must meet: 0≤F1≤F2≤F3≤F4≤F5≤max frequency, 0≤V1≤V2≤V3≤V4≤V5≤100.0%. V1, V2, V3, V4, V5 is based on motor rated voltage.

F08.11	Output voltage percentage	Setting range: 25.0-120.0%	Factory set: 100.0%
--------	---------------------------	----------------------------	---------------------

Output voltage adjustment coefficient adjusts output voltage of inverter to meet different V/F requirement.

F08.12	Torque boost	Setting range: 0.0-30.0%	Factory set: 0.0%
F08.13	Torque boost cut-off frequency	Setting range: 0.0-100.0%	Factory set: 100.0%

Torque boost:

Automatically torque boost while [F08.12] is set 0, and compensate the output voltage automatically according to the load. Fixed torque boost while [F08.12] is set other values. Improve low frequency torque trait by voltage compensation. Please set it rightly. If too high, motor maybe happens over excitation at low frequency running, over heat while long time, even over current protection or can not start normally.

Note:

- while [F08.00] is "1 custom v/f curve", [F08.12] is invalid, and inverter will running with the custom V/F curve.
- The drive only runs on a custom V/F curve.

Torque boost cut-off frequency:

Set torque improve valid range. While output frequency is over this value, torque improving function stops. 100% is corresponding to motor rated frequency.

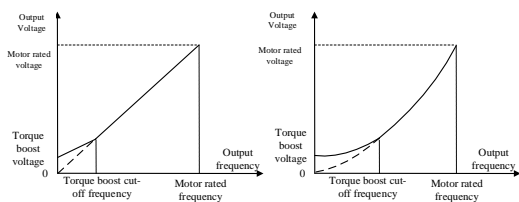

Torque lifting diagram

F08.14	slip compensation gain	Setting range:0.0-200.0%	Factory set:100.0%
F08.15	Slip compensation limit	Setting range:0.0-300.0%	Factory set:100.0%
F08.16	Slip compensation filter time	Setting range:0.000-6.000s	Factory set:0.200s

It makes inverter output frequency self adjust within a setting range according motor load change to compensate slip frequency to make motor keep constant speed. It effectively relieves the impact of load change to motor speed.

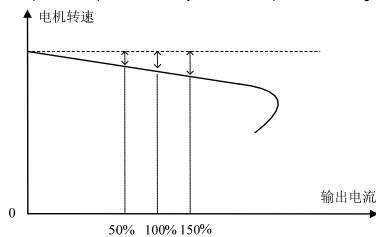

Slip compensation diagram

If it is used with the automatic torque boost function, the low frequency trait can be promoted obviously. 100.0% slip frequency compensation corresponds to the motor rated slip; it may cause the motor speed exceeds setting value when the compensation value is set too large. Hence, [F08.15] setting need to be limited. Slip compensation filter time is to filter the slip compensation to eliminate disturb signal. The longer filter time is, the stronger anti-disturb force is. The shorter filter time is, the weaker anti-disturb force is. But respond speed will be quicker.

The slip compensation function needs to correctly input the motor nameplate parameters and learn the parameters to achieve the best results.

F08.17	Surge suppression gain	Setting range: 0.0-900.0%	Factory set: 100.0%
--------	------------------------	---------------------------	---------------------

While the motor control mode F0.00=0 or 1, it is easily to appear motor current instability and motor speed oscillation

phenomenon in medium and high power occasions, which is a combination of electrical and mechanical effects of low-frequency resonance. It is possible to suppress the low frequency resonance by adjusting the [F08.17], but excessive suppression gain may lead to additional stability problems.

F08.18	Reserved		
F08.19	Auto energy saving control	Setting range: 0-1	Factory set: 0
F08.20	Energy saving frequency lower limit	Setting range: 0.0-50.0Hz	Factory set: 15.00Hz
F08.21	Energy saving voltage lower limit	Setting range: 0.0-100.0%	Factory set: 50.0%
F08.22	Energy saving voltage regulation rate	Setting range: 0~0.200V/MS	Factory set:0.010V/MS
F08.23	Energy saving voltage recovery rate	Setting range: 0~0.200V/MS	Factory set:0.200V/MS

Auto energy save selection:

Under the condition of light load, the motor can adjust the output voltage automatically after entering the constant speed to promote the efficiency to save energy.

0: OFF

1: ON

Energy saving frequency lower limit:

When output frequency is lower than this value, auto energy save function will exit.

Energy saving voltage lower limit: While automatically saving energy running, the lower limit of the voltage can reduce. 100.0% is corresponding to the current output voltage corresponding to the output frequency without saving energy.

Energy saving voltage regulation rate:

The rate of voltage regulation during the process of energy saving.

Energy saving voltage recovery rate:

The rate of voltage recovery to the normal voltage while exit the energy saving process.

Note: Enter energy saving only at constant speed running, hence this function is not suitable to be used in occasions where the given frequency changes frequently.

F08.24~F08.34	Reserved
---------------	----------

8.10 Malfunction and Protection Parameters

F10.00	OC suppression function	Setting range: 0-1	Factory default: 0
F10.01	OC suppression point	Setting range: 0.0-300.0%	Factory default: 160.0%
F10.02	OC suppression gain	Setting range: 0.0-500.0%	Factory default: 100.0%

OC suppression function:

The OC suppression function can monitor the real-time load current, and automatically limit it below the set of OC suppression point, to prevent the fault trip caused by excessive current. To some large inertia or sharp changing load, the function is especially valid..

0: Suppression valid**1: ACC/DEC valid, constant speed invalid****OC suppression point:**

Set current limit level (By stopping ACC/DEC or decreasing/ increasing output frequency to control the output current).

OC suppression gain:

Adjust the response speed of OC suppression.

Note: Using this function might prolong ACC/DEC time. During the process of inverter start/ stop, if in the case of high current, the output frequency will not ACC/DEC to the given frequency as expected, which shows that the limiting function. At that time, please reduce the load or adjust relevant parameters.

F10.03	Current hardware protection settings	Setting range: 0000-0221	Factory set: 0001
--------	--------------------------------------	--------------------------	-------------------

LED "0" digit: cycle-by-cycle current limit:

cycle-by-cycle current limit can limit current rise to a certain extent by hardware protection so that the current does not exceed the protection value of the inverter and avoid skipping flow fault shutdown.

0: Close

1: Open

LED "00" digit: OC protection disturbing suppression

While this function is valid, inverter will judge the E. OC alarm intelligently to eliminate the disturbance, and only make the alarm to the real fault signal. This function may delay the alarm time, and please use it cautiously.

0: Off

1: First grade disturbing suppression

2: Second grade disturbing suppression

LED "000" digit: SC protection First grade disturbing suppression

While this function is valid, inverter will judge the E. SC alarm intelligently to eliminate the disturbance, and only make the alarm to the real fault signal. This function may delay the alarm time, and please use it cautiously.

0: Off

1: First grade disturbing suppression

2: Second grade disturbing suppression

LED "0000" digit: Reserved

F10.04-F10.05	Reserved
---------------	----------

F10.06	Bus over voltage suppression protection	Setting range: 0000-0012	Factory set: 0012
--------	---	--------------------------	-------------------

LED "0" digit: Over voltage suppression control

0: Prohibited

1: Valid in DEC

2: Valid both in ACC/DEC

Select whether DEC OV suppression is valid :if this function is valid, when bus voltage reaches or exceeds [F10.07] when inverter DEC running, the inverter will slow down or stop DEC, thus ensuring there's no OV protection due to high bus voltage.

Select whether ACC OV suppression is valid :if this function is valid, when bus voltage reaches or exceeds [F10.07] when inverter ACC running, the inverter will automatically adjust the operating frequency and suppress the bus voltage from increasing, thus ensuring there's no OV protection due to high bus voltage. This function is special valid to eccentric load.

LED "00" digit: Overexcitation control

0: Off

1: On

LED "000" digit: Reserved**LED "0000" digit: Reserved**

Note: When using the energy consumption setting functions, please turn off or turn on the overvoltage suppression control according to the site conditions.

F10.07	Bus over voltage suppression point	T3: 650-780 (default 750) T2/S2: 340-380 (default 365)	Factory default: 128.0%
F10.08	Bus over voltage suppression gain	Setting range: 0.0-500.0%	Factory default: 100.0%

When bus voltage reaches or exceeds [F10.07] when inverter running, the inverter will automatically adjust the operating frequency and suppress the bus voltage from increasing, thus ensuring there's no OV protection due to high bus voltage. Adjusting [F10.08] can promote OV suppression effect; set [F10.08] = 0: cut-off OV suppression function and OV suppression is valid for any motor control mode.

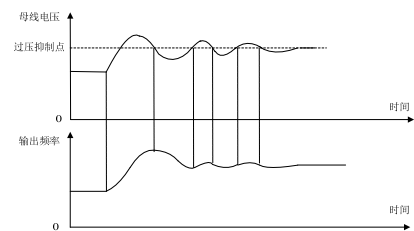

Overvoltage suppression diagram

F10.09	Bus under-voltage suppression function	Setting range: 0~1	Factory default: 0
F10.10	Bus under voltage suppression point	T3: 350-450 (default 430) T2/S2: 180-260 (default 240)	Factory default: 80.0%
F10.11	Bus under voltage suppression gain	Setting range: 0.0-500.0%	Factory default: 100.0%

When bus voltage reaches or lower than [F10.10] when inverter running, the inverter will automatically adjust the operating frequency and suppress the bus voltage from decreasing, thus ensuring there's no LV protection due to low bus voltage. Adjusting [F10.11] can promote LV suppression effect; set [F10.09] = 0: cut-off LV suppression function and LV suppression is valid for any motor control mode.

F10.12	Bus under-voltage protection point	Setting range: 60.0-90.0%	Factory default: 60.0%
--------	------------------------------------	---------------------------	------------------------

Bus under-voltage protection point: This parameter specifies the lower voltage allowed by bus voltage during operation, for some low power occasions, appropriate under-voltage protection level can be reduced to ensure the normal working of the inverter.

Note: When the grid voltage is too low, the motor output torque will decrease. For constant power load and constant torque load, low grid voltage will increase the frequency converter input and output current, thereby reducing the reliability of the inverter operation.

F10.13	Input phase loss threshold	Setting range: 0.0% to 30.0%	Factory default: 10.0%
--------	----------------------------	------------------------------	------------------------

Input phase loss threshold: When the input phase loss detection function is turned on, when the field voltage fluctuation is large, the threshold value can be appropriately increased without affecting the normal operation of the machine.

F10.14	Power-to-ground short-circuit detection	Setting range: 0000-0012	Factory default: 0011
--------	---	--------------------------	-----------------------

LED "0" digit: short circuit to ground When the motor connected to the inverter is short-circuited to ground, it will report the output phase loss fault E.SG.

- 0: off
- 1: Power-on detection
- 2: Test every run

LED "00" digit: fan short circuit When the inverter fan short circuit occurs when the fan is short-circuited (or 24V short circuit), the inverter will restart 2 times. Will report the output phase loss fault E.FSG.

- 0: off
- 1: open

LED "000" digit: Reserved

LED "0000" digit: Reserved

F10.15	Phase loss protection	Setting range: 0000-0021	Factory default: 0011
--------	-----------------------	--------------------------	-----------------------

LED "0" digit: output phase protection:

- 0: Close
- 1: Open

LED "00" digit: input phase protection:

- 0: Off
- 1: Open the alarm
- 2: Open the fault

LED "000" digit: Reserved

LED "0000" digit: Reserved

F10.16	Motor overload protection curve coefficient	Set range: 0.0-250.0%	Factory default: 100.0%
--------	---	-----------------------	-------------------------

Long term motor overload would produce serious heat, [F10.16] sets the coefficient of load motor overload protection or thermal protection; the motor overload protection and motor current curve was inverse, protection curve when F10.16 = 100.0% is shown as follows:

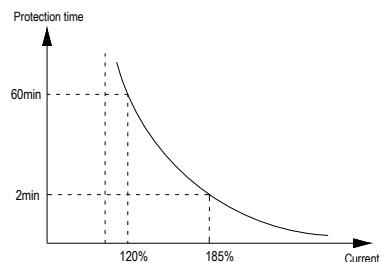

The current entering protection curve= (the real motor current / oL protection coefficient)x110%

So increasing [F10.16] can improve motor overload; overload pre alarm coefficient can be set by [F10.16], when the motor had reached the degree of overload factor [F10.16] setting, the inverter outputs alarm by terminal, for details please see Y terminal function.

Note: When a inverter parallel with several motors in operation, th the thermal relay protection function will have no use, in order to effectively protect the motor, please install the thermal protection relay at the end of each motor.

F10.17	Load pre alarm detection setting	Setting range: 0000~1414	Factory default: 0000
--------	----------------------------------	--------------------------	-----------------------

LED "0" digit: Detection selection (protection 1)

- 0: Not detected
- 1: Detected load is too large
- 2: Detected load is too large only at constant speed
- 3: Insufficient load detected
- 4: Insufficient load only at constant speed

LED "00" digit: Alarm selection

- 0: Alarm and continue operation
- 1: Fault protection and free stop

LED "000" digit: Detection selection (protection 2)

- 0: Not detected
- 1: Detected load is too large
- 2: Detected load is too large only at constant speed
- 3: Insufficient load detected
- 4: Insufficient load only at constant speed

LED "0000" digit: Alarm selection

- 0: Alarm and continue operation
- 1: Fault protection and free stop

F10.18	Load pre alarm detection level 1	Setting range: 0.0~200.0%	Factory default: 130.0%
F10.19	Load pre alarm detection time 1	Setting range: 0.0~60.0s	Factory default: 5.0s
F10.20	Load pre alarm detection level 2	Setting range: 0.0~200.0%	Factory default: 30.0%
F10.21	Load pre alarm detection time 2	Setting range: 0.0~60.0s	Factory default: 5.0s

In the VF control mode, the motor output current is used as the load warning judgment value, 100.0% corresponds to the rated motor current; in the vector control mode, the motor output torque is used as the load warning judgment value, 100.0% corresponds to the rated output torque of the motor, and the load warning judgment value is The detection time [F10.19/F10.21] is compared with the detection threshold [F10.18/F10.20], and the corresponding action is performed according to [F10.17]. The alarm can be output through the terminal output. See Y Terminal function for details.

Check out the selection (Protection 1):**1: Detection load is too large**

The running detection value is greater than [F10.18] load warning detection level 1 and the valid signal is output after [F10.19] load warning detection time 1;

2: Excessive load detection only at constant speed

In the constant speed state, the detected value is greater than [F10.18] load warning detection level 1 and the valid signal is output after [F10.19] load warning detection time 1;

3: Insufficient detection load

The running detection value is less than [F10.20] load warning detection level 2 and the valid signal is output after [F10.21] load warning detection time 2;

4: Insufficient load detection only at constant speed

128

In the constant speed state, the detected value is less than [F10.20] load warning detection level 2 and the effective signal is output after [F10.21] load warning detection time 2;

Checkout selection (Protection 2): Same checkout selection (Protection 1)

F10.22	Reserved
--------	----------

F10.23	Protection action when speed slip is too large	Setting range: 0000-0012	Factory default: 0000
--------	--	--------------------------	-----------------------

LED "0" digit: Detection selection

- 0: Not detected
- 1: Detected at constant speed
- 2: Detecting

LED "00" digit: Alarm selection

- 0: Free stop and report fault
- 1: Alarm and continue operation

LED "000" digit: Reserved**LED "0000" digit: Reserved**

F10.24	detection threshold when speed slip is too large	Set range: 0.0-60.0%	Factory default: 10.0%
F10.25	detection time when speed slip is too large	Set range:0.0-60.0s	Factory default: 2.0s

Under VC control,if the speed feedback value and speed setting bias are more than detection threshold [F10.24] during the detection time [F10.25], inverter judges that the detection bias is too large and operate according to [F10.23].Speed bias detection threshold 100% corresponds to max frequency..

F10.26	Rapid protection action	Setting range: 0000-0012	Factory default: 0000
--------	-------------------------	--------------------------	-----------------------

LED "0" digit: Detection selection

- 0: Not detected
- 1: Detected at constant speed
- 2: Detecting

LED "00" digit: Alarm selection

- 0: Free stop and report fault
- 1: Alarm and continue operation

LED "000" digit: Reserved**LED "0000" digit: Reserved**

F10.27	Rapid detection threshold	Setting range: 0.0~150.0%	Factory default: 110.0%
F10.28	Rapid detection time	Setting range:0.000~2.000s	Factory default: 0.010s

129

Under VC control, if the speed feedback value is more than detection threshold [F10.27] during the detection time [F10.28], inverter judges that the speed abnormal and operate according to [F10.26]. Speed bias detection threshold 100% corresponds to max frequency..

F10.29	Motor overheat protection selection (extended)	Setting range: 0000-0021	Factory default: 0000
--------	--	--------------------------	-----------------------

LED "0" digit: temperature detection type selection

- 0: PT100,
- 1: KTY

LED "00" digit: temperature detection action

- 0: no detection
- 1: alarm and free parking
- 2: Warning and continue to run

LED "000" digit: Reserved

Note: PT100 is preferentially selected by the DIP switch. When the DIP switch is dialed to KTY/PT100, the temperature detection type is set by F10.29.

F10.30	Motor overheat protection threshold (extended)	Setting range: 0.0~200.0°C	Factory default: 100.0 °C
F10.31	Motor overheat warning threshold (extended)	0.0~200.0 °C (A.oH3 exceeded the threshold warning)	Factory default:90.0

When the motor temperature is greater than the overheat protection threshold, report the fault or warning according to F10.29 E.OH3, A.oH3

F10.38	Malfunction auto-reset times	Setting range: 0-5	Factory default: 0
F10.39	Malfunction auto-reset interval	Setting range: 0.1-100.0s	Factory default:1.0s

Malfunction auto-reset times:

- 0: Off** No automatic reset function; manual reset.
- 1-5: On** 1-5 is the automatic reset times;

The inverter would fail or stop during operation due to load fluctuations, voltage fluctuations and other factors. At this time in order to ensure continuity of system operation, automatic resets of inverter for overload, over current, system abnormalities, over voltage, under voltage faults are allowed. The inverter would restart by speed tracking in the process of self recovery. If the inverter can't restart within the set times, stop output for fault protection; Fault recovery times can be set up to five times, after 10 minutes running the fault recovery times would be re-recorded and the times before is automatically cleared. Consecutive failures of restarting might cause harm, so the proposed fault recovery time is 1;

Output terminal can be selected to act or not act in automatic reset process. Details refer to [F02.45-F02.47].

Malfunction auto-reset interval: It defines waiting time before resetting after fault.

Note:

- Only valid for fault of OL, OC, system abnormal, under voltage. Not valid for other faults.
- Can't reset before dealing with malfunction.

Attention: Please use this function carefully in occasions that can't start with load, or that needs alarm immediately when there's no output.

8.11 PID Parameters

PID control is used for process control mode normal. For the aim of that the object which be controlled is stabilized as the PID given, it adjusts inverter output frequency to form passive feedback PID adjustment by series of proportional, integral, differential calculation by difference between the feedback of that be controlled and the inverter PID given.

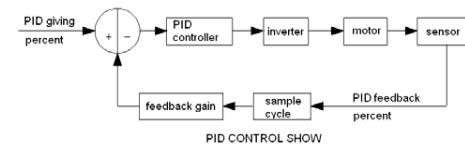

F11.00	PID give signal source	Setting range: 0-8	Factory set: 0
--------	------------------------	--------------------	----------------

Use to set the input channel of PID controller given signal.

0: Keyboard number given PID Decided by [F11.01] setting.

1: Reversed

2: AI1: set by the AI1 terminal analog voltage input.

3: AI2: set by the AI terminal analog voltage or current input.

4: Reversed

5: PUL set by PUL terminal high-speed pulse.

6: RS485 communication given: set by the RS485 serial communication; communication address 0x3008 / 0x2008.

7: Option card: set by option card. Details refer to option card specification.

8: Terminal selection PID giving is selected by multifunction input terminal combine which is set by [F02.00-F02.06].

9: Communication given active current

Terminal switch table:

Terminal 3	Terminal 2	Terminal 1	PID giving terminal switch selection
OFF	OFF	OFF	Keyboard number give PID
OFF	OFF	ON	Keyboard potentiometer
OFF	ON	OFF	Terminal AI1 voltage analog

OFF	ON	ON	Terminal AI analog
ON	OFF	OFF	Terminal AS current analog
ON	OFF	ON	Terminal PUL pulse signal
ON	ON	OFF	RS485 communication
ON	ON	ON	Optional card

Any doubt please see "FC" parameter group which is about multispeed time sequence.

F11.01	Keyboard number PID given/feedback	Setting range: 0.00-100.0%	Factory set: 50.0%
--------	------------------------------------	----------------------------	--------------------

This function is valid only when [F11.00]/[F11.03] is set as keyboard number given/feedback. After this parameter is changed, PID given in monitor object is modified automatically at the same time.

If [F11.09] LED "0" is set as 2, this value can be modified by UP/DW key. Whether save the modification is decided by [F04.09] LED "00" digit.

F11.02	PID given changing time	Setting range:0.00-60.00	Factory set:1.00s
--------	-------------------------	--------------------------	-------------------

PID given changing time:

the ratio of PID given changing time from 0.0% to 100.0%. While PID given changes,PID given changes in linear line by the given time to reduce the bad influence of given surge.

F11.03	PID feedback signal source	Setting range:0-9	Factory set:2
--------	----------------------------	-------------------	---------------

Set the input channel of the PID controller feedback signal.

0: Keyboard digital PID feedback The PID feedback channel is determined by the setting value of [F11.01].

1: reserved

2: Voltage/current analog AI1 feedback The PID feedback channel is the voltage/current analog AI1.

3: Voltage/current analog AI2 feedback The PID feedback channel is the voltage/current analog AI2.

4: Reserved.

5: Terminal pulse PUL feedback The PID feedback channel is the terminal pulse PUL.

6: RS485 communication feedback The PID feedback channel is RS485 communication, and the communication address is 0x3009/0x2009.

7: Optional card The PID feedback channel is an optional card. For details, refer to the optional card manual.

8: Terminal selection The PID feedback channel is selected by the combination of multi-function input terminals. The multi-function input terminal is set by [F02.00~F02.09].

9: Communication given active current

Terminal switch table:

Terminal 3	Terminal 2	Terminal 1	PID giving terminal switch selection
------------	------------	------------	--------------------------------------

OFF	OFF	OFF	Keyboard number give PID
OFF	OFF	ON	Keyboard potentiometer
OFF	ON	OFF	Terminal AI1 voltage analog
OFF	ON	ON	Terminal AI analog
ON	OFF	OFF	Terminal AS current analog
ON	OFF	ON	Terminal PUL pulse signal
ON	ON	OFF	RS485 communication
ON	ON	ON	Optional card

Any doubt please see "FC" parameter group which is about multispeed time sequence.

Note: The PID signal source and PID controller feedback signal source cannot be set to the same channel, otherwise the PID will not work normally.

F11.04	Feedback signal filter time	Setting range: 0.000-6.000s	Factory set: 0.010s
F11.05	Feedback signal gain	Setting range: 0.00-10.00	Factory set: 1.00
F11.06	Given and feedback range	Setting range: 0-100.0	Factory set: 100.0

Feedback signal filter time:

Filter the feedback signal to eliminate to the disturb. The longer filter time is, the stronger anti-disturb force is, but the slower feedback response is.

Feedback signal gain:

It is used to linearize the feedback input signal.

Given and feedback range:

PID given and feedback don't have the unit to adjust the PID given (C-08) and PID feedback display(C-09).PID given and feedback 100.0% corresponds with the given and feedback range[F11.06].For example,[F11.06]is set 80.0,if the PID given 50.0%, and then PID given display C-08 is 40.0.

F11.07	PID control selection	Setting range: 0000-1111	Factory set: 0000
--------	-----------------------	--------------------------	-------------------

LED "0" digit: feedback trait selection

0: Positive trait. It is suitable for occasions where PID feedback is bigger than PID given and requires reduce output frequency PID to balance PID. Such as constant pressure water supply, gas supply, take-up tension control.

1: Negative trait. It is suitable for occasions where PID feedback is bigger than PID given and requires raise output frequency PID to balance PID. Such as constant temperature control, pay-off tension control.

LED "00" digit: Reserved

LED "000" digit: Reserved

LED "0000" digit: Differential adjustment properties

0: Differential of deviation

1: Differential of feedback

F11.08	PID preset output	Setting range: 0.00-100.0%	Factory set: 100.0%
F11.09	PID preset output running time	Setting range: 0.0-6500.0s	Factory set: 0.0s

While it defines as PID start running, frequency ACC to PID pre-set output [F11.08] according to ACC time 1. After setting [F11.09] time, it runs as PID closed loop trait.

Note: When PID is used for frequency source given, [F0.03 = 8] preset outputs 100.0% corresponding maximum output frequency.

F11.10	PID control deviation limit	Setting range: 0.00-100.0%	Factory default: 0.0%
--------	-----------------------------	----------------------------	-----------------------

The max deviation allowed by PID feedback to PID given. When feedback is in this range, PID adjustment stops. Output does not change; the reasonable use of the feature helps coordinate the contradiction between system output accuracy and stability.

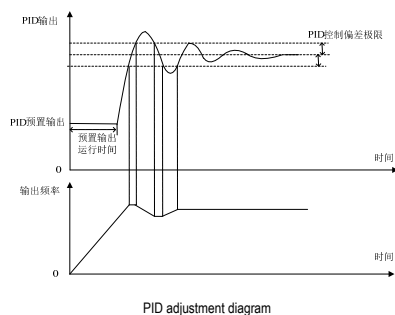

F11.11	Proportion gain: P1	Setting range: 0.000-9.999	Factory set: 0.100
F11.12	Integral time: I1	Setting range: 0.0-600.0s	Factory set: 1.0s
F11.13	Differential coefficient : D1	Setting range: 0.000-6.000s	Factory set: 0.000s
F11.14	Proportion gain: P2	Setting range: 0.000-9.999	Factory set: 0.100
F11.15	Integral time: I2	Setting range: 0.0-600.0s	Factory set: 1.0s
F11.16	Differential coefficient : D2	Setting range: 0.000-6.000s	Factory set: 0.000s

The parameter value controlled by PID should be set according to the actual characteristics of the system. PID parameters group 1 (F11.11~F11.13) and PID parameters group 2(F11.14~F11.16) ,are selected by the switch conditions [F11.17] set.

Proportion gain P:

It decides impact of P act to bias. Response is quicker while gain is bigger. But there will be surge while it is too big.

Integral time I:

It decides the size of effect of I act. The impact is stronger while the I is bigger.

Differential coefficient D:

Decide the impact of change rate of PIN controller to bias or feedback signal. According to the change trend, to adjust to suppression the change of feedback signal.

F11.17	PID parameter switching condition	Setting range: 0-2	Factory set:0
F11.18	Low value of switching deviation	Setting range: 0.0-100.0%	Factory set: 20.0%
F11.19	High value of switching deviation	Setting range: 0.0-100.0%	Factory set: 80.0%

In some occasions, just one group of PID adjusting parameters can ont meet the requirement of the process ,hence different PID parameters group need to be adopted in different occasions.

PID parameter switching condition:

0: Not switch PID parameters select the group 1 (F11.11~F11.13)

1: Use DI terminal to switch Multi function terminal selection is set 23 (PID parameters switch).While this terminal is invalid, select PID group 1 (F11.11~F11.13); while this terminal is valid,select group 2(F11.14~F11.16).

2: Switch according to deviation While the deviation absolute value of PID given and feedback is less than [F11.18], select group 1;while the deviation absolute value of PID given and feedback is more than [F11.19], select group 2;while the deviation absolute value of PID given and feedback is between [F11.18] and [F11.19], select the linear interpolation value of the 2 groups,which is as follows;

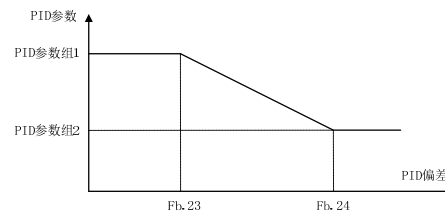

Switching the PID parameters according to the deviation

F11.20	Reserved		
--------	----------	--	--

F11.21	Differential limit	Setting range: 0.0-100.0%	Factory set: 5.0%
--------	--------------------	---------------------------	-------------------

[F11.21] differential limit is used to set PID differential output range. In PID controller, the differential effect is sensitive, and easy to make the system oscillation. Usually, limit the PID differential range within a small scale.

F11.22	PID output upper limit	Setting range: 0.0-100.0%	Factory set: 100.0%
F11.23	PID output lower limit	Setting range: -100.0-F11.19	Factory set: 0.0%
F11.24	PID output filter time	Setting range: 0.000-6.000s	Factory set: 0.0s

[F11.22] is used to set the PID output upper limit.[F11.23] sets the PID output lower limit.

[F11.24] PID output filter time used to filter the PID output.It will weak the surge caused by PID output result, and decrease the closed-loop system response performance.

F11.25	Detection time while feedback wire break	Setting range: 0.0-120.0s	Factory set: 1.0s
F11.26	Act selections while feedback wire break	Setting range: 0-3	Factory set: 0
F11.27	Wire break alarm upper limit	Setting range: 0.0-100.0%	Factory set: 100.0%
F11.28	Wire break alarm lowest limit	Setting range: 0.0-100.0%	Factory set: 0.0%

While PID given frequency and inverter is running, if feedback signal which is bigger the [F11.27] or smaller than [F11.28] is detected out and keeps for [F11.25] delay time, it is considered as sensor wire break.

Feedback wire-break action selections

0: Go on PID operation without alarm: no wire-break detection when invalid

1: Stop and alarm malfunction: When the inverter detects a sensor break, immediately block output, motor free stop and report E.PID fault.

2: Go on PID operation and output alarm signal: When the inverter detects a sensor break, still run by the PID regulation, but the keyboard displays E.PID fault and flashes.

3: Run the current frequency and output alarm signal: When the inverter detects a sensor break, maintain constant output frequency before the fault, but the keyboard displays E.PID fault and flashes.

Wire break alarm upper limit:

Set the upper limit of PID sensor wire break detection.When feedback signal is over alarm upper limit for time [F11.25], it is considered as sensor wire break.

Wire break alarm lower limit:

Set the lower limit of PID sensor wire break detection.When feedback signal is under alarm upper limit for time [F11.25], it is considered as sensor wire break.

F11.29	Constant pressure water supply sleep selection	0: Invalid 1: Valid	Factory default: 0
F11.30	Sleep frequency	0.00Hz ~ max frequency F0.09	Default: 10.00
F11.31	Sleep delay	0.0-3600.0 s	Default: 60.0
F11.32	Wake-up deviation	0.0-50.0%	Default: 5.0
F11.33	Wake-up delay	0.0-60.0S	Default: 1.0

Constant pressure water supply sleep selection:

0: Invalid no sleep detection

1: Valid for sleep detection

Sleep into the judgment:

When the constant pressure water supply sleep function is valid, when the PID adjustment output frequency is lower than the set [F11.30] sleep frequency, it will enter the sleep state after the [F11.31] sleep delay (ie, the output will be blocked after deceleration to zero frequency).

Sleep wakeup judgment:

When the PID feedback characteristic is positive:

The PID reference (C00.08) minus the wake-up deviation (F11.32) is compared with the PID feedback (C00.09). If it continues to be greater than the wake-up delay [F11.33], it exits the sleep state and enters the normal operating status.

When the PID feedback characteristic is inverse characteristic:

The PID reference (C00.08) plus the wake-up deviation (F11.32) is compared with the PID feedback (C00.09). If it continues to be greater than the wake-up delay [F11.33, exit the sleep state and enter the normal running state.

8.12 Multistep, PLC Function and Swing Frequency Parameters

F12.00	Step 1	Setting range: 0.00-max frequency	Factory set: 10.00Hz
F12.01	Step 2	Setting range: 0.00-max frequency	Factory set: 20.00 Hz
F12.02	Step 3	Setting range: 0.00-max frequency	Factory set: 30.00 Hz
F12.03	Step 4	Setting range: 0.00-max frequency	Factory set: 40.00 Hz
F12.04	Step 5	Setting range: 0.00-max frequency	Factory set: 50.00 Hz
F12.05	Step 6	Setting range: 0.00-max frequency	Factory set: 40.00 Hz
F12.06	Step 7	Setting range: 0.00-max frequency	Factory set: 30.00 Hz
F12.07	Step 8	Setting range: 0.00-max frequency	Factory set: 20.00 Hz
F12.08	Step 9	Setting range: 0.00-max frequency	Factory set: 10.00 Hz
F12.09	Step 10	Setting range: 0.00-max frequency	Factory set: 20.00 Hz
F12.10	Step 11	Setting range: 0.00-max frequency	Factory set: 30.00 Hz
F12.11	Step 12	Setting range: 0.00-max frequency	Factory set: 40.00 Hz
F12.12	Step 13	Setting range: 0.00-max frequency	Factory set: 50.00 Hz
F12.13	Step 14	Setting range: 0.00-max frequency	Factory set: 40.00 Hz
F12.14	Step 15	Setting range: 0.00-max frequency	Factory set: 30.00 Hz

It sets run frequency of 15 steps in PLC and multistep control.

Mult steps control has priority only after JOG. While multi steps control, 4 multifunction input terminals are needed to set as control terminals. Set details refer to [F02.00-F02.06].

Inverter is running at which step is decides by the ON/OFF state of 4 control terminal and COM. Run and direction is controlled by run signal and direction given by [F0.02]. ACC/DEC time default is ACC/DEC time 1 [F0.14], [F0.15]. Or select ACC/DEC time by ACC/DEC time selection terminal set by [F02.00-F02.06].

Multi-speed terminal 4	Multi-speed terminal 3	Multi-speed terminal 2	Multi-speed terminal 1	terminal speed
OFF	OFF	OFF	ON	1X [F12.00]
OFF	OFF	ON	OFF	2X [F12.01]
OFF	OFF	ON	ON	3X [F12.02]
OFF	ON	OFF	OFF	4X [F12.03]
OFF	ON	OFF	ON	5X [F12.04]
OFF	ON	ON	OFF	6X [F12.05]
OFF	ON	ON	ON	7X [F12.06]
ON	OFF	OFF	OFF	8X [F12.07]
ON	OFF	OFF	ON	9X [F12.08]
ON	OFF	ON	OFF	10X [F12.09]
ON	OFF	ON	ON	11X [F12.10]
ON	ON	OFF	OFF	12X [F12.11]
ON	ON	OFF	ON	13X [F12.12]
ON	ON	ON	OFF	14X [F12.13]
ON	ON	ON	ON	15X [F12.14]

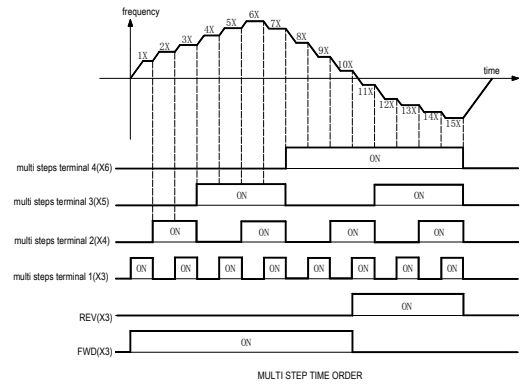
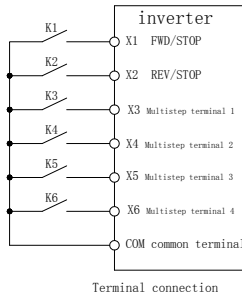

F12.15	PLC run mode selections	Setting range: 0000-2212	Factory set: 0000
--------	-------------------------	--------------------------	-------------------

Select PLC running mode while program given.

LED "0" digit: cycle mode

0: Stop after single cycle While receiving order, inverter run from the first step, time unit is set by [F12.15] LED "00" digit. Running time is set by [F12.16-F12.30]. Running direction and ACC/DEC time is selected by [F12.31-F12.45]. Turn to next step while run time is over, run time, direction, ACC/DEC time of every step can be set separately. Inverter output 0 Hz while finished 15 steps running. If one step running time is 0, it will skip this step.

1: Continuous cycles Inverter not stop and runs at the latest speed while finished 15 steps running. Time unit is set by [F12.15] LED "00" digit. Run time is set by [F12.16-F12.30]. Run direction and ACC/DEC time is selected by [F12.31-F12.45].

2: Keep final value after single cycle Inverter back to 1st step while finished 15 steps running. Time unit is set by [F12.15] LED "00" digit. Run time is set by [F12.16-F12.30]. Run direction and ACC/DEC time is selected by [F12.31-F12.45].

Note: PLC ACC/DEC time is set by [F12.31-F12.45] LED "00", and not be affected by terminal selection.

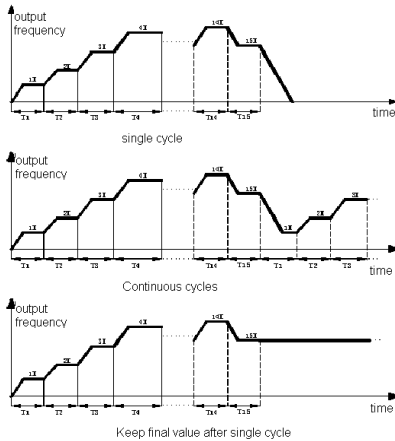

LED"00" digit: Time unit

- 0: second
- 1: minute
- 2: hour

LED"000" digit: Power down save mode

- 0: no save
- 1: save

This parameter is defined as when the selection process is running, the inverter power whether to store the current state of the running program (running stages, the remaining time of this stage, deceleration and running direction , etc.). If you choose power down storage, the "000" digit of [F12.15] defines the way power is restored of the next running. To ensure sustainable state of inverter after power recovery, the parameter should be set as "1".

LED"0000" digit: Start-up mode

- 0: Restart from the 1st step
- 1: Restart from the step where stop
- 2: Restart from the time when stop

Set restart mode while stop for some reasons (stop, fault, power off and so on).

- Choosing 0: Restart from the 1st step
- Choosing 1: Restart from the step when stop
- Choosing 2: Continue from the time when stop

Note: Output frequency is limited by upper/lowest limitation. While frequency is lower than lowest limitation, it runs as [F0.13] lowest limitation mode.

F12.16	PLC 1st step running time	Setting range: 0.0-6500.0(s/m/h)	Factory set: 10.0
F12.17	PLC 2nd step running time	Setting range: 0.0-6500.0(s/m/h)	Factory set: 10.0
F12.18	PLC 3rd step running time	Setting range: 0.0-6500.0(s/m/h)	Factory set: 10.0
F12.19	PLC 4th step running time	Setting range: 0.0-6500.0(s/m/h)	Factory set: 10.0
F12.20	PLC 5th step running time	Setting range: 0.0-6500.0(s/m/h)	Factory set: 10.0
F12.21	PLC 6th step running time	Setting range: 0.0-6500.0(s/m/h)	Factory set: 10.0
F12.22	PLC 7th step running time	Setting range: 0.0-6500.0(s/m/h)	Factory set: 10.0
F12.23	PLC 8th step running time	Setting range: 0.0-6500.0(s/m/h)	Factory set: 10.0
F12.24	PLC 9th step running time	Setting range: 0.0-6500.0(s/m/h)	Factory set: 10.0
F12.25	PLC 10th step running time	Setting range: 0.0-6500.0(s/m/h)	Factory set: 10.0
F12.26	PLC 11th step running time	Setting range: 0.0-6500.0(s/m/h)	Factory set: 10.0
F12.27	PLC 12th step running time	Setting range: 0.0-6500.0(s/m/h)	Factory set: 10.0
F12.28	PLC 13th step running time	Setting range: 0.0-6500.0(s/m/h)	Factory set: 10.0
F12.29	PLC 14th step running time	Setting range: 0.0-6500.0(s/m/h)	Factory set: 10.0
F12.30	PLC 15th step running time	Setting range: 0.0-6500.0(s/m/h)	Factory set: 10.0

Set running time of every 15 steps. Time unit is decided by [F12.15] LED "00" digit setting.

F12.31	PLC 1st step direction and ADD/DEC time	Setting range: 0000-0031	Factory set: 0000
F12.32	PLC 2nd step direction and ADD/DEC time		Factory set: 0000
F12.33	PLC 3rd step direction and ADD/DEC time		Factory set: 0000
F12.34	PLC 4th step direction and ADD/DEC time		Factory set: 0000
F12.35	PLC 5th step direction and ADD/DEC time		Factory set: 0000
F12.36	PLC 6th step direction and ADD/DEC time		Factory set: 0000
F12.37	PLC 7th step direction and ADD/DEC time		Factory set: 0000
F12.38	PLC 8th step direction and ADD/DEC time		Factory set: 0000
F12.39	PLC 9th step direction and ADD/DEC time		Factory set: 0000
F12.40	PLC 10th step direction and ADD/DEC time		Factory set: 0000
F12.41	PLC 11th step direction and ADD/DEC time		Factory set: 0000
F12.42	PLC 12th step direction and ADD/DEC time		Factory set: 0000
F12.43	PLC 13th step direction and ADD/DEC time		Factory set: 0000
F12.44	PLC 14th step direction and ADD/DEC time		Factory set: 0000
F12.45	PLC 15th step direction and ADD/DEC time		Factory set: 0000

Set running direction and ACC/DEC time of every 15 step while program running.

LED "0" digit: this step run direction

- 0: FWD

1: REV

If [F0.16] LED "00" digit is 1 only the FWD command is allowed, and if setting is REV, inverter runs as 0.00Hz.

LED "00" digit: ACC/DEC time in this step

0: ACC/DEC time 1

1: ACC/DEC time 2

2: ACC/DEC time 3

4: ACC/DEC time 4

LED "000" digit: reserved**LED "0000" digit: reserved**

F12.46-F12.48	Reserved
---------------	----------

F12.49	Swing frequency control	Setting range: 0-1	Factory default: 0
F12.50	Swing amplitude control	Setting range: 0-1	Factory default: 0
F12.51	Reserved		
F12.52	Swing frequency amplitude	Setting range: 0.0-100.0%	Factory default: 10.0%
F12.53	Jump frequency amplitude	Setting range: 0.0-50.0%	Factory default: 10.0%
F12.54	Swing frequency rising time	Setting range: 0.00-650.00s	Factory default: 5.00s
F12.55	Swing frequency falling time	Setting range: 0.00-650.00s	Factory default: 5.00s

The inverter changes output frequency periodically with a predetermined ACC/DEC time when swing frequency runs. This feature is especially useful in the textile industry system in which the speed changes according to the diameter of bobbin.

Swing center frequency comes from given frequency of main and auxiliary channel or the set frequency in multi-speed or PLC running; swing frequency would be automatically canceled in jog and closed-loop running. When PLC and swing frequency run simultaneously, switching between the PLC segment and swing frequency would fail; swing frequency begins after transitioning from PLC deceleration phase to PLC set frequency; press PLC stage ACC/DEC time to decelerate when stop.

While using the swing frequency([F12.49] is valid),inverter ACC to swing center frequency according to ACC/DEC time, and then cycle run according to the swing frequency amplitude [F12.52], startup frequency [F12.53], swing frequency rising time [F12.54] and swing frequency falling time [F12.55] until the stop command by deceleration time.

Swing frequency control

This parameter defines whether use the swing frequency function

0: invalid

1: valid

Swing amplitude control

0: Relative to center frequency: variable,swing amplitude AW changes with the center frequency, the rate of change, see [F12.52] definition.

1: Relative to max frequency:fixed, Amplitude AW is determined by the maximum frequency and [F12.52]

Swing frequency amplitude: This parameter defines the frequency amplitude when in swing frequency control.

Variable Swing: $AW = \text{center frequency} \times [F12.52]$

Fixed Swing: $AW = \text{maximum operating frequency} [F0.09] \times [F12.52]$

Jump swing frequency amplitude: used to set the jump frequency while set the swing frequency running.

Start up frequency= Swing frequency amplitude AW x [F12.53]

Swing frequency rising time: used to set the ACC time of swing frequency.

Swing frequency falling time: used to set the DEC time of swing frequency.

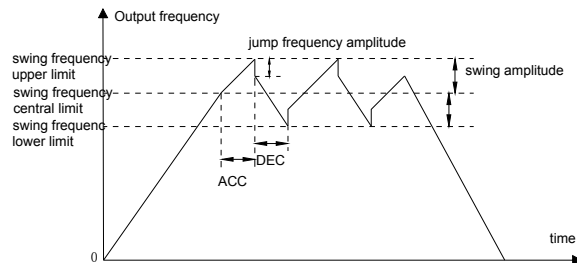

Swing frequency control diagram

8.13 Communication Control Function Parameters

F13.00	Main-slave machine	Setting range: 0000-011	Factory set: 0000
--------	--------------------	-------------------------	-------------------

Choose inverter as main machine or slave machine when Modbus communication or CAN communication. Details for Modbus, refer to Appendix 2:Modbus communication protocol.

LED "0" digit: modbus communication main and slave selection

0: Slave machine Inverter is slave machine. Communication address is decided by [F13.01]. Inverter receives order from main machine and decides whether to reply or not when writing operation according to [F13.08] setting. Reply delay time is set by [F13.05].

1: Main machine Inverter, as main machine, sends data to communication network by broadcast orders. All slave machines accept orders from main machine. The data sending of main machine is set by [F13.09].

LED "00" digit: Can communication master-slave selection

0: slave

1: host

LED "000" digit: reserved
 LED "0000" digit: reserved

Note: When the inverter is used as the host network, all network slaves must also be Flextronics inverters to be properly networked. Broadcast data is sent over a custom free protocol.

F13.01	485 communication address	Setting range: 1-247	Factory set: 1
--------	---------------------------	----------------------	----------------

It set communication address while inverter is Modbus communication slave machine. If inverter is main machine, this parameter is no meaning. 0 is broadcast address.

F13.02	Communication baud rate selections	Setting range: 0000-0065	Factory set: 0003
--------	------------------------------------	--------------------------	-------------------

LED "0" digit: Modbus communication baud rate: set the communication baud rate

- 0: 1200 bps
- 1: 2400 bps
- 2: 4800 bps
- 3: 9600 bps
- 4: 19200 bps
- 5: 38400 bps
- 6: 57600 bps

LED "00" digit: LED ten: Can (VEICHI Can)

- 0: 20 kbps
- 1: 50 kbps
- 2: 100kbps
- 3: 125kbps
- 4: 250kbps
- 5: 500kbps
- 6: 1Mbps

LED "000" digit:Reserved

LED "0000" digit:Reserved

F13.03	Modbus data format	Setting range: 0-5	Factory set: 0
--------	--------------------	--------------------	----------------

Set the data format when Modbus communication. If the data format is different, communication will not be possible.

- 0: (N, 8, 1) no checkout, Data digit: 8, Stop digit: 1
- 1: (E, 8, 1) even checkout, Data digit: 8, Stop digit: 1
- 2: (O, 8, 1) odd checkout, Data digit: 8, Stop digit: 1
- 3: (N,8,2) no checkout,Data digit:8, Stop digit:2
- 4: (E,8,2) even checkout,Data digit:8, Stop digit:2
- 5: (O,8,2) odd checkout,Data digit:8, Stop digit:2

F13.04	Communication ratio setting	Setting range: 0.00-5.00	Factory set: 1.00
--------	-----------------------------	--------------------------	-------------------

The data in communication address 0x2000 or 0x3000of upper machine multiply this parameter is communication giving of this machine. Upper machine communication order can be modified pro rate.

F13.05	Modbus communication answer delay	Setting range: 0.1-100.0s	Factory set: 1.0s
--------	-----------------------------------	---------------------------	-------------------

It defines the intermediate interval between sending data to the upper machine after the data is accepted. While inverter is Modbus communication slave machine,While delay time is shorter than system dealing time, real delay time is same as system dealing time. While delay time is longer than system dealing time, it has to delay while system dealing finished. It does not send data to upper machine until delay time arrive.

This parameter defines the frequency converter as the Modbus communication master station. The delay is the transmission interval of the host, and the internal limit is 2.5 characters.

F13.06	Modbus communication overtime fault time	Setting range: 0.1-100.0s	Factory set: 1.0s
F13.07	Modbus communication fault act mode selections	Setting range: 0-3	Factory set: 1

Modbus communication overtime fault time: If the interval between one communication and next communication is over communication overtime, it is considered as communication break fault. [F13.07] decides the act mode.

LED "0" digit: Modbus communication fault act mode selections

0: No checkout overtime fault No fault checkout.Inverter runs according the last communication command.

1:Alarm and stop freely If it has not received next frame order or the communication order while the latest communication giving order is over [F13.06] time setting, inverter alarms fault E.CE and stops.

2: Alarm, go on running While inverter running command is given by communication,if it has not received the new communication order while the latest communication giving order is over [F13.06] time setting, inverter alarms **10.074** and runs according the last order.

3: Forced stop Frequency inverter stop while communication giving order is over than[F13.06] setting time and does not receive next frame order or other communication order.

LED "00" digit: Reserved

F13.08	Modbus transmission response	Setting range:0-1	Factory set: 0
--------	------------------------------	-------------------	----------------

The parameter chooses whether to respond when the upper machine sends a write command to the drive. If the upper computer needs the reply from the drive, the drive will occupy sharing communication bus; when doing communications control, the upper computer need to retain enough time to reply. If the upper computer does not need a reply message but only send commands to the drive, you can choose no respond to write operation to improve the utilization efficiency of the communication bus. This parameter is valid only for write operation, invalid for read operation.

0: write operation with response

1: write operation without response

F13.09	Modbus main machine sending selections	Setting range: 0000-BBBB	Factory set: 0031
--------	--	--------------------------	-------------------

Set the data that inverter sent the slave machines when inverter is main machine.All slaves will receive the command from the host when the main machine sends broadcast commands.

The host can send four polling data, corresponding to the settings of LED "0" digit, "00" digit,"000" digit and "0000" digit. No data is transmitted when invalid.

LED "0" digit: 1st group of frame selection

- 0: Invalid
- 1: Main machine run command
- 2: Main machine given frequency
- 3: Main machine output frequency
- 4: Main machine upper limit frequency
- 5: Main machine given torque
- 6: Main machine output torque
- 7: Reserved
- 8: Reserved
- 9: Main machine given PID
- A: Main machine feedback PID
- B: Reserved
- C: active current component

- LED "00" digit: 2nd group of frame selection as above
- LED "000" digit: 3rd group of frame selection as above
- LED "0000" digit: 4th group of frame selection as above

Host broadcast data	Corresponding address and application accepted by Slaver
1: running command given	0x3001, Can be used as the data of running command given source 0x01:FWD run 0x02:REV run 0x03:FWD jog 0x04:REV jog 0x05:Stop command (Slave machine stops according stop mode)
2: Main machine given frequency	0x3000, can be used as communication given frequency
3: Main machine output frequency	0x3000, can be used as communication given frequency
4: Main machine upper limit frequency	0x3004, can be used as communication given frequency upper limit
5: Main machine given torque	0x3005, can be used as communication given torque
6: Main machine output torque	0x3005, can be used as communication given torque
7: Reserved	
8: Reserved	
9: Main machine given PID	0x3008, can be used as PID communication given

A: Main machine feedback PID	0x3009, can be used as PID communication given
------------------------------	--

F13.10	RS485 communication port configuration	Setting range: 0-2	Factory default: 0
--------	--	--------------------	--------------------

RS485 communication port configuration

- 0: Modbus communication: general Modbus method
- 1: Serial port monitoring: monitoring inverter running state by upper machine.
- 2: Reserved

F13.16	Expansion port communication disconnection processing	LED "0" digit t: EX-A port disconnection action mode LED "00" digit: EX-B port disconnection action mode 0: no detection 1: alarm and free parking 2: Warning and continue to run	Factory default: 0
--------	---	---	--------------------

LED "0" digit: Set EX-A port disconnection action mode

- 0: no detection
- 1: alarm and free parking
- 2: Warning and continue to run

LED "00" digit: set EX-B port disconnection action mode

- 0: no detection
- 1: alarm and free parking
- 2: Warning and continue to run

F13.17	Expansion port EX-A parameter update	Setting range: 0~2	Factory default: 0
F13.18	Expansion port EX-B parameter update	Setting range: 0~2	Factory default: 0

LED "0" digit: EX-A port disconnection action mode

- 0: no detection
- 1: alarm and free parking
- 2: Warning and continue to run

LED "00" digit: EX-B port disconnection action mode

- 0: no detection
- 1: alarm and free parking
- 2: Warning and continue to run

F13.19	Expansion port EX-A monitoring frame address group 1	Predetermined area: LED digits ten digits: address lower 8 digits 00~63 LED hundred thousand digits: address high 8 digits 00~07	Factory default: 0001
F13.20	Expansion port EX-A monitoring frame address group 2	Setting range: Same as above	Factory default: 0002
F13.21	Expansion port EX-A monitoring frame address group 3	Setting range: Same as above	Factory default: 0007
F13.22	Expansion port EX-A monitoring frame address group	Setting range: Same as above	Factory default: 0011

LED "0" and "00" digits: up and down keys to modify the serial number 00 ~ 99

LED "000" and "0000" digits: up and down keys modify group number 00~15,

For example, set F13.19 to 0001 for C00.01 then do it by that analogy.

F13.23	Expansion port EX-B monitoring frame address group 1	Predetermined area: LED digits ten digits: address lower 8 digits 00~63 LED hundred thousand digits: address high 8 digits 00~07	Factory default: 0001
F13.24	Expansion port EX-B monitoring frame address group 2	Setting range: Same as above	Factory default: 0002
F13.25	Expansion port EX-B monitoring frame address group 3	Setting range: Same as above	Factory default: 0007
F13.26	Expansion port EX-B monitoring frame address group 4	Setting range: Same as above	Factory default: 0011

LED "0" and "00" digits: up and down keys to modify the serial number 00 ~ 99

LED "000" and "0000" digits: up and down keys modify group number 00~15,

For example, set F13.23 to 0001 for C00.01 then do it by that analogy.

Chapter 9 Function Parameter Table

Function parameter profile:

●: Parameter can be changed in the running state.

○: Parameter can't be changed in the running state.

×: Parameter can be read only.

-: Factory setting parameter, only factory can set.

※: Parameter is related to the model.

Basic parameters:

NO.	Function description	Range of settings and definition	Factory default	Feature	Address
F00.00	Motor control mode	Asynchronous motor control mode: 0: V/F control 3: High-performance VC without PG 4: High-performance VC with PG Synchronous motor control mode: 6: High-performance VC without PG 7: VC with PG Other control: 8: Voltage frequency separation output 1/2/5: Reserved	0	○	0x000
F00.01	Reserved				0x001
F00.02	Run command channel	0: Keyboard control 1: Terminal control 2: RS485 communication control 3: Reserved	0	●	0x002
F00.03	Frequency given source channel A	0: Keyboard number given 1: Reserved 2: Voltage/Current analog AI1 given 3: Voltage/Current analog AI2 given 4: Reserved 5: Terminal pulse PUL given 6: RS485 communication given	0	●	0x003
F00.04	Frequency given source channel B	7: Terminal UP/DW control 8: PID control given 9: Program control (PLC) given 10: Optional card 11: Multi-steps speed given	1	●	0x004
F00.05	Frequency channel B reference source	0: Max. output frequency as reference source 1: Set frequency of channel A as reference source	0	●	0x005

F00.06	Frequency given source selection	0: Channel A 1: Channel B 2: Channel A+Channel B 3: Channel A-Channel B 4: Max. value of Channel A and Channel B 5: Min. value of Channel A and Channel B	0	●	0x006
F00.07	Running Command Binding	LED*0"digit: keyboard command instruction binding LED*00"digit: terminal command instruction binding LED*000"digit: communication command instruction binding LED*0000"digit: optional card command instruction binding 0: no binding 1: keyboard number given frequency 2: Reserved 3: Voltage/Current analog AI1 given 4: Voltage/Current analog AI2 given 5: Reserved 6: Terminal pulse PUL given 7: RS485 communication given 8: Terminal UP/DW control 9: PID control given A: Program control (PLC) given B: Optional card C: Multi-steps speed given	0000	●	0x007
F00.08	Keyboard digital setting frequency	0~upper limit	50.00Hz	●	0x008
F00.09	Max frequency	upper limit~600.00Hz	50.00Hz	○	0x009
F00.10	Upper limit frequency source selection	0: Upper limit frequency digital given 1: Reserved 2: Voltage/Current analog AI1 give 3: Voltage/Current analog AI2 given 4: Reserved 5: Terminal pulse PUL given 6: RS485 communication given 7: Optional card	0	●	0x00A
F00.11	Upper frequency limit digital setting	Lower limit frequency~max frequency	50.00Hz	●	0x00B
F00.12	Lower limit	0.00~upper limit frequency	0.00Hz	●	0x00C
F00.13	Lower limit frequency running mode	0: Stop output, enter into pause running state 1: Run at lower limit frequency	1	○	0x00D
F00.14	ACC time 1	0.01~650.00s	Model	※	0x00E
F00.15	DEC time 1	0.01~650.00s	Model	※	0x00F
F00.16	Rotary direction selection	LED*0"digit: running direction takes the opposite 0: Direction unchanged	0000	○	0x010

		1: Direction takes the opposite LED*00"digit: running direction prohibited 0:Forward and reverse commands are allowed 1: Only FWD command allowed 2: Only REV command allowed LED*000"digit: frequency control direction selection 0: Invalid 1: Valid LED*0000"digit: reserved			
F00.17	G/P Model Setting	0: G Type 1: P Type	0	●	0x011
F00.18	Reserved				0x012
F00.19	Parameter initialization	0: No action 1: Restore factory default (not restoring motor parameters) 2: Restore factory default (restoring motor parameters) 3: Clear malfunction records	0	○	0x013

Operation Control Parameters Group

NO.	Function description	Range of settings and definition	Factory setting	Feature	Address
F01.00	Start-up running mode	0: Start by start-up frequency 1: DC Braking at first then start by start-up frequency 2: Speed tracking, and judge the direction then start	0	○	0x100
F01.01	Start pre-excitation time	0.00~60.00s	0.00s	○	0x101
F01.02	Start-up frequency	0.00~60.00Hz	0.50Hz	○	0x102
F01.03	Start-up frequency holding	0.0~50.0s	0.0s	○	0x103
F01.04	Braking current before	0.0~150.0%	60.0%	○	0x104
F01.05	Braking time before start	0.0~60.0s	0.0s	○	0x105
F01.06	Speed tracking time	0.00~60.00s	0.50s	○	0x106
F01.07	Speed tracking delay	0.00~60.00s	1.00s	○	0x107
F01.08	Reserved				
F01.09	Reserved				
F01.10	Stop mode	0:DEC stop 1:Free stop	0	●	0x10A
F01.11	DC braking initial frequency when stop	0.00~50.00Hz	1.00Hz	○	0x10B
F01.12	DC braking current when	0.0~150.0%	60.0%		0x10C
F01.13	Reserved				0x10D
F01.14	DC braking hold time	0.0~60.0s	0.0s	○	0x10E
F01.15	Stop detection frequency	0.00~50.00Hz	0.50Hz	●	0x10F

F01.16	ACC/DEC selection	LED "0" digit: time base selection 0: max frequency 1: fixed frequency 50Hz 2: set frequency LED "00" digit: S ACC/DEC selection 0: Beeline ACC/DEC 1: S Curve ACC/DEC LED "000" digit: reserved LED "0000" digit: reserved	0010	○	0x110
F01.17	ACC start time for S curve	0.00~10.00	0.20s	○	0x111
F01.18	ACC end time for S curve	0.00~10.00	0.20s	○	0x112
F01.19	DEC start time for S curve	0.00~10.00	0.20s	○	0x113
F01.20	DEC end time for S curve	0.00~10.00	0.20s	○	0x114
F01.21	ACC time 2	0.01~650.00s	10.00s	●	0x115
F01.22	DEC time 2	0.01~650.00s	10.00s	●	0x116
F01.23	ACC time 3	0.01~650.00s	10.00s	●	0x117
F01.24	DEC time 3	0.01~650.00s	10.00s	●	0x118
F01.25	ACC time 4	0.01~650.00s	10.00s	●	0x119
F01.26	DEC time 4	0.01~650.00s	10.00s	●	0x11A
F01.27	DEC time at emergency	0.01~650.00s	1.00s	●	0x11B
F01.28	FWD&REV dead time	0.0~120.0s	0.0s	○	0x11C
F01.29	Zero speed torque frequency threshold	0.00~10.00Hz	0.50Hz	●	0x11D
F01.30	Zero speed torque	0.0~150.0%	60.0%	●	0x11E
F01.31	Zero speed torque holding time	0.0~6000.0s If set 6000.0S,always hold without	0	●	0x11F
F01.3- F01.34	Reserved				
F01.35	Power off restart action	0:Invalid 1:Valid	0	○	0x123
F01.36	Power off restart waiting	0.00~60.00s	0.50s	○	0x124
F01.37	Reserved				0x125
F01.38	JOG running frequency	0.00-Max frequency	5.00Hz	●	0x126
F01.39	JOG ACC time	0.01~650.00s	10.00s	●	0x127
F01.40	JOG DEC time	0.01~650.00s	10.00s	●	0x128
F01.41	Jump frequency 1	0.00~Max frequency	0.00Hz	●	0x129
F01.42	Jump frequency range 1	0.00~Max frequency	0.00Hz	●	0x12A
F01.43	Jump frequency 2	0.00~Max frequency	0.00Hz	●	0x12B
F01.44	Jump frequency range 2	0.00~Max frequency	0.00Hz	●	0x12C

Switching value terminal parameters

NO.	Function description	Range of setting and definition	Factory setting	Feature	Address
-----	----------------------	---------------------------------	-----------------	---------	---------

F02.00	Input terminal 1(X1)	Refer to function table 4.2	1	○	0x200
F02.01	Input terminal 2(X2)	Refer to function table 4.2	2	○	0x201
F02.02	Input terminal 3(X3)	Refer to function table 4.2	4	○	0x202
F02.03	Input terminal 4(X4)	Refer to function table 4.2	5	○	0x203
F02.04	Input terminal 5(X5)	Refer to function table 4.2	6	○	0x204
F02.05	Input terminal 6(X6)	Refer to function table 4.2	0	○	0x205
F02.06	Input terminal 7(X7)	Refer to function table 4.2	0	○	0x206
F02.07	Input terminal 8(X8)	Refer to function table 4.2	0	○	0x207
F02.08	Input terminal 9(X9)	Refer to function table 4.2	0	○	0x208
F02.09	Input terminal 10(X10)	Refer to function table 4.2	0	○	0x209
F02.10	X1~X4 terminal trait selection	0: On valid 1: Off valid LED "0" digit: X1 LED "00" digit: X2 LED "000" digit: X3 LED "0000" digit: X4	0000	●	0x20A
F02.11	X5~X8 terminal trait selection	0: On valid 1: Off valid LED "0" digit: X5 LED "00" digit: X6 LED "000" digit: X7 LED "0000" digit: X8	0000	●	0x20B
F02.12	X9~X10 terminal trait selection	0: On valid 1: Off valid LED "0" digit: X9 LED "00" digit: X10 LED "000" digit: Reserved LED "0000" digit: Reserved	0000	●	0x20C
F02.13	X1 valid detection delay	0.000~6.000s	0.010	●	0x20D
F02.14	X1 invalid detection delay	0.000~6.000s	0.010	●	0x20E
F02.15	X2 valid detection delay	0.000~6.000s	0.010	●	0x20F
F02.16	X2 invalid detection delay	0.000~6.000s	0.010	●	0x210
F02.17	X3 valid detection delay	0.000~6.000s	0.010	●	0x211
F02.18	X3 invalid detection delay	0.000~6.000s	0.010	●	0x212
F02.19	X4 valid detection delay	0.000~6.000s	0.010	●	0x213
F02.20	X4 invalid detection delay	0.000~6.000s	0.010	●	0x214
F02.21	X5 valid detection delay	0.000~6.000s	0.010	●	0x215
F02.22	X5 invalid detection delay	0.000~6.000s	0.010	●	0x216
F02.23	Terminal control running mode	0: 2-line 1 1: 2-line 2 2: 3-line 1 3: 3-line 2	0	○	0x217
F02.24	Terminal operate protection	0: OFF 1: ON LED "0" digit: Terminal operate protection when abnormal exit LED "00" digit: Jog terminal operate protection when abnormal exit LED "000" digit: Operate protection when command	0111	○	0x218

		channel switch to terminal			
F02.25	Counter input	0: Common X terminal 1: High speed input terminal PUL 2: PG card counting	0	●	0x219
F02.26	Count input frequency	0~6000	0	●	0x21A
F02.27	PUL signal source	0: X5(max~5 KHz) 1: Extend interface X10	0	○	0x21B
F02.28	PUL input min frequency	0.00~50.00 KHz	0.00kH	●	0x21C
F02.29	PUL min frequency corresponding setting	0.00~100.00%	0.00%	●	0x21D
F02.30	PUL input max frequency	0.00~50.00 KHz	50.00k	●	0x21E
F02.31	PUL max frequency corresponding setting	0.00~100.00%	100.00%	●	0x21F
F02.32	PUL filter time	0.000~9.000s	0.100s	●	0x220
F02.33	PUL cut-off frequency	0.000~1.000 KHz	0.010k	●	0x221
F02.34	UP/DW terminal control mode	0: Off electricity storage 1: Off electricity does not storage 2: Valid in running, clear zero at	0	○	0x222
F02.35	ACC/DEC speed of UP/DW terminal frequency control	0.01~50.00Hz/s	0.50Hz/s	●	0x223
F02.36	Reserved				0x224
F02.37	Timer time unit	0:Second 1:Minute 2:Hour	0	●	0x225
F02.38	Timer setting value	0~65000	0	●	0x226
F02.39	Counter max value	0~65000	1000	●	0x227
F02.40	Counter setting value	0~65000	500	●	0x228
F02.41	Reserved				0x229
F02.42	Output terminal polarity selection	0: Positive 1: Negative LED "0" digit: Terminal Y LED "00" digit: Relay output 1 LED "000" digit: Extended Y1 terminal LED "0000" digit: Extended Relay output 2	0000	●	0x22A
F02.43	Output terminal Y1	Refer to function table 4.2	1	●	0x22B
F02.44	Relay output	Refer to function table 4.2	4	●	0x22C
F02.45	Extend terminal Y1	Refer to function table 4.2			0x22D
F02.46	Extend relay output 2	Refer to function table 4.2			0x22E
F02.47	Y output delay time	0.000~6.000s	0.010s	●	0x22F
F02.48	Extend Y output delay	0.000~6.000s	0.010s	●	0x230
F02.49	Relay 1 output delay time	0.000~6.000s	0.010s	●	0x231
F02.50	Extend relay 2 output	0.000~6.000s	0.010s	●	0x232
F02.51	Output frequency level	0.00~Max. frequency	30.00H	●	0x233
F02.52	FDT1 lag	0.00~Max. frequency	1.00Hz	●	0x234
F02.53	Output frequency level	0.00~Max. frequency	50.00H	●	0x235

F02.54	FDT2 lag	0.00~Max. frequency	1.00Hz	●	0x236
F02.55	Given frequency arriving check-out range	0.00~50.00Hz	2.00Hz	●	0x237
F02.60	Virtual vX1 terminal function selection	Refer to function table 4.2	0	●	0x238
F02.61	Virtual vX2 terminal function selection	Refer to function table 4.2	0	●	0x239
F02.62	Virtual vX3 terminal function selection	Refer to function table 4.2	0	●	0x23A
F02.63	Virtual vX4 terminal function selection	Refer to function table 4.2	0	●	0x23B
F02.64	vX terminal valid state source	0: internal connection with virtual vYn 1: Connect with physical terminal Xn 2: function code setting valid or not LED "0" digit: virtual vX1 LED "000" digit: virtual vX2	0	●	0x23C
F02.65	Virtual vX terminal function code setting valid state	0: invalid 1: valid LED "0" digit: virtual vX1 LED "00" digit: virtual vX2 LED "000" digit: virtual vX3 LED "0000" digit: virtual vX4	0	●	0x23D
F02.66	Virtual vY1 terminal function selection	Refer to function table 4.2	0	●	0x23E
F02.67	Virtual vY2 terminal function selection	Refer to function table 4.2	0	●	0x23F
F02.68	Virtual vY3 terminal function selection	Refer to function table 4.2	0	●	0x240
F02.69	Virtual vY4 terminal function selection	Refer to function table 4.2	0	●	0x241
F02.70	vY1 output delay	0.000~6.000s	0.010	●	0x242
F02.71	vY2 output delay	0.000~6.000s	0.010	●	0x243
F02.72	vY3 output delay	0.000~6.000s	0.010	●	0x244
F02.73	Virtual vY2 output	0.000~6.000s	0.010	●	0x245

Analog Terminal Parameters

NO.	Function description	Range of settings and definition	Factory setting	Feature	Address
F03.00	AI1 Lower limit	0.00~10.00V	0.00V	●	0x300
F03.01	AI1 Lower limit corresponding setting	-100.00~100.00%	0.00%	●	0x301
F03.02	AI1 upper limit	0.00~10.00V	10.00V	●	0x302

F03.03	AI1 upper limit corresponding setting	-100.00~100.00%	100.00 %	●	0x303
F03.04	AI1 filter time	0.000~6.000s	0.010s	●	0x304
F03.05	AI1 zero point loop	0.00~10.00V	0.00V	●	0x305
F03.06	AI2 Lower limit	0.00~10.00V	0.00V	●	0x306
F03.07	AI2 Lower limit corresponding setting	0.00~100.00%	0.00%	●	0x307
F03.08	AI2 upper limit	0.00~10.00V	10.00V	●	0x308
F03.09	AI2 upper limit corresponding setting	0.00~100.00%	100.00 %	●	0x309
F03.10	AI2 filter time	0.000~6.000s	0.010s	●	0x30A
F03.11	AI2 zero point loop	0.00~10.00V	0.00V	●	0x30B
F03.12	AI1 function selection	See X terminal function	0	○	0x30C
F03.13	AI1 high level setting	0.00~100.00%	70.00%	●	0x30D
F03.14	AI1 low level setting	0.00~100.00%	30.00%	●	0x30E
F03.15	AI2 function selection	See X terminal function	0	○	0x30F
F03.16	AI2 high level setting	0.00~100.00%	70.00%	●	0x310
F03.17	AI2 low level setting	0.00~100.00%	30.00%	●	0x311
F03.18	Valid state setting when analog used as terminal	0: low level 1: high level LED "0" digit: AI1 LED "00" digit: AI2 LED "000" digit: reserved LED "0000" digit: reserved	0000	●	0x312
F03.19	Analog input curve selection	LED "0" digit: AI1 0: Beeline (default) 1: curve 1 2: curve 2 LED "00" digit: AI2 (Select voltage or current input by wire jumper) LED "000" digit: reserved LED "0000" digit: reserved	0000	●	0x313
F03.20	Reserved				0x314
F03.21	Curve 1 lower limit	0.00~10.00V	0.00V	●	0x315
F03.22	Curve 1 lower limit corresponding setting	0.00~100.00%	0.0%	●	0x316
F03.23	Curve 1 inflection point 1 input voltage	0.00~10.00V	3.00V	●	0x317
F03.24	Curve 1 inflection point 1 corresponding	0.00~100.00%	30.00%	●	0x318
F03.25	Curve 1 inflection point 2 input voltage	0.00~10.00V	6.00V	●	0x319
F03.26	Curve 1 inflection point 2 corresponding	0.00~100.00%	60.00%	●	0x31A
F03.27	Curve 1 upper limit	0.00~10.00V	10.0V	●	0x31B
F03.28	Curve 1 upper limit corresponding setting	0.00~100.00%	100.00 %	●	0x31C

F03.29	Curve 2 lower limit	0.00~10.00V	0.00V	●	0x31D
F03.30	Curve 2 lower limit corresponding setting	0.00~100.00%	0.00%	●	0x31E
F03.31	Curve 2 inflection point 1 input voltage	0.00~10.00V	3.00V	●	0x31F
F03.32	Curve 2 inflection point 1 corresponding	0.00~100.00%	30.00%	●	0x320
F03.33	Curve 2 inflection point 2 input voltage	0.00~10.00V	6.00V	●	0x321
F03.34	Curve 2 inflection point 2 corresponding	0.00~100.00%	60.00%	●	0x322
F03.35	Curve 2 upper limit	0.00~10.00V	10.00V	●	0x323
F03.36	Curve 2 upper limit corresponding setting	0.00~100.00%	100.00 %	●	0x324
F03.37	A0 output signal selection	LED "0" digit: AO1 0: 0~10V 1: 4.00~20.00mA 2: 0.00~20.00mA 3: FM frequency pulse output LED "00" digit: AO2 extended card 0: 0~10V 1: 4.00~20.00mA 2: 0.00~20.00mA LED "000" digit: reserved LED "0000" digit: reserved	0000	●	0x325
F03.38	A01 output selection	0: Given frequency 1: Output frequency 2: Output current 3: Input voltage 4: Output voltage 5: Machine speed 6: Given torque 7: Output torque 8: PID given value 9: PID feedback value 10: Output power 11: Bus voltage 12: AI1 13: AI2 14: Reserved 15: PUL 16,17: IGBT temperature 1,2 18: RS485 given	0	●	0x326
F03.39	A02 extended output selection	0: Given frequency 1: Output frequency 2: Output current 3: Input voltage 4: Output voltage 5: Machine speed 6: Given torque 7: Output torque 8: PID given value 9: PID feedback value 10: Output power 11: Bus voltage 12: AI1 13: AI2 14: Reserved 15: PUL 16,17: IGBT temperature 1,2 18: RS485 given	1	●	0x327
F03.40	A01 output gain	25.0~200.0%	100.0%	●	0x328
F03.41	A01 analog output signal bias	-10.0%~10.0%	0.0%	●	0x329
F03.42	A01 output filter	0.000~6.000s	0.010s	●	0x32A

F03.43	A01 FM frequency output lower limit	0.00~100.00kHz	0.20kHz	•	0x32B
F03.44	A02FM frequency output upper limit	0.00~100.00kHz	50.00kHz	•	0x32C
F03.45	AO2 extend output	25.0~200.0%	100.0%	•	0x32D
F03.46	A02 extend analog output signal bias	-10.0%~10.0%	0.0%	•	0x32E
F03.47	A02 extend output	0.000~6.000s	0.010s	•	0x32F
F03.48- F03.49	Reserved				

System parameters

NO.	Function description	Range of settings and definition	Factory setting	Feature	Address
F04.00	Parameter and key lock selections	0: Not locked 1: Function parameter locked 2: Function parameter and key locked (except for RUN/STOP/JOG) 3: All function parameter and key locked	0	•	0x400
F04.01	User password	0~65535	0	•	0x401
F04.02-	Reserved				
F04.05	Parameter copy	0: No function 1: Send inverter parameters to keyboard and save 2: Send keyboard parameters to inverter Remaining value: no operation	0	○	0x405
F04.06	Keyboard special function selection	LED "0" digit: (Running command, stop/reset command) 0: Built-in valid, external on valid for stop/reset command 1: External valid, built-in on valid for stop/reset command 2: All valid. Stop/reset command has the highest priority; invalid when FWD/REV valid at the same time LED "00" digit: reserved LED "000" digit: LCD keyboard language selection 0: Chinese 1: English	0000	○	0x406
F04.07	Reserved				0x407

F04.08	STOP key setting	0: Non-keyboard control mode is invalid 1: Non-keyboard control mode stops according to stop mode 2: Non-keyboard control mode stop according to free stop mode	1	○	0x408
F04.09	UP/DOWN key selection	LED "0" digit: keyboard UN/DOWN key modify selection 0: Invalid 1: Modify frequency setting by key board numbers F00.08 2: Modify PID give setting by key board numbers F11.01 LED "00" digit: power off storage selection 0: No save frequency after power off 1: Save frequency after power off LED "000" digit: action limit 0: Operation stop for adjusting 1: Adjusting only in operation, stop for	0011	○	0x409
F04.10- F04.13	Reserved				
F04.14	The display content of the first line in running state	LED "0" and "00" digit: display the first group 00~63 LED "000" and "0000" digit: display the second group 00~63	1101	•	0x40E
F04.15	The display content of the first line in running	Same as above	0402	•	0x40F
F04.16	The display content of the first line in stop	Same as above	1100	•	0x410
F04.17	The display content of the first line in stop	Same as above	0402	•	0x411
F04.18	The display content of the second line in	Same as above	0402	•	0x412
F04.19	The display content of the second line in	Same as above	1210	•	0x413
F04.20	The display content of the second line in stop	Same as above	0402	•	0x414
F04.21	The display content of the second line in stop	Same as above	1210	•	0x415
F04.22	Keyboard display item setting	LED "0" digit: output frequency selection 0: Aim frequency 1: Running frequency LED "000" digit: power display dimension	0000	•	0x416

F04.23	Monitor display selection	LED "0" digit: C00.00-C00.39 0: Normal 1: Debugging LED "00" digit: C00.40-C00.69 0: No display 1: Normal display	0000	•	0x417
F04.24	Rotate speed display coefficient	0.0~500.0%	0000	•	0x418
F04.25	Power display	0.0~500.0%	100.0%	•	0x419
F04.26	Alarm selection 1	LED "0" digit: E.EEP fault (EEPROM storage fault) 0: Alarm and free stop 1: Alarm and continue operation	100.0%	•	0x41A
F04.27	Reserved		0000	○	0x41B
F04.28	Fan control	0:After power on the fan runs 1: Stop associated with temperature, running is rotary 2: Running associated with temperature, stop while the fan stops	1	•	0x41C
F04.29	Energy braking enable	0:Off 1:On	0	•	0x41D
F04.30	Energy braking operation voltage	115.0%~140.0%	125.0%	•	0x41E
F04.31	Energy braking	0.0~100.0%	10.0%	•	0x41F
F04.32	PWM carrier	0.7~16.0kHz	Model	※	0x420
F04.33	PWM control mode	LED "0" digit: carrier associated with temperature 0: Temperature independent 1: Temperature dependent LED "00" digit: carrier associated with output frequency 0: not associated 1: associated LED "000" digit: random PWM valid 0: Prohibited 1: Valid LED "0000" digit: PWM modulation mode 0: Only use three-phase modulation 1: Two-phase and three-phase modulation automatically switched	1111	•	0x421

Motor Parameters

NO.	Function description	Range of settings and definition	Factory default	Feature	Address
F05.00	Motor mode	0: Asynchronous motors (AM) 1: Permanent magnet synchronous	0	×	0x500
F05.01	Number of motor poles	2~98	4	○	0x501
F05.02	Motor rated power	0.1~1000.0kW	Model	※	0x502

F05.03	Motor rated frequency	0.01~max frequency	Model	※	0x503
F05.04	Motor rated speed	1~65000rpm	Model	※	0x504
F05.05	Motor rated voltage	1~1500V	Model	※	0x505
F05.06	Motor rated current	0.1~3000.0A	Model	※	0x506
F05.07	Asynchronous motor no-load current	0.1~3000.0A	Model set	※	0x507
F05.08	Asynchronous motor stator resistance	0.01~50.00%	Model set	※	0x508
F05.09	Asynchronous motor rotor resistance	0.01~50.00%	Model set	※	0x509
F05.10	Asynchronous motor stator leakage	0.01~50.00%	Model set	※	0x50A
F05.11	Asynchronous motor stator inductance	0.1~2000.0%	Model set	※	0x50B
F05.12	synchronous motor stator resistance	0.01~50.00%	Model set	※	0x50C
F05.13	Synchronous machine d axis inductance	0.01~200.00%	Model set	※	0x50D
F05.14	Synchronous machine q axis inductance	0.01~200.00%	Model set	※	0x50E
F05.15	Synchronous machine back EMF	1~1500V	Model set	※	0x50F
F05.16	Synchronous machine encoder installation	0.0°~360.0°	Model set	※	0x510
F05.17	Reserved				
F05.20	Motor parameters self-adjustment selections	0: No operation 1: Rotary type self-tuning 2: Static type self-tuning 3: Stator resistance self-tuning	0	○	0x514
F05.21	Synchronous machine poles searching function	LED "0" digit: closed-loop vector 0: OFF 1: ON 2: On, only operate firstly when electrify LED "00" digit: open-loop vector 0: OFF 1: ON	0010	○	0x515
F05.22	Reserved				

F05.30	Speed feedback or encoder mode	LED "0" digit: encoder mode 0: Common ABZ encoder 1: Resolver encoder LED "00" digit: encoder direction 0: same direction 1: reverse direction LED "000" digit: wire break inspection 0: OFF 1: ON LED "0000" digit: Z pulse correction enabled 0: OFF 1: ON	0000	○	0x51E
F05.31	ABZ encoder lines	0-10000	1024	○	0x51F
F05.32	wire break inspection	0.100-60.000s	2.000s	●	0x520
F05.33	Resolver encoder	2~128	2	○	0x521
F05.34	Numerator of encoder transmission ratio	1~32767	1	○	0x522
F05.35	Denominator of encoder transmission	1~32767	1	○	0x523
F05.36	First-order filter of encoder speed	0.0~100.0ms	1.0ms	●	0x524
F05.37	Reserved				

Motor VC Parameters

NO.	Function description	Range of settings and definition	Factory default	Feature	Address
F06.00	ASR(speed loop) proportional gain 1	0.01~100.00	10.00	●	0x600
F06.01	ASR integral time 1	0.000~6.000s	0.200s	●	0x601
F06.02	ASR filter time1	0.0~100.0ms	0.0ms	●	0x602
F06.03	ASR switch frequency 1	0.00~Max frequency	0.00Hz	●	0x603
F06.04	ASR (speed loop) proportional gain 2	0.01~100.00	10.00	●	0x604
F06.05	ASR (speed loop) integral time 2	0.000~6.000s	0.200s	●	0x605
F06.06	ASR filter time 2	0.0~100.0ms	0.0ms	●	0x606
F06.07	ASR switch frequency 2	0.00~Max frequency	5.00Hz	●	0x607
F06.08	Electric motor torque limit	0.0~250.0%	180.0%	●	0x608
F06.09	Power generation torque	0.0~250.0%	180.0%	●	0x609
F06.10	Current loop D-axis proportional gain	0.001~4.000	1.000	●	0x60A
F06.11	Current loop D-axis integral gain	0.001~4.000	1.000	●	0x60B

F06.12	Current loop Q-axis proportional gain	0.001~4.000	1.000	●	0x60C
F06.13	Current loop Q-axis integral gain	0.001~4.000	1.000	●	0x60D
F06.15	Vector control motor slip compensation	0.0~250.0%	100.0%	●	0x60F
F06.16	Vector control start torque	0.0~250.0%			
F06.17	Reserved		0	○	0x612
F06.18	Position compensation control	0:OFF 1:ON	10.0%	○	0x613
F06.19	compensation gain	0.0~250.0%	0.1%	○	0x614
F06.20	compensation limit	0.0~100.0%	10.0%	○	0x615
F06.21	compensation effective	0.0~100.0%	100.0%	○	0x616
F06.22	Over excitation braking	0.0~500.0%	100.0%	○	0x617
F06.23	Over excitation braking amplitude limit	0.0~250.0%	0	○	0x618
F06.24	Vector control energy saving function	0:OFF 1:ON	50.0%	●	0x619
F06.25	Energy saving control	0.0~80.0%	0.010s	●	0x61A
F06.26	Energy saving control low-pass filter	0.000~6.000s	200.0%	●	0x61B
F06.27	Motor constant power area power limit	0.0~250.0%	60.0%	○	0x61C
F06.28	Motor weak magnetic current upper limit	0.0~250.0%	10.0%	●	0x61D
F06.29	Motor weak magnetic feed forward gain	0.0~200.0%	10.0%	●	0x61E
F06.30	Motor weak magnetic	0.0~500.0%	10.0%	●	0x620
F06.32	MTPA gain	0.0~500.0%	100.0%	●	0x621
F06.33	MTPA filter time	0.0~100.0ms	1.0ms	●	0x621
F06.34	Reserved				0x622
F06.35	Low frequency pull in	0.0~100.0%	10.0%	●	0x623
F06.36	High frequency pull in	0.0~100.0%	10.0%	●	0x624
F06.37	Frequency of current pulled in	0.0~100.0%	10.0%	●	0x625
F06.38-F06.69	Reserved				

Torque Control Parameters

NO.	Function description	Range of settings and definition	Factory default	Feature	Address
F07.00	Torque/Speed control	0:Speed control 1:Torque control Torque/Speed	0	●	0x700

F07.01	Torque given channels selection	0: keyboard number given 1: reserved 2: AI1 3: AI2	4: reserved 5: PUL 6: RS485 communication given 7: Optional card	0	•	0x701
F07.02	Torque keyboard number setting	0~100.0%		0.0%	•	0x702
F07.03	Torque input lower limit	0~100.00%		0.00%	•	0x703
F07.04	Lower limit corresponding setting	-200.00%~200.00%		0.00%	•	0x704
F07.05	Torque input upper limit	0~100.00%		100.00%	•	0x705
F07.06	Upper limit corresponding setting	-200.00%~200.00%		100.00%	•	0x706
F07.07	Given first-order filter time	0.000~6.000S		0.100s	•	0x707
F07.08	Output torque upper limit	0~200.0%		150.0%	•	0x708
F07.09	Output torque lower limit	0~200.0%		0%	•	0x709
F07.10	Torque control FWD speed limit selection	0: function code F07.12setting 1: reserved 2: AI1 × F07.12 3: AI2 × F07.12 4: reserved 5: PUL × F07.12 6: RS485 communication given × F07.12		0	•	0x70A
F07.11	Torque control REV speed limit selection	0: function code F07.13setting 1: reserved 2: AI1 × F07.13 3: AI2 × F07.13 4: reserved 5: PUL × F07.13 6: RS485 communication given × F07.13 7: Optional card × F07.13		0	•	0x70B
F07.12	Torque control FWD max speed limit	0.0~100.0%		100.0%	•	0x70C
F07.13	Torque control REV max speed limit	0.0~100.0%		100.0%	•	0x70D

Motor V/F Control Parameter

NO.	Function description	Range of settings and definition	Factory default	Feature	Address	
F08.00	Linear V/F curve selection	0: Beeline VF curve 1-9: 1.1-1.9 th power VF curve respectively 10: square VF curve 11: self-defined VF curve	0	○	0x800	
F08.01	Self-setting voltage V1	0.0~100.0%	3.0%	○	0x801	
F08.02	Self-setting frequency F01	0.00~max frequency	1.00Hz	○	0x802	
F08.03	Self-setting voltage V2	0.0~100.0%	28.0%	○	0x803	
F08.04	Self-setting frequency F02	0.00~max frequency	10.00Hz	○	0x804	
F08.05	Self-setting voltage V3	0.0~100.0%	55.0%	○	0x805	
F08.06	Self-setting frequency F03	0.00~max frequency	25.00Hz	○	0x806	
F08.07	Self-setting voltage V4	0.0~100.0%	78.0%	○	0x807	
F08.08	Self-setting frequency F04	0.00~max frequency	37.50Hz	○	0x808	
F08.09	Self-setting voltage V5	0.0~100.0%	100.0%	○	0x809	
F08.10	Self-setting frequency F05	0.00~max frequency	50.00Hz	○	0x80A	
F08.11	Output voltage percentage	25.0~120.0%	100.0%	○	0x80B	
F08.12	Torque boost	0.0~30.0%	0.0%	•	0x80C	
F08.13	Torque boost cut-off frequency	0.0~100.0%	100.0%	•	0x80D	
F08.14	Slip compensation gain	0.0~200.0%	100.0%	•	0x80E	
F08.15	Slip compensation limit	0.0~300.0%	100.0%	•	0x80F	
F08.16	Slip compensation filter	0.000~6.000s	0.200s	•	0x810	
F08.17	oscillation suppression	0.0~900.0%	100.0%	•	0x811	
F08.19	Auto energy saving control	0: off 1: on	0	○	0x813	
F08.20	Energy saving lower limit frequency	0.0~50.00Hz	15.00Hz	○	0x814	
F08.21	Energy saving lower limit voltage	20.0~100.0%	50.0%	○	0x815	
F08.22	Energy saving regulation rate of voltage	0.000~0.200V/MS	0.010V/MS	•	0x816	
F08.23	Energy saving recovery rate of voltage	0.000~2.000V/MS	0.200V/MS	•	0x817	
F08.24- F08.29	Reserved					
F08.30	Output voltage source of voltage-frequency separation	0: function code F8.31 setting 1: Reserved 2: AI1 3: AI2	4: Reserved 5: PUL 6: PID output 7: RS485 8: Optional	0	•	0x81E

F08.31	Output voltage source of voltage-frequency separation number setting	0.0%~100.0%	0.0%	•	0x81F
F08.32	Output voltage source of voltage-frequency separation ACC time	0.0~100.00s	10.00s	•	0x820
F08.33	Output voltage source of voltage-frequency separation DEC time	0.0~100.00s	10.00s	•	0x821
F08.34	voltage-frequency separation stop time	0:Output voltage and frequency ACC/DEC no interaction 1: Output voltage down to 0V, then output frequency start to	0	•	0x822

Protection and Malfunction Parameter Group

NO.	Function description	Range of settings and definition	Factory default	Feature	Address
F10.00	OC suppression function	0: Suppression valid 1: ACC/DEC valid, constant speed	0	•	0xA00
F10.01	OC suppression point	0.0~300.0%	160.0%	•	0xA01
F10.02	OC suppression gain	0.0~500.0%	100.0%	•	0xA02
F10.03	Current hardware protection settings	LED "0" digit: CBC(cycle by cycle, limit current according to its waveform) 0: off 1: on LED"00" digit: OC protection interference suppression 0: off 1: First grade 2: Second grade LED"000"digit: SC protection interference suppression 0: off 1: First grade 2: Second grade LED"0000"digit: Reserved	0001	○	0xA03
F10.04	Reserved				0xA04
F10.05	Hardware protection	0: Invalid 1: Valid			0xA05
F10.06	Bus over voltage suppression function	LED"0" digit: Over voltage suppression 0: Invalid 1: Valid in DEC 2: Valid both in ACC/DEC LED"00" digit: Over-excitation control 0: off 1: on LED"000"/"0000": Reserved	0012	○	0xA06

F10.07	Bus over voltage suppression point	110.0~150.0%	128.0%	※	0xA07
F10.08	Bus over voltage suppression gain	0.0~500.0%	100.0%	•	0xA08
F10.09	Bus under voltage suppression function	0: Invalid 1: Valid	0	○	0xA09
F10.10	Bus under voltage suppression point	60.0~90.0%	80.0%	※	0xA0A
F10.11	Bus under voltage suppression gain	0.0~500.0%	100.0%	•	0xA0B
F10.12	Bus under voltage protection point	60.0~90.0%	60.0%	※	0xA0C
F10.13	Phase missing	0~100%	10.0	○	0xA0D
F10.14	Short-circuit detection after power on	LED "0" digit: Earth short-circuit detection after power on 0: off 1: on LED"00" digit: Fan short-circuit detection after power 0: off 1: on	11	○	0xA0E
F10.15	phase missing protection	LED"0" digit: Output phase missing protection 0: off 1: on LED"00" digit: Input phase missing protection 0: off 1: Open Alarm 2: Open Fault(STOP VFD) LED"000"/"0000" digit: Reserved	0021	○	0xA0F
F10.16	Motor overload protection curve	0.0~250.0%	100.0%	○	0xA10

F10.17	Load pre alarm detection setting	LED "0" digit: Detection selection(Protection 1) 0: Not detection 1: Detected load is too large 2: Detected load is too large only at constant speed 3: Detected underloaded 4: Detected underloaded only at constant speed LED "00" digit: Alarm selection 0: alarm and continue operation 1: Fault protection and free stop LED "000" digit: Detection selection (Protection 2) 0: Not detection 1: Detected load is too large 2: Detected load is too large only at constant speed 3: Detected underloaded 4: Detected underloaded only at constant speed	0000	○	0xA11
F10.18	Pre alarm detection level 1 for load	0.0~200.0%	130.0%	○	0xA12
F10.19	Load pre alarm detection time 1	0.0~60.0s	5.0s	○	0xA13
F10.20	Pre alarm detection level 2 for load	.0~200.0%	30.0%	○	0xA14
F10.21	Load pre alarm detection time 2	0.0~60.0s	5.0s	○	0xA15
F10.22	Reserved				0xA16
F10.23	Protection action of speed bias excess	LED "0" digit: Detection selection 0: Not detected 1: Detected only at constant speed 2: Detecting LED "00" digit: Alarm selection 0: Free stop and report fault 1: Alarm and continue operation LED "000"/"0000" digit: Reserved	0000	○	0xA17
F10.24	Detection threshold when speed bias	0.0~60.0%	10.0%	○	0xA18
F10.25	Detection time when speed bias excess	0.0~60.0s	2.0s	○	0xA19

F10.26	Stall protection action	LED "0" digit: Detection selection 0: Not detected 1: Detected at constant speed 2: Detecting LED "00" digit: Alarm selection 0: Free stop and report fault 1: Alarm and continue operation LED "000" digit: Reserved LED "0000" digit: Reserved	0000	○	0xA1A
F10.27	Stall detection	0.0~150.0%	110.0%	○	0xA1B
F10.28	Stall detection time	0.000~2.000s	0.010s	○	0xA1C
F10.29	Motor overshoot Protection threshold	0~200°C		○	0xA1D
F10.30	Motor overshoot Pre alarm threshold	0~200°C		○	0xA1E
F10.31-F10.37	Reserved				
F10.38	Malfunction self-recovery times	0~5	0	○	0xA26
F10.39	Malfunction self-recovery interval	0.1~100.0s	1.0s	○	0xA27

PID Process Control Parameter Group

NO.	Function description	Range of settings and definition	Factory default	Feature	Address
F11.00	PID Controller given signal source	0: Keypad digit PID given 1: Reserved 2: AI1 3: AI2 4: Reserved 5: PUL 6: RS485 7: Option card 8: Terminal selection	0	●	0xB00
F11.01	Keyboard digit PID given / feedback	0.00~100.0%	50.0%	●	0xB01
F11.02	PID given changing	0.00~60.00s	1.00s	●	0xB02
F11.03	PID controller feedback signal source	0: Keypad digital PID feedback 1: Reserved 2: AI1 3: AI2 4: Reserved 5: PUL 6: RS485 7: Option card 8: Terminal selection	2	●	0xB03
F11.04	Feedback signal filter	0.000~6.000s	0.010s	●	0xB04
F11.05	Feedback signal gain	0.00~10.00	1.00	●	0xB05
F11.06	Given and feedback	0~100.0	100.0	●	0xB06

F11.07	PID control selection	LED"0" digit: Feedback feature selection 0: Positive feature 1: Negative feature LED"00"/"000" digit: Reserved LED"0000" digit: Differential adjustment properties 0: Differential bias 1: Differential of feedback	0100	•	0xB07
F11.08	PID preset output	0.0~100.0%	100.0%	•	0xB08
F11.09	PID preset output running time	0.0~6500.0s	0.0s	•	0xB09
F11.10	PID control deviation	0.0~100.0%	0.0%	•	0xB0A
F11.11	Proportional gain P1	0.000~8.000	0.100	•	0xB0B
F11.12	Integral time I1	0.0~600.0s	1.0s	•	0xB0C
F11.13	Differential time D1	0.000~6.000s	0.000s	•	0xB0D
F11.14	Proportional gain P2	0.000~8.000	0.100	•	0xB0E
F11.15	Integral time I2	0.0~600.0s	1.0s	•	0xB0F
F11.16	Differential gain D2	0.000~6.000s	0.000s	•	0xB10
F11.17	PID Parameter switching condition	0: No switch 1: Use DI terminal to switch 2: Switch according to deviation	0	•	0xB11
F11.18	Low value of switching deviation	0.0~100.0%	20.0%	•	0xB12
F11.19	High value of switching deviation	0.0~100.0%	80.0%	•	0xB13
F11.20	Reserved				0xB14
F11.21	Differential limit	0.0~100.0%	5.0%	•	0xB15
F11.22	PID output upper limit	0.0~100.0%	100.0%	•	0xB16
F11.23	PID output lower limit	-100.0~F11.19	0.0%	•	0xB17
F11.24	PID output filter time	0.000~6.000s	0.000s	•	0xB18
F11.25	Feedback wire break detection time	0.0~120.0s	1.0s	•	0xB19
F11.26	Feedback wire break action selection	0: Go on PID operation without alarm 1: Stop and alarm malfunction 2: continue to PID operation and output alarm signal 3: Run at the current frequency and output alarm signal	0	•	0xB1A
F11.27	Wire break alarm	0.0~100.0%	100.0%	•	0xB1B
F11.28	Wire break alarm	0.0~100.0%	0.0%	•	0xB1C
F11.29	Close-loop suspend detection threshold	0.0~100.0%	0.0%	•	0xB1D
F11.30	Close-loop suspend detection time	0.0~600.0s	1.0s	•	0xB1E

Multi-Speed and PLC Function Parameter Group

NO.	Function description	Range of setting and definition	Factory default	Feature	Address
F12.00	PLC Speed 1	0.00~Max frequency	10.00Hz	•	0xC00
F12.01	PLC Speed 2	0.00~Max frequency	20.00Hz	•	0xC01
F12.02	PLC Speed 3	0.00~Max frequency	30.00Hz	•	0xC02
F12.03	PLC Speed 4	0.00~Max frequency	40.00Hz	•	0xC03
F12.04	PLC Speed 5	0.00~Max frequency	50.00Hz	•	0xC04
F12.05	PLC Speed 6	0.00~Max frequency	40.00Hz	•	0xC05
F12.06	PLC Speed 7	0.00~Max frequency	30.00Hz	•	0xC06
F12.23	PLC Speed 8	0.00~Max frequency	20.00Hz	•	0xC07
F12.08	PLC Speed 9	0.00~Max frequency	10.00Hz	•	0xC08
F12.09	PLC Speed 10	0.00~Max frequency	20.00Hz	•	0xC09
F12.10	PLC Speed 11	0.00~Max frequency	30.00Hz	•	0xC0A
F12.11	PLC Speed 12	0.00~Max frequency	40.00Hz	•	0xC0B
F12.12	PLC Speed 13	0.00~Max frequency	50.00Hz	•	0xC0C
F12.13	PLC Speed 14	0.00~Max frequency	40.00Hz	•	0xC0D
F12.14	PLC Speed 15	0.00~Max frequency	30.00Hz	•	0xC0E
F12.15	PLC Running mode selection	LED"0" digit: cycle mode 0: Stop after single cycle 1: Continuous cycles 2: Keep final value after single cycle LED"00" digit: Time unit 0: second 1: minute 2: hour LED"000" digit: Power down memory 0: Not save 1: save LED"0000" digit: Start mode 0: Restart from the 1st stage 1: Restart from the stop stage 2: Continue running from the time when stop	0000	•	0xC0F
F12.16	PLC 1st step running	0.0~6500.0(s/m/h)	10.0	•	0xC10
F12.17	PLC 2nd step running	0.0~6500.0(s/m/h)	10.0	•	0xC11
F12.18	PLC 3rd step running	0.0~6500.0(s/m/h)	10.0	•	0xC12
F12.19	PLC 4thstep running time	0.0~6500.0(s/m/h)	10.0	•	0xC13
F12.20	PLC 5th step running	0.0~6500.0(s/m/h)	10.0	•	0xC14
F12.21	PLC 6th step running	0.0~6500.0(s/m/h)	10.0	•	0xC15
F12.22	PLC 7th step running	0.0~6500.0(s/m/h)	10.0	•	0xC16
F12.23	PLC 8th step running	0.0~6500.0(s/m/h)	10.0	•	0xC17
F12.24	PLC 9th step running	0.0~6500.0(s/m/h)	10.0	•	0xC18
F12.25	PLC 10th step running	0.0~6500.0(s/m/h)	10.0	•	0xC19
F12.26	PLC 11th step running	0.0~6500.0(s/m/h)	10.0	•	0xC1A

F12.27	PLC 12th step running	0.0~6500.0(s/m/h)	10.0	●	0xC1B
F12.28	PLC 13th step running	0.0~6500.0(s/m/h)	10.0	●	0xC1C
F12.29	PLC 14th step running	0.0~6500.0(s/m/h)	10.0	●	0xC1D
F12.30	PLC 15th step running	0.0~6500.0(s/m/h)	10.0	●	0xC1E
F12.31	PLC 1st-15th step direction and ADD/DEC time	LED"0" digit: current step run direction 0: FWD 1: REV LED"00" digit: ACC/DEC time in this step 0: ACC/DEC time 1 1: ACC/DEC time 2 2: ACC/DEC time 3 3: ACC/DEC time 4 LED"000" digit: Reserved LED"0000" digit: Reserved	0000	●	0xC1F
F12.32			0000	●	0xC20
F12.33			0000	●	0xC21
F12.34			0000	●	0xC22
F12.35			0000	●	0xC23
F12.36			0000	●	0xC24
F12.37			0000	●	0xC25
F12.38			0000	●	0xC26
F12.39			0000	●	0xC27
F12.40			0000	●	0xC28
F12.41			0000	●	0xC29
F12.42			0000	●	0xC2A
F12.43			0000	●	0xC2B
F12.44			0000	●	0xC2C
F12.45			0000	●	0xC2D
F12.46	Reserved				
F12.49	Swing frequency control	0: invalid 1: valid	0	●	0xC31
F12.50	Swing frequency amplitude	0: Relative to central frequency 1: Relative to max frequency	0	●	0xC32
F12.51	Reserved	0.0~100.0%	10.0%	●	0xC34
F12.52	Swing frequency				
F12.53	Jump frequency	0.0~50.0%	10.0%	●	
F12.54	Swing frequency rising	0.00~650.00s	5.00s	●	0xC36
F12.55	Swing frequency falling	0.00~650.00s	5.00s	●	0xC37

Communication Control Function Parameter Group

NO.	Function description	Range of setting and definition	Factory default	Feature	Address
F13.0 0	Main-slave machine selection	LED "0" digit: Modbus main-slave selection 0: Slave machine 1: Main machine	0000	○	0xD00
F13.0	485 communication	1~247	1	○	0xD01
F13.0 2	Communication baud rate selection	LED"0" digit:485 communication 0:1200 bps 1:2400 bps 2:4800 bps 3:9600 bps 4:19200 bps 5:38400 bps LED "00" /"000"/"0000" digit: reserved	0003	○	0xD02

F13.0 3	Modbus data format	0: (N,8,1)/format 1: (E,8,1) 3: (N,8,2) format 4: (E,8,2) format 5: (O,8,2)	0	○	0xD03
F13.0	Communication ratio	0.00~5.00	1.00	●	0xD04
F13.0 5	Modbus communication answer delay	0~500ms	0ms	●	0xD05
F13.0 6	Modbus communication overtime fault time	0.1~100.0s	1.0s	●	0xD06
F13.0 7	Modbus communication fault action mode selection	0: No checked overtime fault 1: alarm and stop freely 2: Alarm and continue running 3: Forced stop	0	●	0xD07
F13.0 8	Modbus Responds dispose	0:Write operation with response 1: Write operation without response	0	●	0xD08
F13.0 9	Main machine sending selection	LED"0"digit: the first group transmitting frame selection 0: Invalid 1: Main machine run command 2: Main machine given frequency 3: Main machine output frequency 4: Main machine upper limit frequency 5: Main machine given torque 6: Main machine output torque 7/8: Reserved 9: Main machine given PID A: Main machine feedback PID LED"00" digit: the second group transmitting frame selection LED"000" digit: the third group transmitting frame selection LED"0000" digit: the fourth group transmitting frame selection Same as above	0031	●	0xD09
F13.1 0	RS485 Communication port configuration	0: Modbus communication 1: serial port communication	0	●	0xD0A

Terminal of Input and Output Function Selection

X	Function Specification	X	Function Specification	X	Function
0	No function	16-1	Multispeed terminal 1-4	41	Timer clear terminal
1	FWD	20	PID control cancel	42	Counter input
2	REV	21	PID control pause	43	Counter clear
3	3-line running(X)	22	PID trait switch	44	DC braking
4	FWD JOG	23	PID gain switch	45	Pre excitation

5	REV JOG	24-26	PID given switch 1-3	48	Command channel switch to keyboard
6	Free stop	27-29	PID feedback switch1-3	49	Command channel switch to terminal
7	Emergency stop	30	PLC pause	50	Command channel switch to
8	Malfunction reset	31	PLC restart	51	Command channel switch to expansion
9	External malfunction input	32	ACC/DEC time selection	52	Operation banned
1	Frequency UP	33	ACC/DEC time selection	53	Forward banned
11	Frequency DW	34	ACC/DEC pause	54	Reverse banned
1	UP/DW clear	35	Swing frequency input	60	Speed torque control
1	Switch channel A to channel	36	Swing frequency	61	Position control
1	Channel combination switch	37	Swing frequency reset	No Definition Code:38-39,46-47, 55-59:Reserved	
1	Channel combination switch	40	Timer trigger terminal		
Y	Function Specification	Y	Function Specification	Y	Function
0	No output	1	FWD running	2	REV running
3	FWD running	4	Fault warning 1.enable output including fault reset auto period	5	Fault trip alarm 2(no alarm when fault self-recovery)
6	External fault stop	7	External fault stop Under voltage	8	Finish ready for running
9	Output frequency level detection 1(FDT1)	10	Output frequency level detection 2(FDT2)	11	Reach given frequency
1	0 speed running	13	Reach upper limit	14	Reach lower
1	Program running circle completed	16	Program running segment completed	17	PID feedback exceeds upper limit
1	PID feedback under lower	19	PID feedback sensor wires	21	Timer time arrived
2	Counter reaching max value	23	Counter reach set value	24	Braking
2	PG feedback wire break	26	Emergency stop	27	Load pre-alarm
2	Load pre-alarm output 2	29	Reserved	30	RS485 given

Monitor Code

Access 'C' parameter group by pressing 'PRG' for more than 2s; check the current state of VFD

1. C00-Basic Parameter Monitor Group:

Function	Function name	Unit and definition	Address	Function Code	Function name	Unit and definition	Address
C00.00	Given frequency	0.01Hz	0x2100	C00.20	Analog output AO1	0.01V/0.01mA/0.01kHz	0x2114
C00.01	Output frequency	0.01Hz	0x2101	C00.21	Analog output AO2(extend)	0.01V/0.01mA/0.01kHz	0x2115

C00.02	Output current	0.1A	0x2102	C00.22	Counting value of counter		0x2116
C00.03	Input voltage	0.1V	0x2103	C00.23	Running time after power on	0.1 hour	0x2117
C00.04	Output voltage	0.1V	0x2104	C00.24	Local accumulative running time	hour	0x2118
C00.05	Machine speed	1RPM	0x2105	C00.25	VFD power level	kW	0x2119
C00.06	Given torque	0.1%	0x2106	C00.26	VFD rated voltage	V	0x211A
C00.07	Output torque	0.1%	0x2107	C00.27	VFD rated current	A	0x211B
C00.08	PID given value	0.1%	0x2108	C00.28	Software version		0x211C
C00.09	PID feedback value	0.1%	0x2109	C00.29	PG feedback frequency	0.01Hz	0x211D
C00.10	Output power	0.1%	0x210A	C00.30	Counted time of timer	sec/min/hour	0x211E
C00.11	Bus voltage	0.1V	0x210B	C00.31	PID output value	0.00%	0x211F
C00.12	Module temperature 1	0.1°C	0x210C	C00.32	Software sub-version		0x2120
C00.13	Module temperature 2	0.1°C	0x210D	C00.33	Encoder angle	0.1°	0x2121
C00.14	Input terminal X on state	See input terminal diagram	0x210E	C00.34	Encoder deviation accumulative	1	0x2122
C00.15	Output terminal Y on state	See output terminal diagram	0x210F	C00.35	Encoder Z signal pulse count	1	0x2123
C00.16	Analog AI1 input value	0.001V/0.001mA	0x2110	C00.36	Fault pre alarm code	1	0x2124
C00.17	Analog AI2 input value	0.001V/0.001mA	0x2111	C00.37	Total power consumption (low bit)	1°	0x2125
C00.18	Reserved		0x2112	C00.38	Total power consumption (high bit)	10000°	0x2126
C00.19	Pulse input value of PUL port	0.001kHz	0x2113	C00.39	Power factor angle	1°	0x2127

2. C01-Malfunction Diagnosis Monitor Group

Function code	Function name	Unit and definition	Addresses
C01.00	Malfunction types	See fault code table	0x2200
C01.01	Malfunction diagnosis information	See fault code table	0x2201
C01.02	Malfunction running frequency	0.00~Max frequency	0x2202
C01.03	Malfunction output Voltage	0~1500V	0x2203
C01.04	Malfunction out Current	0.1~1000.0A	0x2204
C01.05	Malfunction Bus Voltage	0~3000V	0x2205
C01.06	Malfunction module temperature	0~100℃	0x2206
C01.07	Malfunction machine state	LED "0" digit: Running direction 0: FWD 1: REV LED "00" digit: Running status 0: Stop 1: ACC 2: DEC 3: Constant speed LED "000" digit: Reserved LED "0000" digit: Reserved	0x2207
C01.08	Malfunction input terminal status	See input terminal chart	0x2208
C01.09	Malfunction output terminal status	See output terminal chart	0x2209
C01.10	The last malfunction types	Please see malfunction code table	0x220A
C01.11	The first diagnosis information	Please see malfunction code table	0x220B
C01.12	The last malfunction running frequency	0.00~Maxfrequency	0x220C
C01.13	The last malfunction output voltage	0~1500V	0x220D
C01.14	The last malfunction output current	0.1~2000.0A	0x220E
C01.15	The last malfunction bus voltage	0~3000V	0x220F
C01.16	The last malfunction module	0~100℃	0x2210
C01.17	The last malfunction machine state	LED "0" digit: Running direction 0: FWD 1: REV LED "00" digit: Running status 0: Stop 1: Constant speed 2: ACC 3: DEC LED "000" digit: Reserved LED "0000" digit: Reserved	0x2211
C01.18	The last malfunction input terminal	See input terminal chart	0x2212
C01.19	The last malfunction output terminal	See output terminal chart	0x2213
C01.20	The first two malfunction types	Please see malfunction information code table	0x2214
C01.21	The first two diagnosis information		0x2215
C01.22	The first three malfunction types		0x2216
C01.23	The first three diagnosis information		0x2217

Appendix 1: AC300 IO Expansion Card Manual

1. AC300IO Expansion Card Introduction

The AC300 inverter has a powerful expansion functions. The AC300IO1 expansion card is a terminal expansion card that can be used in our AC300 full range of inverters. Enriched the input and output terminal functions of the inverter can meet the needs of various applications in specific situations.

2. AC300IO Card Ordering Model

Product order model: AC300IO1

3. AC300IO Expansion Card Instructions

- Product technical parameters

Category	Digital input signal characteristics			
	Signal name	Response frequency range	input resistance	Effective level range
Input signal	X6,X7,X8,X9	0-50KHz	About 4.4 KΩ	High level: 10V~30V
	X10	0-50KHz	About 1.5 KΩ	Low level: 0V~8V

Category	Digital output signal characteristics		
	Signal name	output method	Maximum output
Output signal	Y2	NPN collective tube open collector output	DC24V/50mA
	TA2,TB2,TC2	Relay normally open normally closed output	3A/240VAC

Category	PT100 thermocouple analog input signal characteristics		
	Signal name	output method	Detection temperature range
PT100 Signal	PK+/PK-	Differential two-wire input	0℃-200℃

- Terminal Function Introduction

The AC300IO1 expansion card terminal arrangement is shown in the following figure:

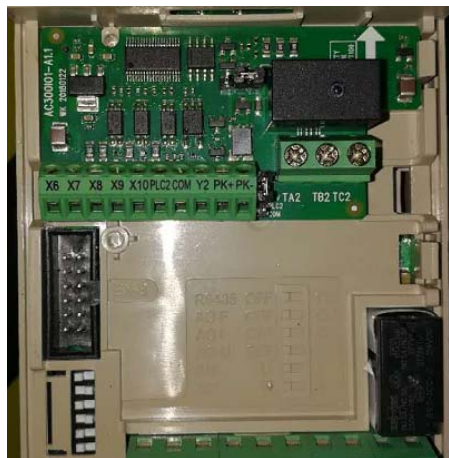

Signal Terminal Function Description

Terminal definition	Terminal name	Description
Digital input terminal	X6	Digital switching input terminal
	X7	Digital switching input terminal
	X8	Digital switching input terminal
	X9	Digital switching input terminal
	X10	Digital switching input terminal
Common terminal	COM	Digital switch input and output reference ground terminal
	PLC2	PLC2 wiring common terminal (can be connected to 24V or COM by jumper)
Digital output terminal	Y2	Digital switching output terminal, maximum output DC24V/50mA
	TA2	Relay output terminal
	TB2	Relay output terminal
Motor temperature sensor input terminal	TC2	Relay output terminal
	PK+	PT100 temperature sensor input +
	PK-	PT100 temperature sensor input -

178

- Select Terminal Function Description

The jumper switch is shown in the table below:

Switch Definition	Gear Name	Description
S7	+24V	+24V external power supply, maximum output 100mA current
	PLC2	PLC terminal block, optional +24V or COM
	COM	+24V power reference point (output open collector signal reference point)
J6	KTY	KTY84 temperature sensor
	PK	PK is shorted to PT100, select PT100 temperature sensor type input
	PT100	PT100 temperature sensor

Note: The S7 factory setting is dialed to the top, that is, PLC2 selects to receive +24V gear position, J6 factory setting dials to the right PT100 gear position, selects PT100 temperature sensor type input, currently only supports PT100 thermocouple, KTY84, PT1000 type thermocouple follow-up roll out.

- Wiring Precautions

The AC300 expansion card terminal signal line should be separated from the power line to avoid crosstalk between strong and weak electrical signals.

- Related parameter settings

Set the relevant parameters of the inverter according to the actual use. Specifically related to the following parameters:

Function code number	Function code name
F02.05-F2.09	Multi-function input terminal 6~10
F02.27	PUL port source
F02.44	Extended output Y1 terminal
F02.46	Extended relay output 2
F10.29	Motor overheat protection selection (extended)
F10.30	Motor overheat alarm level (extended)
F10.31	Motor overheat warning level (extended)
F13.16	Expansion port communication disconnection processing

179

4. Installation and size

- Installation Schematic

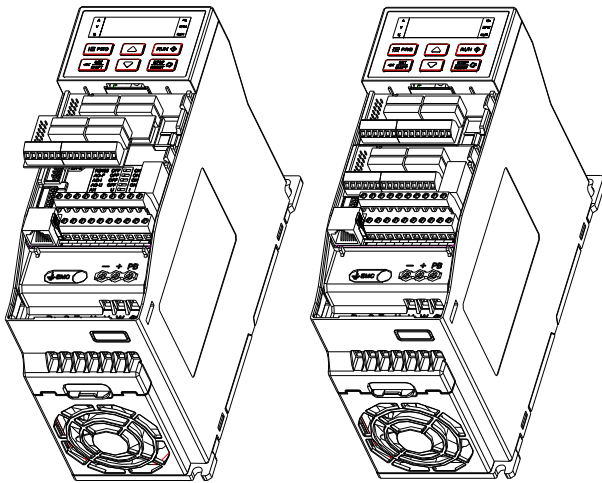

- Board size chart:

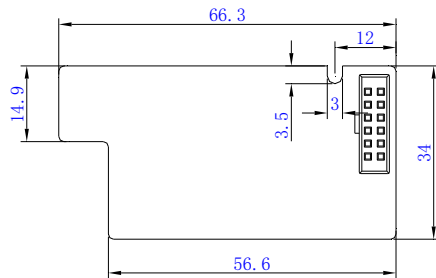

Appendix 2 : PG Card Manual

Introduction to AC300-PG01

The AC300 universal inverter has a wealth of powerful expansion functions. The AC300-PG01 expansion card is a PG feedback expansion card that can be used in our AC300 full range of inverters. Supports maximum frequency 500KHz differential input with input signal disconnection detection. Support differential, transistor open collector two ways of output.

AC300-PG01 card ordering model

Product order model: AC300-PG01

AC300-PG01 expansion card instructions

- Product technical parameters:

Category	Encoder feedback input signal characteristics (differential)			
	Signal name	Response frequency range	input resistance	Effective level range
Input signal	A+, A-	0-500KHz	136Ω	positive: -2.3V~-5.5V negative: +2.3V~-5.5V
	B+, B-	0-500KHz	136Ω	positive: -2.3V~-5.5V negative: +2.3V~-5.5V
	Z+, Z-	0-500KHz	136Ω	positive: -2.3V~-5.5V negative: +2.3V~-5.5V

Category	PG card output signal characteristics (1)		
	Signal name	output method	Maximum output
Output signal	OA+, COM	NPN open collector output	500KHz/100mA
	OB+, COM	NPN open collector output	500KHz/100mA

Category	PG card output signal characteristics (2)		
	Signal name	output method	Maximum output
Output signal	OA+, OA-	Differential output	500KHz/20 mA
	OB+, OB-	Differential output	500KHz/20 mA

Category	VCC power index		
	Signal name	Voltage amplitude	Maximum load
Output signal	VCC、GND	+5V	200mA

Terminal function introduction

AC300-PG01 expansion card terminal arrangement as shown below:

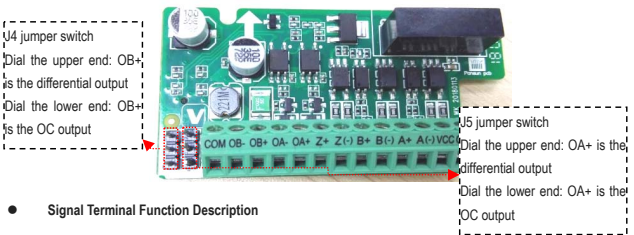

Signal Terminal Function Description

Terminal definition	Terminal name	Description
Encoder signal and power terminal	A+, A-	Encoder A phase feedback input signal
	B+, B-	Encoder B phase feedback input signal
	Z+, Z-	Encoder Z phase feedback input signal
	VCC	Encoder power +, +5V
	GND	Encoder power -, 0V
PG card signal output terminal	OA+, OA-	PG card A phase signal output (differential, OC)
	OB+, OB-	PG card B phase signal output (differential, OC)
	COM	Reference ground when OC signal is output

Select Terminal Function Description

Please refer to the above figure for the specific schematic diagram; the jumper switch is shown in the table below:

Switch Definition	Gear Name	Description
J4 (By the edge of the board)	OB_D	OB+ is selected as differential signal output (jump above)
	OB+	Common signal terminal, selectable differential signal, OC signal
	OB_C	OB+ is selected as OC signal output (skip down)
J5 (By terminal)	OA_D	OA+ is selected as differential signal output (upper end)
	OA+	Common signal terminal, selectable differential signal, OC signal
	OA_C	OA+ is selected as OC signal output (jump below)

Note: J4 factory setting is dialed above, ie OB+ selects differential output;
The factory setting of J5 is set to the top, that is, OA+ selects the differential output;

Wiring Precautions

- The signal line of the AC300-PG01 terminal should be separated from the power line. Parallel routing should be prohibited to avoid crosstalk between strong and weak electrical signals.
- To avoid interference from the encoder signal, please use shielded cable as the PG card signal cable.
- The shield of the encoder shielded cable should be grounded (extension card PE end) and must be single-ended grounded to avoid signal interference.
- PG card crossover output If the external user power supply, the voltage should be less than 24V, otherwise the PG card will be damaged.
- Recommended twisted pair cable specifications and wiring length

Input and output signal type	Wiring length	Cable specification
Drive type	100M	0.2-0.8 mm ² AWG24-AWG18 Internal resistance is less than 6Ω
Voltage type	50m	
Collector type	50m	

Related parameter settings

Set the relevant parameters of the inverter according to the actual use. After the setting is completed, the motor rotation self-learning is required. Specifically related to the following parameters:

Function code number	Function code name	instruction manual
F00.00	Motor control mode	Select PG high performance vector control
F05.01	Number of motor stages	Set the actual number of stages of the motor
F05.02	Motor rated power	Set the motor rated power
F05.03	Motor rated frequency	Set the rated motor frequency
F05.04	Motor rated speed	Set motor rated speed
F05.05	Motor rated voltage	Set motor rated voltage
F05.06	Motor rated current	Set the rated motor current
F05.30	Speed feedback or encoder type	Set the encoder type to ABZ encoder
F05.31	ABZ encoder line number	Set the actual number of lines of the inverter
F05.20	Motor parameter auto-tuning selection	After the above data is set, the self-learning in rotation is selected.

Installation and Size

● **Installation Instructions and Schematic**

- 1: Disconnect the inverter from the power supply. After the keyboard is off, remove the inverter mask
- 2: Align the PG card socket with the EX-A/EX-B pin on the inverter, so that the socket is inserted vertically. The fixing buckle will automatically clamp the PG card without screwing.

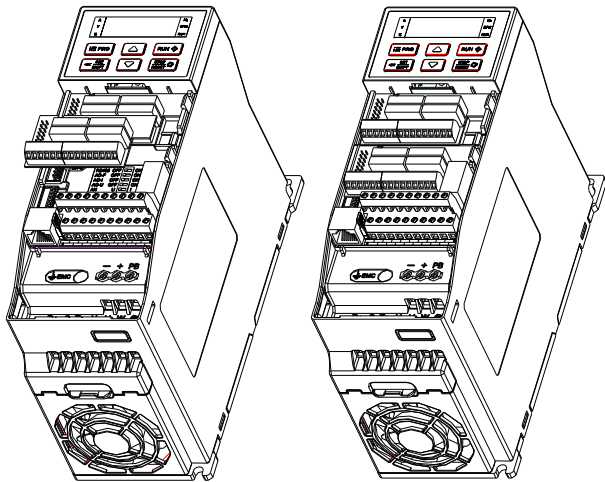

● **Board size chart**

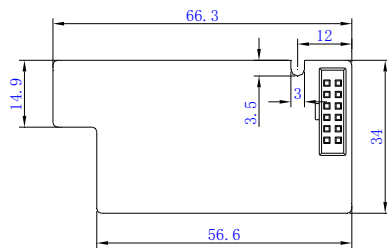

Revision history

Date	Version	Update content	Editor
Sept. 4, 2018		Initial issue	

Warranty Card**Profile**

User Name : _____

Address : _____

Contacts : _____ Phone : _____ Fax : _____

Model : _____ Machine Code : _____

Agent/Distributor Profile

Delivery Company : _____

Contacts : _____ Phone : _____ Delivery Date : _____

Warranty Clauses

The Company solemnly states that since the day users purchase from my company (hereinafter referred to as manufacturer), they can enjoy the following warranty services:

1. Since the date of purchase, users can enjoy the following warranty services of the product:
 - 1) Within 30 days after shipment, the company promises returning, replacement and maintenance of the product.
 - 2) Within 90 days after shipment, the company promises replacement and maintenance of the product.
 - 3) Within 18 months after shipment, the company promises only maintenance of the product.
 - 4) Products exported to countries except China shall not enjoy the warranties mentioned above.
2. Since the date of purchase, users can enjoy the service of the company when they pay for the service.
3. Exception Clauses: Product failures caused by the following reasons would not enjoy the free warranty services of the manufacturer:
 - 1) Failures caused by operations of users that is not operated in accordance with the requirements of the product manual;
 - 2) Failures caused when users repair or renovate the product without communicating with the manufacturer in advance;
 - 3) Failures caused by abnormal aging of the product resulted from poor using environment;
 - 4) Failures caused by earthquake, fire or other natural disasters or abnormal voltage;
 - 5) Failures caused by damage during transportation (mode of transportation is decided by users and the company only helps to handle cargo shipment procedures).
4. In the following conditions, the manufacturer have the right not to provide warranty services:
 - 1) When the marks, trademarks or nameplates of the products are destroyed or can not be identified;
 - 2) When users do not pay for the product according to signed contract;
 - 3) When users intentionally hiding the improper operations during installation, wiring and maintenance;
5. For products that enjoy all returning, replacement and maintenance services, first the product should be returned to the company and after responsibility confirmation, the product can be replaced or repaired.

Certificate of Approval

QC check : _____



The product has been checked and proved to be qualified for delivery in conformity with standard.