

Chapter 1 Safety Requirement and Cautions

To ensure safety of your health, equipment and property, please read this chapter carefully before using the frequency inverter and act in compliance with the instructions when installing, debugging, running and overhauling the frequency inverter.

1.1 Safety Definition

Danger: it will cause danger of serious injuries and even death while operating against the rules.

Caution: it will cause danger of light injuries or equipment destruction while operating against the rules.

Note: some information is useful while operating and use frequency inverter.

1.2 Safety Requirements and Cautions

● Before Installation

Danger

1. Only qualified personnel can operate the equipment. Before operating, be sure to carefully read the manual about safety, installation, operation and maintenance. The safe operation depends on the proper processes of choosing models, carrying, installation, operation and maintenance.

Danger

1. Don't use the damaged or incomplete frequency inverters; Otherwise, there is risk of injury.

● Installation

Danger

1. Please install the frequency inverter on metal or other nonflammable material, and keep it away from the combustible material. Otherwise there is danger of fire;
2. No unauthorized modification to the frequency inverter; Otherwise there is danger of damaged.
3. Normal frequency inverter, which is not explosion-proof, can not be installed where with explosive gas or dust; Otherwise there is danger of explosion.

Attention

1. When two frequency inverters are installed in the same control cabinet, please pay attention to the installing place to guarantee the effective heat dissipation.
2. When carrying the frequency inverter, please support its bottom.

● Wiring

Danger

1. Wire is connected only when the main circuit is cut off, otherwise there is a danger of shock.
2. Wire is connected by professional person only. Otherwise there is a danger of shock.
3. Earth must be reliable. Otherwise there is a danger of shock.
4. AC power supply should not be connected with output ports U, V, W, otherwise there is a danger of damage to frequency

inverter.

5. No drop of bolt, spacer, metal stick, conducting wire or other things into the inner of frequency inverter; Otherwise there is a danger of fire or damage to frequency inverter.

Attention

1. If the damage to frequency inverter or other equipment is caused by improper wiring and utilization or unauthorized alteration, the user should shoulder all responsibilities.
2. Please make sure all wirings meet EMC requirement and satisfy safety standard in the local area; Please refer to recommendations in this manual or national standards of wire diameter to avoid accidents.
3. Static electricity on human body would seriously damage internal MOS transistor, etc. No touch the printed circuit boards, IGBT or other internal devices without anti-static measure, otherwise it will cause the malfunction of frequency inverter.
4. Please don't connect phase shifter capacitance or LC/RC noise filter to the output circuit of frequency inverter; Otherwise it will damage the frequency inverter.
5. Please don't connect the magnetic switch or magnetic contactor to the output circuit of frequency inverter; When frequency inverter is in the operation with load, magnetic switch or magnetic contactor can make inverter over-current protection function act. It will damage frequency inverter seriously.
6. Please don't disassemble the panel cover, it only needs to disassemble the terminal cover when wiring.
7. It is forbidden to do any pressure test on frequency inverter, otherwise it will damage the frequency inverter.

●Before Electrification

Danger

1. Please make sure that voltage grade of power supply is consistent with frequency inverter's voltage and then check whether the wiring is correct and firm, and whether there is short circuit in peripheral equipment's circuit. Otherwise it will damage frequency inverter and other equipment.
2. Before the frequency inverter is connected to the input power supply, make sure that the cover has been well fixed. Otherwise it will cause electric shock.
3. For the frequency inverters whose storage time is over 1 year, when electrification, the voltage should be raised by booster from low to high. Otherwise it will damage the frequency inverter.

Attention

1. Check if all periphery fittings are wired properly according to the handbook; Otherwise it will cause accidents.

●After Electrification

Danger

1. After electrified, it is forbidden to open the cover, make wiring, and check up; Otherwise, it will cause the danger of electric shock.
2. After electrified, it is forbidden to contact internal wiring board and its parts. Otherwise it will cause the danger of electric shock.
3. Do not operate or touch frequency inverter with wet hand. Otherwise there is danger of damage to frequency inverter and electric shock.

Attention

1. Please set the parameter of frequency inverter cautiously; Otherwise it will damage equipment.

●Operation

Danger

1. Before running, please check and confirm the application range of the machine and equipment once more; Otherwise it will cause accidents.
2. Please don't touch the cooling fan and braking resistance to check the temperature; Otherwise there is a danger of getting burn.
3. Unprofessional workers are banned to check the signals in the running stage; Otherwise it will cause injuries and damage the equipment.

Attention

1. Please don't turn off the equipment by switching off power; Please cut off the power supply after the electric machine stops running; Otherwise it will damage the frequency inverter.
2. Please avoid anything dropping into the equipment when the frequency inverter is running; Otherwise it will cause electric shock.

●Maintenance

Danger

1. Please don't maintain and repair the equipment with electric; Otherwise it will cause electric shock.
2. Before maintaining and repairing the frequency inverter, please make sure the indicator lights of power supply have completely turned off; Otherwise it may cause electric shock and damage the frequency inverter.
3. Persons who have not passed specialized train are not allowed to conduct the frequency inverter maintenance; Otherwise it may cause electric shock and damage the frequency inverter.

1.3 Cautions in Using

1. In application of this series frequency inverter, you have to confirm all machine insulation to prevent damage to the equipment. Moreover, when the motor working in tough environment, please periodic inspect the electrical insulation to ensure the safety of the system work.
2. If the motor adapter is not consistent with frequency inverter's rating current (The rating current of the motor is far smaller than that of frequency inverter), please adjust the protective value to ensure safe running.
3. In occasions such as load raises, usually there is negative torque and frequency inverter breaks off for over-current or over-voltage. In this case, you should consider choosing the matching brake unit.
4. Frequency inverter, in a certain output frequency range, can meet the mechanical resonance of the load equipment. To avoid it, you can set up jumping frequency.
5. As output voltage of the inverter is pulse-wave type, if there is capacity which can improve power factor or pressure-sensitive resistance which used for thunder-proof in the voltage output side, the frequency inverter will break off or its parts will be damaged, so it is necessary to dismantle them. Moreover, it is proposed not install switch parts like air switch and contactor (if it is necessary to install switch on output side, please make sure the output electricity of frequency inverter is zero when the switch is working)
6. At over 1,000 meters altitude, the inverter's heat dissipation function worsened due to the thin air, it is necessary to use

less.

7. The inverter output voltage is pulse wave type. If using digital multi-meter measurement, deviation of the reading will be great. And the deviation is different by using different type of digital multi-meter. Under normal circumstances, while RMS 380V, digital multi-meter reading is around 450V.
8. Solar panel can be connected in the series or parallel. For rated voltage 380V controller, we suggest working voltage between 480V and 560V while MPPT. What means the solar panel open circuit voltage should be between 600V and 700V.

1.4 Technical Specification

Solar pump inverter power(KW)	Pump		Max solar power input (KW)	Max DC input voltage V	Recommend Voc voltage (V)	Rated output current (A)	Output frequency (Hz)
	Rated power (KW)	Rated voltage (V)					
SI23-D1 series, DC60-400VDC input, 3 phase 110-230VAC output							
0.75	0.75	110	1.5	400	175~380	7A	0-320
1.5	1.5	110	2.25	400	175~380	10A	0-320
SI23-D3 series,DC150V-450V input, 3 phase 220-240VAC output							
0.75	0.75	220	3.0	450	360~430	4A	0-320
1.5	1.5	220	3.0	450	360~430	7A	0-320
2.2	2.2	220	3.3	450	360~430	10A	0-320
4	4	220	6	450	360~430	16A	0-320
SI23-D5 series,DC250V to 780VDC input, 3 phase 380-460VAC output							
0.75	0.75	380	4	800	620~750	3.0	0-320
1.5	1.5	380	4	800	620~750	4.0	0-320
2.2	2.2	380	4	800	620~750	6.0	0-320
4	4	380	6	800	620~750	10	0-320
5.5	5.5	380	8.5	800	620~750	13	0-320
7.5	7.5	380	11	800	620~750	17	0-320
11	11	380	16	800	620~750	25	0-320
15	15	380	22.5	800	620~750	32	0-320
18.5	18.5	380	27.7	800	620~750	38	0-320
22	22	380	33	800	620~750	45	0-320
30	30	380	45	800	620~750	60	0-320
SI23-T3 series,DC350V to 780VDC input,3phase 380-440VAC output							
37	37	380	57	800	620~750	75	0-320
45	45	380	69	800	620~750	90	0-320
55	55	380	85	800	620~750	110	0-320
75	75	380	115	800	620~750	150	0-320
90	90	380	135	800	620~750	180	0-320
110	110	380	165	800	620~750	210	0-320
132	132	380	198	800	620~750	250	0-320
160	160	380	235	800	620~750	310	0-320
185	185	380	240	800	620~750	340	0-320
200	200	380	250	800	620~750	380	0-320

Note: for D5/T3 inverter software overvoltage value: 780VDC

1.5 Cautions in Disposal

When you dispose frequency inverter, please pay attention to:

1. Electrolytic capacitor: the electrolytic capacitor of main circuit or the printing plate may explode when they are burned.
2. Plastic: plastic incineration may generate toxic gases.
3. Dispose method: please dispose as industrial waste.

Chapter 2 Installation and Wiring

2.1 Dimension of Inverter

Overall Dimension of Inverter (Plastic)

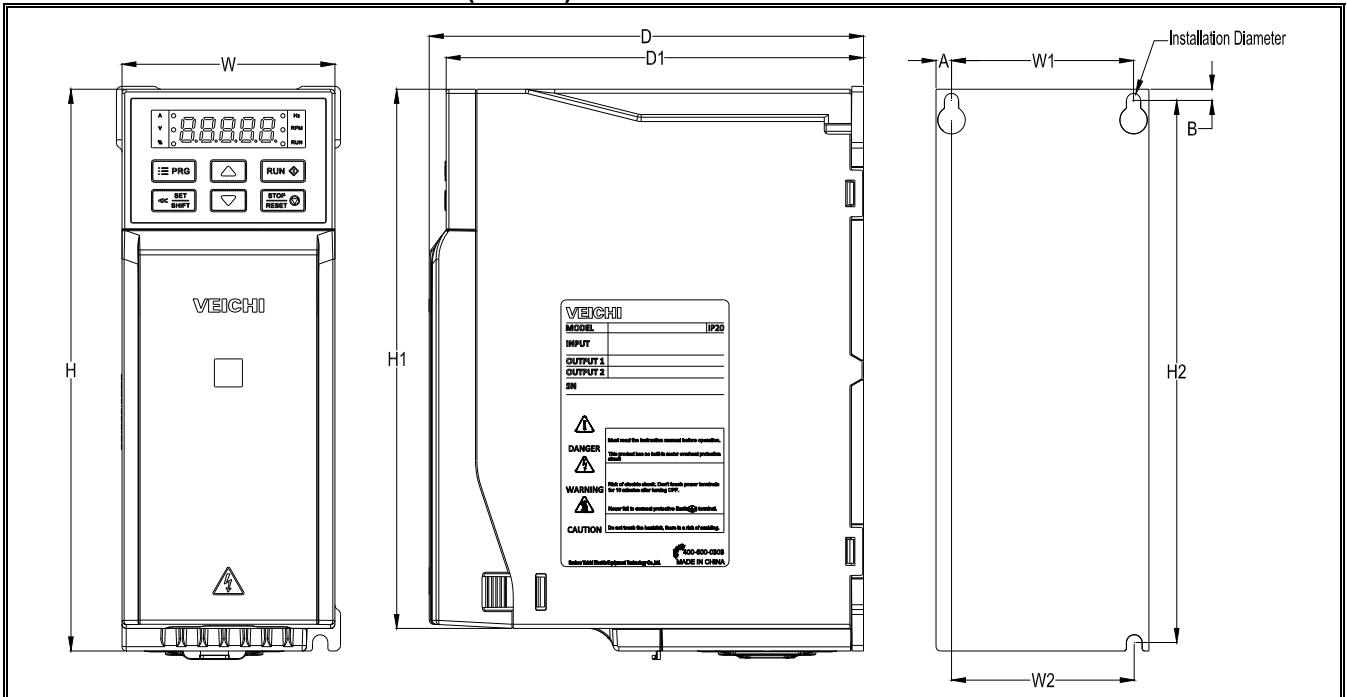

MODEL	Overall Dimension(mm)					Installation Dimension(mm)					Aperture
	W	H	H1	D	D1	W1	W2	H2	A	B	
SI23-D3-R75G	76	200	192	155	149	65	65	193	5.5	4	φ3-M4
SI23-D3-1R5G											
SI23-D3-2R2G	100	242	231	155	149	84	86.5	231.5	8	5.5	φ3-M4
SI23-D3-004G											
SI23-D5-R75G	76	200	192	155	149	65	65	193	5.5	4	φ3-M4
SI23-D5-1R5G											
SI23-D5-2R2G											
SI23-D5-004G	100	242	231	155	149	84	86.5	231.5	8	5.5	φ3-M4
SI23-D5-5R5G											
SI23-D5-7R5G	116	320	307.5	175	169	98	100	307.5	9	6	φ3-M5
SI23-D5-011G											

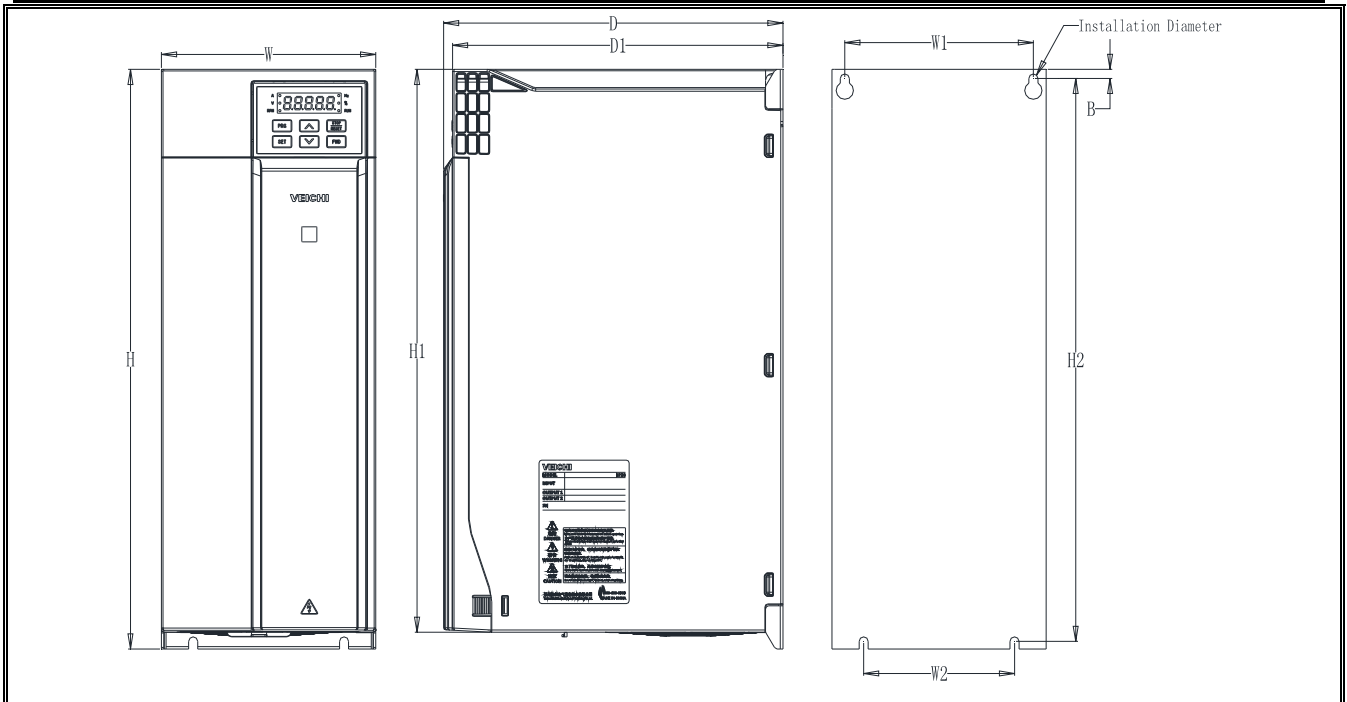

MODEL	Overall Dimension(mm)					Installation Dimension(mm)				Aperture
	W	H	H1	D	D1	W1	W2	H2	B	
SI23-D5-015G	142	383	372	225	219	125	100	372	6	φ4-M5
SI23-D5-018G										
SI23-D5-022G										
SI23-D5-030G	172	430	/	255	219	150	150	416.5	7.5	φ4-M5
SI23-T3-037G										

Overall Dimension of Inverter (Steel)

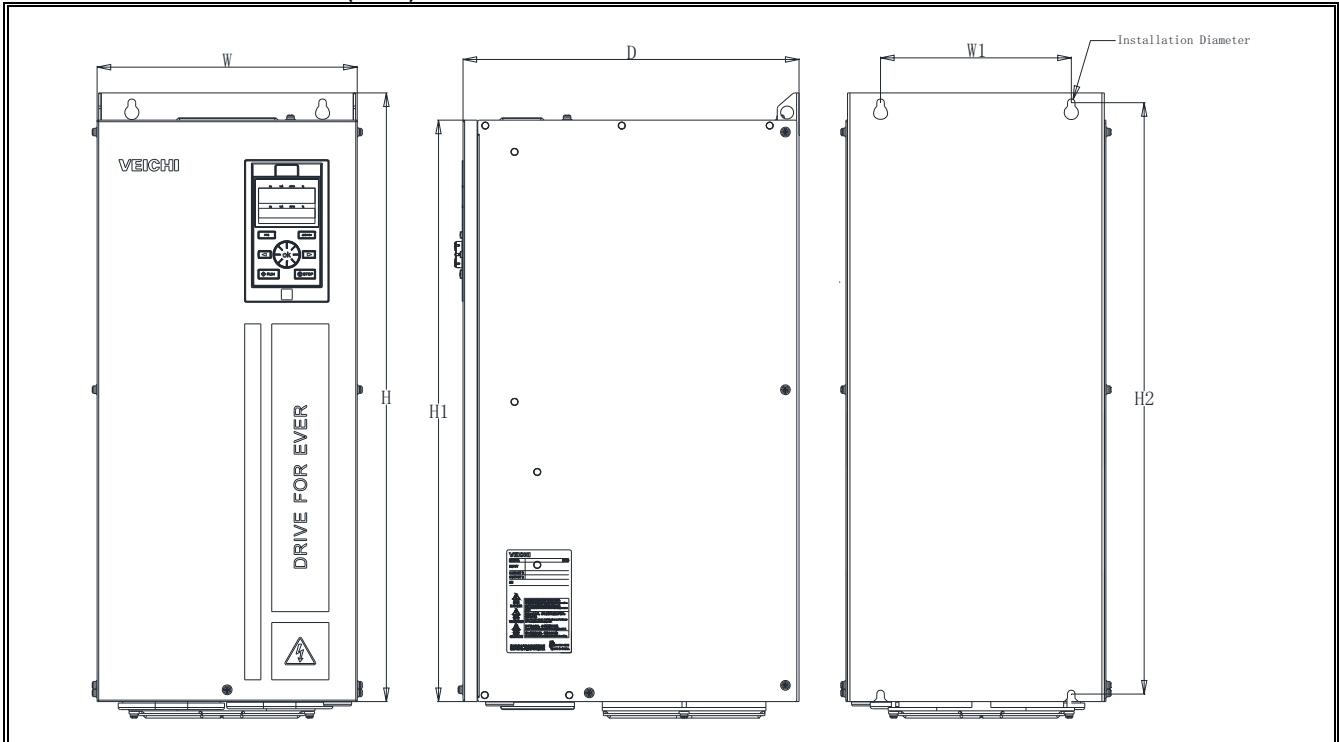

MODEL	Overall Dimension(mm)				Installation		Aperture
	W	H	H1	D	W1	H2	
SI23-T3-045G	240	560	535	310	176	544	φ4-M6
SI23-T3-055G							
SI23-T3-075G							
SI23-T3-090G	270	638	580	350	195	615	φ4-M8
SI23-T3-110G							
SI23-T3-132G	350	738	680	405	220	715	φ4-M8
SI23-T3-160G							
SI23-T3-185G	360	940	850	480	200	910	φ4-M16
SI23-T3-200G							
SI23-T3-220G							
SI23-T3-250G	370	1140	1050	545	200	1110	φ4-M16
SI23-T3-280G							

2.2 Solar Pump Controller Wiring

● Standard Connection Diagram

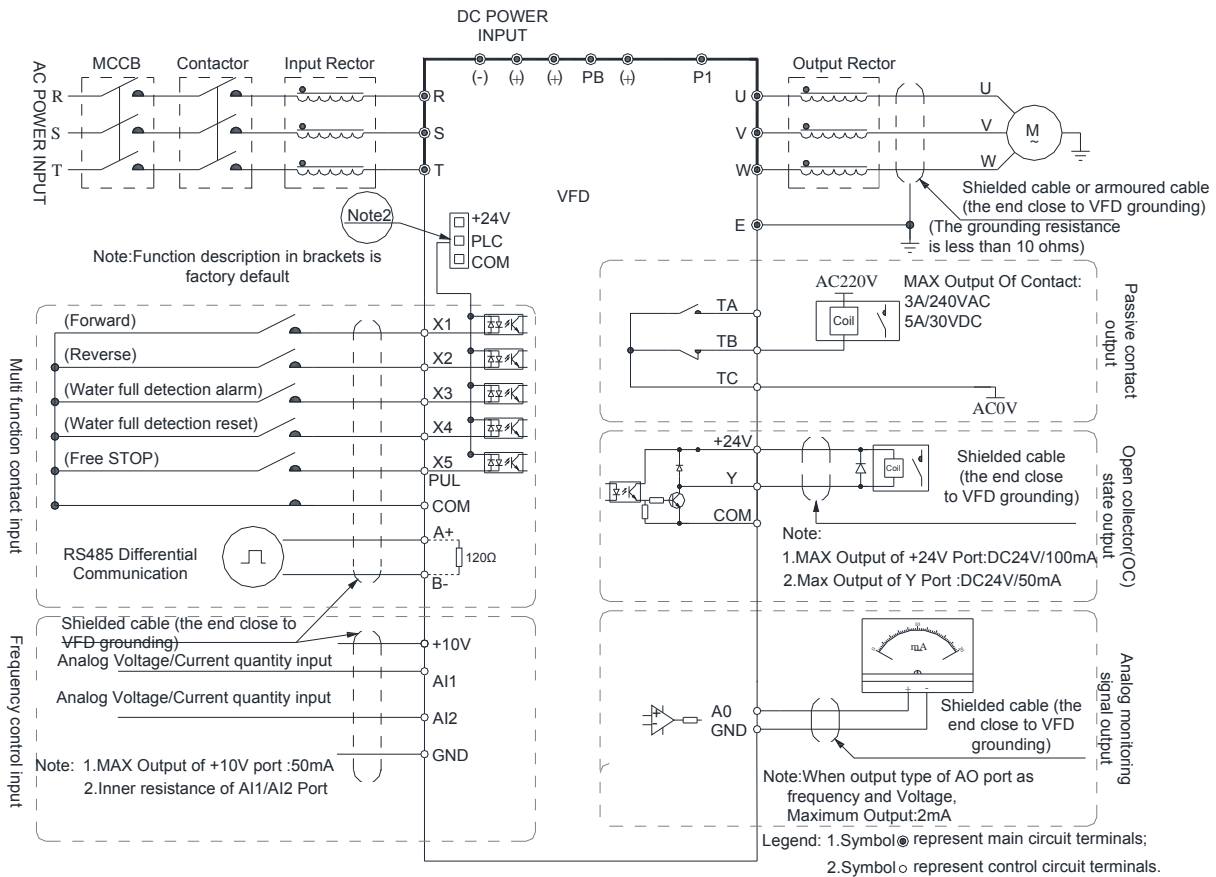

Note: When connect solar panel, both AC input (R, T) and DC input (+, -) is okay, AC input is prefer.

● Auxiliary Terminal Output Capacity

Terminal	Function Definition	Max Output
+10V	10V auxiliary power supply output, constitutes loop with GND.	50mA
A0	Analog monitor output, constitutes loop with GND.	Max output 2mA as frequency, voltage signal
+24V	24V auxiliary power supply output, constitutes loop with COM.	100mA
Y	Collector open circuit output; can set the action-object by program.	DC24V/50mA
TA/TB/TC	Passive connector output; can set the action-object by program.	3A/240VAC

● Function Specification of Switch Terminals

Switch Terminal	Selecting Position	Function Specification
RS485	OFF <input type="checkbox"/> ON <input type="checkbox"/>	RS485 Terminal Resistor
AO-F	OFF <input type="checkbox"/> ON <input type="checkbox"/>	AO-F Output- frequency
AO-I	OFF <input type="checkbox"/> ON <input type="checkbox"/>	AO-I Output- Current
AO-U	OFF <input type="checkbox"/> ON <input type="checkbox"/>	AO-U Output- Voltage
AI1	U <input type="checkbox"/> I <input type="checkbox"/>	AI1 Input- Current/Voltage
AI2	U <input type="checkbox"/> I <input type="checkbox"/>	AI2 Input- Current/Voltage





Function Specification:
 RS485 Communication :connect with 120Ω terminal resistor
 0~100kHz frequency output
 0~20mA current output or 4~20mA current output
 0~10V voltage output
 AI1: Input 0~20mA or 0~10V
 AI2: Input 0~20mA or 0~10V

Chapter 3 Keyboard layout and functions specification

•Keyboard Appearance







•Key function

Key	Name	Function
	Menu key	Enter menu while standby or running. Presses this key to return while modify parameter. While standby or running, press for 1 sec to enter condition monitoring
	Confirm/Shift key	Press to modify parameter while in menu interface. Press again to confirm after modifying; Press this key for 1 Sec to shift digit, and long press to cycle. Each digit flashes three time to shift to next digit.
	Up/down key	Select parameter group in menu interface. Modify parameter in modify state. Modify given frequency, ID given while at standby or monitoring state (While given frequency, PID are set by keyboard and [F4.09] needs to be set.
	Run key	While run/stop is controlled by keyboard, press this key, inverter forward runs, and the indicator is always on. While reverse, the indicator sparks.
	Stop/reset key	Machine stops if press it while run/stop is controlled by keyboard. Its efficiency range is defined by [F4.08] . Inverter resets if press it in fault state (no reset if fault is not





Chapter 4 Fault Diagnosis and Solution

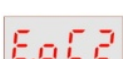

This chapter describes the inverter fault, alerts, and operation of the failure on the inverter, the display information on inverter and countermeasures.

Fault Information and Description in Detail

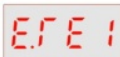
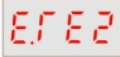
Keypad display	Fault code	Fault type	Possibility reason	Troubleshooting
	E.LU2	Under voltage at runs	<ul style="list-style-type: none"> ● Power voltage too low ● DC main contactor don't close 	<ul style="list-style-type: none"> ● Check input power to solve ● Ask support
	E.oU1	Over voltage at acceleration	<ul style="list-style-type: none"> ● Power voltage fluctuation over limit ● Too start rotating motor 	<ul style="list-style-type: none"> ● Check power grid ● Restart until motor is stop completely, or set [F1.00] set for 1 or 2
	E.oU2	Over voltage during deceleration	<ul style="list-style-type: none"> ● Deceleration time too small ● The driving load too heavy ● Power voltage fluctuation over limit 	<ul style="list-style-type: none"> ● Prolong deceleration time ● Reduce the load, or select bigger capacitor drive, or connect braking unit ● Check input power
	E.oU3	Overvoltage at constant speed	<ul style="list-style-type: none"> ● The input voltage is too high. ● An external force drives the motor during deceleration 	<ul style="list-style-type: none"> ● Adjust the voltage to normal range. ● Cancel the external force or install the braking resistor.
	E.oU4	Over voltage at stop	<ul style="list-style-type: none"> ● Voltage fluctuate above limit 	<ul style="list-style-type: none"> ● Check the input voltage
	E.oC1	Over current during acceleration	<ul style="list-style-type: none"> ● Acceleration time is too short ● To start rotating motor ● V/F setting not correct or torque boost setting too big ● Solar drive capacitor is too small 	<ul style="list-style-type: none"> ● Prolong acceleration time ● Restart motor when it on still, or set F1.00 for 1 or 2. ● Reset V/f curve or torque boost setting
	E.oC2	Over current during deceleration	<ul style="list-style-type: none"> ● The output circuit is grounded or short circuited. ● Motor auto-tuning is not performed. ● The acceleration time is too short. ● Manual torque boost or V/F curve is not appropriate. ● The voltage is too low. 	<ul style="list-style-type: none"> ● Eliminate external faults. ● Perform the motor auto tuning. ● Increase the acceleration time. ● Adjust the manual torque boost or V/F curve. ● Adjust the voltage to normal range. ● Select rotational speed tracking restart or start the motor after it

			<ul style="list-style-type: none"> ●The startup operation is performed on the rotating motor. ●A sudden load is added during acceleration. ●The AC drive model is of too small power class. 	<p>stops.</p> <ul style="list-style-type: none"> ● Remove the added load. ● Select an AC drive of higher power class.
E.oL3	E.oC3	Over current at constant speed	<ul style="list-style-type: none"> ●The output circuit is grounded or short circuited. ●Motor auto-tuning is not performed. ●The voltage is too low. ● A sudden load is added during operation. ●The AC drive model is of too small power class 	<ul style="list-style-type: none"> ● Eliminate external faults. ●Perform the motor auto tuning. ●Adjust the voltage to normal range. ● Remove the added load. ● Select an AC drive of higher power class.
E.oL1	E.oL1	Motor overload	<ul style="list-style-type: none"> ● Boost torque is too big under VF control ●ACC. and DEC. time is too short ●Motor parameters setting is improperly ●Restart motor which in counter rotate ●The grid voltage is too lower ●Load is too big or motor block load ●AC drive selected is too load 	<ul style="list-style-type: none"> ●Reduce boost torque ●Increase the ACC./DEC. time ● Reset motor parameters ●Reduce current limit and adopt speed tracking ● Check grid voltage ● Check load condition ●Change bigger power AC drive
E.oL2	E.oL2	AC drive overload	<ul style="list-style-type: none"> ●Boost torque is too big under VF control ●ACC. and DEC. time is too short ●Motor parameters setting is improperly ●Restart motor which in counter rotate ●The grid voltage is too lower ●Load is too big or motor block load ●AC drive selected is too load 	<ul style="list-style-type: none"> ●Reduce boost torque ● increase the ACC./DEC. time ●reset motor parameters ●Reduce current limit and adopt speed tracking ● Too check grid voltage ●Too check load ●change bigger power AC drive

	E. SC	System abnormal	<ul style="list-style-type: none"> ●Deceleration is too short ●Short circuit of solar drive output or phase output short circuit to ground ● Module damage ● EMC interface 	<ul style="list-style-type: none"> ● Prolong acceleration time ● To check peripheral equipment ● Ask to support ● Check the wiring layout, cable ground
	E.oH1	Inverter over-heat	<ul style="list-style-type: none"> ●Temperature is too high. ●Air channel is blocked. ●Fan connection parts is loose. ●Fan is damaged. ●Temperature detection circuit fault. 	<ul style="list-style-type: none"> ● Make the environment meet the requirement. ● Clear the air channel. ● Check and reconnect the wire ● Change the same new fan. ● Seek support from factory.
	E.oH2	Rectifier over-heat	<ul style="list-style-type: none"> ●Temperature is too high. ● Air channel is blocked. ● Fan connection parts is loose. ● Fan is damaged. ● Temperature detection circuit fault 	<ul style="list-style-type: none"> ●Make the environment meeting the requirement. ● Clear the air channel. ● Check and reconnect the wire. ● Change the same new fan. ● Seek support from factory.
	E.TE1	Motor static detection fault	<ul style="list-style-type: none"> ● Detection overtime ●Start static detection while motor is running. ● Capacitance difference is too big between motor and inverter. ●Motor parameter setting mistake. 	<ul style="list-style-type: none"> ● Check motor connection wire. ● Detect after motor stopping totally. ● Change inverter model. ● Reset parameter according to nameplate.
	E.TE2	Motor rotation detection fault	<ul style="list-style-type: none"> ●Detect while motor is running. ● Detect with load. ● Detection overtime ●Capacitance difference is too big between motor and inverter. ●Motor parameter setting mistake. 	<ul style="list-style-type: none"> ● Detect after motor stop totally. ● Re-detect without load. ● Check motor connection wire. ● Change inverter model. ● Reset parameter according to nameplate.
	E.EEP	Memory fault	<ul style="list-style-type: none"> ●Electromagnetic disturb in memory period. ● EEPROM damage. 	<ul style="list-style-type: none"> ● Resume load and save. ● Seek support from factory.
	LIFE	Reserved		

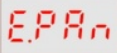
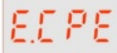
	E.ILF	Input phase loss	<ul style="list-style-type: none"> ●3-phase input power open phase. 	<ul style="list-style-type: none"> ●Check 3-phase power supply and the phase. ●Check 3-phase power supply wiring.
	E.oLF	Output phase loss	<ul style="list-style-type: none"> ●3-phase output power open phase 	<ul style="list-style-type: none"> ● Check 3-phase output voltage and current. ● Check wiring.
	E.Gnd	<ul style="list-style-type: none"> ● Output earth terminal short circuit. 	<ul style="list-style-type: none"> ●Check wiring and insulation. 	<ul style="list-style-type: none"> ●Output earth
	E.HAL	Current detection fault	<ul style="list-style-type: none"> ● Detect circuit fault. ● Phase imbalance 	<ul style="list-style-type: none"> ●Seek support from factory ● Check motor and wiring.
	E.PAn	Keyboard connect fault	<ul style="list-style-type: none"> ● Keyboard wire fault. ●Keyboard component damage. 	<ul style="list-style-type: none"> ● Check keyboard wire. ●Seek support from factory.
	Rs485c ommuni cation fault	<ul style="list-style-type: none"> ● Unsuitable baud rate setting. ●Communication wire breaks. ●Communication format does not match upper machine. 	<ul style="list-style-type: none"> ●Set suitable baud rate setting. ●Check communication wire. ●Make sure right communication format. 	<ul style="list-style-type: none"> ●RS485communication fault
	E.CPE	Parameter copy fault	<ul style="list-style-type: none"> ●Parameter copy communication is fault. ●Copy keyboard does not match the inverter. 	<ul style="list-style-type: none"> ● Check wire. ●Select the specified external keyboard model.

Chapter 5 Parameters List

This chapter just provides function parameter table. Specifications refer to AC300 technical manual or inquiry the company.

- “●” : Parameter can be changed in the running state.
- “○” : Parameter can't be changed in the running state.
- “×” : Parameter can be read only.
- “-” : Factory setting parameter, only factory can set.
- “※” : Parameter is related to the model.

Basic parameters

NO.	Function description	Range of settings and definition		Factor y	Feature	Address
F00.00	Motor control mode	Asynchronous motor control mode: 0: V/F control Synchronous motor control mode: 6: High-performance VC without PG		0	○	0x000
F00.01	Reserved					
F00.02	Run command channel	0: Keyboard control 1: Terminal control	2: RS485 communication control 3: Reserved	0	●	0x002
F00.03	Frequency given source channel A	0: Keyboard number given 1: Reserved 2: Voltage/Current analog AI1 given 3: Voltage/Current analog AI2 given 4: Reserved 5: Terminal pulse PUL given 6: RS485 communication given		0	●	0x003
F00.04	Frequency given source channel B	7: Terminal UP/DW control 8: PID control given 9: Program control (PLC) given 10: Optional card 11: Multi-steps speed given		1	●	0x004
F00.05	Frequency channel B reference source	0: Max. output frequency as reference source 1: Set frequency of channel A as reference source		0	●	0x005
F00.06	Frequency given source selection	0: Channel A 1: Channel B 2: Channel A+Channel B 3: Channel A-Channel B 4: Max. value of Channel A and Channel B 5: Min. value of Channel A and Channel B		0	●	0x006
F00.07	Running Command Binding	LED“0”digit: keyboard command instruction binding LED“00”digit: terminal command instruction binding LED“000”digit: communication command instruction binding		0000	●	0x007

		LED“0000”digit: optional card command instruction binding 0 : no binding 1 : keyboard number given frequency 2 : Reserved 3 : Voltage/Current analog AI1 given 4 : Voltage/Current analog AI2 given 5 : Reserved 6 : Terminal pulse PUL given 7 : RS485 communication given 8 : Terminal UP/DW control 9 : PID control given A : Program control (PLC) given B : Optional card C : Multi-steps speed given				
F00.08	Keyboard digital	0~upper limit	50.00 Hz	●	0x008	
F00.09	Max	upper limit~600.00Hz	50.00	○	0x009	
F00.10	Upper limit frequency source selection	0: Upper limit frequency digital given 1: Reserved 2: Voltage/Current analog AI1 give 3: Voltage/Current analog AI2 given 4: Reserved 5: Terminal pulse PUL given 6: RS485 communication given 7: Optional card	0	●	0x00A	
F00.11	Upper frequency	Lower limit frequency~max frequency	50.00 Hz	●	0x00B	
F00.12	Lower limit	0.00~upper limit frequency	0.00H	●	0x00C	
F00.13	Lower limit frequency running mode	0: Stop output, enter into pause running state 1: Run at lower limit frequency	1	○	0x00D	
F00.14	ACC time 1	0.01~650.00s	20.00	※	0x00E	
F00.15	DEC time 1	0.01~650.00s	20.00	※	0x00F	
F00.16	Rotary direction selection	LED“0”digit: running direction takes the opposite 0: Direction unchanged 1: Direction takes the opposite LED“00”digit: running direction prohibited 0:Forward and reverse commands are allowed 1: Only FWD command allowed 2: Only REV command allowed LED“000”digit: frequency control direction selection 0: Invalid 1: Valid LED“0000”digit: reserved	0000	○	0x010	
F00.17	G/P Model Setting	0:G Type 1:P Type	0	●	0x011	

F00.18	Reserved				
F00.19	Parameter initialization	0: No action 1: Restore factory default (not restoring motor parameters) 2: Restore factory default (restoring motor parameters) 3: Clear malfunction records	0	○	0x013

Operation Control Parameters Group

NO.	Function description	Range of settings and definition		Factory setting	Feature	Address
F01.00	Start-up running mode	0: Start by start-up frequency 1: DC Braking at first then start by start-up frequency 2: Speed tracking, and judge the direction then start		0	○	0x100
F01.01	Start	0.00~60.00s		0.00s	○	0x101
F01.02	Start-up	0.00~60.00Hz		0.50Hz	○	0x102
F01.03	Start-up	0.0~50.0s		0.0s	○	0x103
F01.04	Braking	0.0~150.0%		60.0%	○	0x104
F01.05	Braking time	0.0~60.0s		0.0s	○	0x105
F01.06	Speed	0.00~60.00s		0.50s	○	0x106
F01.07	Speed	0.00~60.00s		1.00s	○	0x107
F01.08	Reserved					
F01.09	Reserved					
F01.10	Stop mode	0:DEC stop	1:Free stop	0	●	0x10A
F01.11	DC braking initial	0.00~50.00Hz		1.00Hz	○	0x10B
F01.12	DC braking	0.0~150.0%		60.0%		0x10C
F01.13	Reserved					0x10D
F01.14	DC braking	0.0~60.0s		0.0s	○	0x10E
F01.15	Stop	0.00~50.00Hz		0.50Hz	●	0x10F
F01.16	ACC/DEC selection	LED "0" digit: time base selection 0: max frequency 1: fixed frequency 50Hz 2: set frequency LED "00" digit: S ACC/DEC selection 0: Beeline ACC/DEC 1: S Curve ACC/DEC LED "000" digit: reserved LED "0000" digit: reserved		0010	○	0x110
F01.17	ACC start	0.00~10.00		0.20s	○	0x111
F01.18	ACC end time	0.00~10.00		0.20s	○	0x112
F01.19	DEC start	0.00~10.00		0.20s	○	0x113
F01.20	DEC end time	0.00~10.00		0.20s	○	0x114

F01.21	ACC time 2	0.01~650.00s	10.00s	●	0x115
F01.22	DEC time 2	0.01~650.00s	10.00s	●	0x116
F01.23	ACC time 3	0.01~650.00s	10.00s	●	0x117
F01.24	DEC time 3	0.01~650.00s	10.00s	●	0x118
F01.25	ACC time 4	0.01~650.00s	10.00s	●	0x119
F01.26	DEC time 4	0.01~650.00s	10.00s	●	0x11A
F01.27	DEC time at	0.01~650.00s	1.00s	●	0x11B
F01.28	FWD&REV	0.0~120.0s	0.0s	○	0x11C
F01.29	Zero speed torque	0.00~10.00Hz	0.50Hz	●	0x11D
F01.30	Zero speed	0.0~150.0%	60.0%	●	0x11E
F01.31	Zero speed torque	0.0~6000.0s If set 6000.0S,always hold without time limit	0	●	0x11F
F01.3-F 01.34	Reserved				
F01.35	Power off	0:Invalid 1:Valid	0	○	0x123
F01.36	Power off	0.00~60.00s	0.50s	○	0x124
F01.37	Reserved				0x125
F01.38	JOG running	0.00-Max frequency	5.00Hz	●	0x126
F01.39	JOG ACC	0.01~650.00s	10.00s	●	0x127
F01.40	JOG DEC	0.01~650.00s	10.00s	●	0x128
F01.41	Jump	0.00~Max frequency	0.00Hz	●	0x129
F01.42	Jump	0.00~Max frequency	0.00Hz	●	0x12A
F01.43	Jump	0.00~Max frequency	0.00Hz	●	0x12B
F01.44	Jump	0.00~Max frequency	0.00Hz	●	0x12C

Switching value terminal parameters

NO.	Function description	Range of setting and definition	Factory setting	Feature	Address
F02.00	Input terminal 1(X1)	0: No function 1:Forward 2:Reverse 80: Water fulfilled detect alarm 81:Water fulfilled detect reset	1	○	0x200
F02.01	Input terminal 2(X2)		2	○	0x201
F02.02	Input terminal 3(X3)		80	○	0x202
F02.03	Input terminal 4(X4)		81	○	0x203
F02.04	Input terminal 5(X5)	Refer to function table 4.2	6	○	0x204
F02.05	Input terminal 6(X6 expand)	Refer to function table 4.2	0	○	0x205
F02.06	Input terminal 7(X7 expand)	Refer to function table 4.2	0	○	0x206
F02.07	Input terminal 8(X8 expand)	Refer to function table 4.2	0	○	0x207
F02.08	Input terminal 9(X9 expand)	Refer to function table 4.2	0	○	0x208
F02.09	Input terminal 10(X10 expand)	Refer to function table 4.2	0	○	0x209
F02.10	X1~X4 terminal trait selection	0: On valid 1: Off valid LED "0" digit: X1 LED "00" digit: X2 LED "000" digit: X3 LED "0000" digit: X4	0000	●	0x20A

F02.11	X5~X8 terminal trait selection	0: On valid 1: Off valid LED "0" digit: X5 LED "00" digit: X6 LED "000" digit: X7 LED "0000" digit: X8	0000	●	0x20B
F02.12	X9~X10 terminal trait selection	0: On valid 1: Off valid LED "0" digit: X9 LED "00" digit: X10 LED "000" digit: Reserved LED "0000" digit: Reserved	0000	●	0x20C
F02.13	X1 valid detection delay	0.000~6.000s	0.010	●	0x20D
F02.14	X1 invalid detection delay	0.000~6.000s	0.010	●	0x20E
F02.15	X2 valid detection delay	0.000~6.000s	0.010	●	0x20F
F02.16	X2 invalid detection delay	0.000~6.000s	0.010	●	0x210
F02.17	X3 valid detection delay	0.000~6.000s	0.010	●	0x211
F02.18	X3 invalid detection delay	0.000~6.000s	0.010	●	0x212
F02.19	X4 valid detection delay	0.000~6.000s	0.010	●	0x213
F02.20	X4 invalid detection delay	0.000~6.000s	0.010	●	0x214
F02.21	X5 valid detection delay	0.000~6.000s	0.010	●	0x215
F02.22	X5 invalid detection delay	0.000~6.000s	0.010	●	0x216
F02.23	Terminal control running mode	0: 2-line 1 1: 2-line 2 2: 3-line 1 3: 3-line 2	0	○	0x217
F02.24	Terminal operate protection	0: OFF 1:ON LED "0" digit: Terminal operate protection when abnormal exit LED "00" digit: Jog terminal operate protection when abnormal exit LED "000" digit: Operate protection when command channel switch to terminal	0111	○	0x218
F02.25	Counter input	0: Common X terminal 1: High speed input terminal PUL 2: PG card counting	0	●	0x219
F02.26	Count input frequency division	0~6000	0	●	0x21A
F02.27	PUL signal source	0: X5(max~5 KHz) 1: Extend interface X10	0	○	0x21B
F02.28	PUL input min frequency	0.00~50.00 KHz	0.00kHz	●	0x21C
F02.29	PUL min frequency corresponding setting	0.00~100.00%	0.00%	●	0x21D
F02.30	PUL input max frequency	0.00~50.00 KHz	50.00kHz	●	0x21E
F02.31	PUL max frequency corresponding setting	0.00~100.00%	100.00%	●	0x21F

F02.32	PUL filter time	0.000~9.000s	0.100s	●	0x220
F02.33	PUL cut-off frequency	0.000~1.000 KHz	0.010kHz	●	0x221
F02.34	UP/DW terminal control mode	0: Off electricity storage 1: Off electricity does not storage 2: Valid in running, clear zero at stop	0	○	0x222
F02.35	ACC/DEC speed of UP/DW terminal frequency control	0.01~50.00Hz/s	0.50Hz/s	●	0x223
F02.36	Reserved				0x224
F02.37	Timer time unit	0:Second 1:Minute 2:Hour	0	●	0x225
F02.38	Timer setting value	0~65000	0	●	0x226
F02.39	Counter max value	0~65000	1000	●	0x227
F02.40	Counter setting value	0~65000	500	●	0x228
F02.41	Reserved				0x229
F02.42	Output terminal polarity selection	0: Positive 1: Negative LED "0" digit: Terminal Y LED "00" digit: Relay output 1 LED "000" digit: Extended Y1 terminal LED "0000" digit: Extended Relay output 2	0000	●	0x22A
F02.43	Output terminal Y1	Refer to function table 4.2	1	●	0x22B
F02.44	Relay output	Refer to function table 4.2	4	●	0x22C
F02.45	Extend terminal Y1	Refer to function table 4.2			0x22D
F02.46	Extend relay output 2	Refer to function table 4.2			0x22E
F02.47	Y output delay time	0.000~6.000s	0.010s	●	0x22F
F02.48	Extend Y output delay output	0.000~6.000s	0.010s	●	0x230
F02.49	Relay 1 output delay time	0.000~6.000s	0.010s	●	0x231
F02.50	Extend relay 2 output delay	0.000~6.000s	0.010s	●	0x232
F02.51	Output frequency level	0.00~Max. frequency	30.00Hz	●	0x233
F02.52	FDT1 lag	0.00~Max. frequency	1.00Hz	●	0x234
F02.53	Output frequency level	0.00~Max. frequency	50.00Hz	●	0x235
F02.54	FDT2 lag	0.00~Max. frequency	1.00Hz	●	0x236
F02.55	Given frequency arriving checkout range	0.00~50.00Hz	2.00Hz	●	0x237
F02.60	Virtual vX1 terminal function selection	Refer to function table 4.2	0	●	0x238
F02.61	Virtual vX2 terminal function selection	Refer to function table 4.2	0	●	0x239
F02.62	Virtual vX3 terminal function selection	Refer to function table 4.2	0	●	0x23A
F02.63	Virtual vX4 terminal function selection	Refer to function table 4.2	0	●	0x23B

F02.64	vX terminal valid state source	0: internal connection with virtual vYn 1: Connect with physical terminal Xn 2: function code setting valid or not LED “0” digit: virtual vX1 LED “00” digit: virtual vX2 LED “000” digit: virtual vX3 LED “0000” digit: virtual vX4	0	●	0x23C
F02.65	Virtual vX terminal function code setting valid state	0: invalid 1: valid LED “0” digit: virtual vX1 LED “00” digit: virtual vX2 LED “000” digit: virtual vX3 LED “0000” digit: virtual vX4	0	●	0x23D
F02.66	Virtual vY1 terminal function selection	Refer to function table 4.2	0	●	0x23E
F02.67	Virtual vY2 terminal function selection	Refer to function table 4.2	0	●	0x23F
F02.68	Virtual vY3 terminal function selection	Refer to function table 4.2	0	●	0x240
F02.69	Virtual vY4 terminal function selection	Refer to function table 4.2	0	●	0x241
F02.70	vY1 output delay	0.000~6.000s	0.010	●	0x242
F02.71	vY2 output delay	0.000~6.000s	0.010	●	0x243
F02.72	vY3 output delay	0.000~6.000s	0.010	●	0x244
F02.73	Virtual vY2 output selection	0.000~6.000s	0.010	●	0x245

Analog Terminal Parameters

NO.	Function description	Range of settings and definition	Factory setting	Feature	Address
F03.00	AI1 Lower limit	0.00~10.00V	0.00V	●	0x300
F03.01	AI1 Lower limit corresponding setting	-100.00~100.00%	0.00%	●	0x301
F03.02	AI1 upper limit	0.00~10.00V	10.00V	●	0x302
F03.03	AI1 upper limit corresponding setting	-100.00~100.00%	100.00%	●	0x303
F03.04	AI1 filter time	0.000~6.000s	0.010s	●	0x304
F03.05	AI1 zero point loop	0.00~10.00V	0.00V	●	0x305
F03.06	AI2 Lower limit	0.00~10.00V	0.00V	●	0x306
F03.07	AI2 Lower limit corresponding setting	0.00~100.00%	0.00%	●	0x307
F03.08	AI2 upper limit	0.00~10.00V	10.00V	●	0x308
F03.09	AI2 upper limit corresponding setting	0.00~100.00%	100.00%	●	0x309

F03.10	AI2 filter time	0.000~6.000s	0.010s	●	0x30A
F03.11	AI2 zero point loop	0.00~10.00V	0.00V	●	0x30B
F03.12	AI1 function selection	See X terminal function	0	○	0x30C
F03.13	AI1 high level setting	0.00~100.00%	70.00%	●	0x30D
F03.14	AI1 low level setting	0.00~100.00%	30.00%	●	0x30E
F03.15	AI2 function selection	See X terminal function	0	○	0x30F
F03.16	AI2 high level setting	0.00~100.00%	70.00%	●	0x310
F03.17	AI2 low level setting	0.00~100.00%	30.00%	●	0x311
F03.18	Valid state setting when analog used as terminal	0: low level 1: high level LED "0" digit: AI1 LED "00" digit: AI2 LED "000" digit: reserved LED "0000" digit: reserved	0000	●	0x312
F03.19	Analog input curve selection	LED "0" digit: AI1 0: Beeline (default) 1: curve 1 2: curve 2 LED "00" digit: AI2 (Select voltage or current input by wire jumper) LED "000" digit: reserved LED "0000" digit: reserved	0000	●	0x313
F03.20	Reserved				0x314
F03.21	Curve 1 lower limit	0.00~10.00V	0.00V	●	0x315
F03.22	Curve 1 lower limit corresponding setting	0.00~100.00%	0.0%	●	0x316
F03.23	Curve 1 inflection point 1 input voltage	0.00~10.00V	3.00V	●	0x317
F03.24	Curve 1 inflection point 1 corresponding	0.00~100.00%	30.00%	●	0x318
F03.25	Curve 1 inflection point 2 input voltage	0.00~10.00V	6.00V	●	0x319
F03.26	Curve 1 inflection point 2 corresponding	0.00~100.00%	60.00%	●	0x31A
F03.27	Curve 1 upper limit	0.00~10.00V	10.0V	●	0x31B
F03.28	Curve 1 upper limit corresponding setting	0.00~100.00%	100.00%	●	0x31C
F03.29	Curve 2 lower limit	0.00~10.00V	0.00V	●	0x31D
F03.30	Curve 2 lower limit corresponding setting	0.00~100.00%	0.00%	●	0x31E
F03.31	Curve 2 inflection point 1 input voltage	0.00~10.00V	3.00V	●	0x31F
F03.32	Curve 2 inflection point 1 corresponding	0.00~100.00%	30.00%	●	0x320
F03.33	Curve 2 inflection point 2 input voltage	0.00~10.00V	6.00V	●	0x321

F03.34	Curve 2 inflection point 2 corresponding	0.00~100.00%	60.00%	●	0x322
F03.35	Curve 2 upper limit	0.00~10.00V	10.00V	●	0x323
F03.36	Curve 2 upper limit corresponding setting	0.00~100.00%	100.00 %	●	0x324
F03.37	A0 output signal selection	LED "0" digit: AO1 0: 0~10V 1: 4.00~20.00mA 2: 0.00~20.00mA 3: FM frequency pulse output LED "00" digit: A02 extended card 0: 0~10V 1: 4.00~20.00mA 2: 0.00~20.00mA LED "000" digit: reserved LED 0000 digit: reserved	0000	●	0x325
F03.38	A01 output selection	0: Given frequency 1: Output frequency 2: Output current 3: Input voltage 4: Output voltage 5: Machine speed 6: Given torque 7: Output torque	0	●	0x326
F03.39	A02 extended output selection	8: PID given value 9: PID feedback value 10: Output power 11: Bus voltage 12: AI1 13: AI2 14: Reserved 15: PUL 16,17: IGBT temperature 1,2 18: RS485 given	1	●	0x327
F03.40	A01 output gain	25.0~200.0%	100.0%	●	0x328
F03.41	A01 analog output signal bias	-10.0%~10.0%	0.0%	●	0x329
F03.42	A01 output filter	0.000~6.000s	0.010s	●	0x32A
F03.43	A01 FM frequency output lower limit	0.00~100.00kHz	0.20kHz	●	0x32B
F03.44	A02FM frequency output upper limit	0.00~100.00kHz	50.00kHz	●	0x32C
F03.45	A02 extend output	25.0~200.0%	100.0%	●	0x32D
F03.46	A02 extend analog output signal bias	-10.0%~10.0%	0.0%	●	0x32E
F03.47	A02 extend output	0.000~6.000s	0.010s	●	0x32F
F03.48- F03.49	Reserved				

System parameters

NO.	Function description	Range of settings and definition	Factory setting	Feature	Address
F04.00	Parameter and key lock selections	0: Not locked 1: Function parameter locked 2: Function parameter and key locked (except for RUN/STOP/JOG) 3: All function parameter and key locked	0	●	0x400
F04.01	User password	0~65535	0	●	0x401
F04.02- F04.04	Reserved				
F04.05	Parameter copy	0: No function 1: Send inverter parameters to keyboard and save 2: Send keyboard parameters to inverter Remaining value: no operation	0	○	0x405
F04.06	Keyboard special function selection	LED "0" digit:(Running command, stop/reset command) 0: Built-in valid, external on valid for stop/reset command 1: External valid, built-in on valid for stop/reset command 2: All valid. Stop/reset command has the highest priority; invalid when FWD/REV valid at the same time LED "00" digit: reserved LED "000" digit: LCD keyboard language selection 0: Chinese 1: English	0000	○	0x406
F04.07	Reserved				0x407
F04.08	STOP key setting	0: Non-keyboard control mode is invalid 1: Non-keyboard control mode stops according to stop mode 2: Non-keyboard control mode stop according to free stop mode	1	○	0x408

F04.09	UP/DOWN key selection	<p>LED "0" digit: keyboard UN/DOWN key modify selection 0: Invalid 1: Modify frequency setting by key board numbers F00.08 2: Modify PID give setting by key board numbers F11.01</p> <p>LED "00" digit: power off storage selection 0: No save frequency after power off 1: Save frequency after power off</p> <p>LED "000" digit: action limit 0: Operation stop for adjusting 1: Adjusting only in operation, stop for holding 2: Adjusting in operation, stop for clearing</p>	0011	○	0x409
F04.10- F04.13	Reserved				
F04.14	The display content of the first line in running state	<p>LED "0" and "00" digit: display the first group 00~63</p> <p>LED "000" and "0000" digit: display the second group 00~63</p>	1101	●	0x40E
F04.15	The display content of the first line in running	Same as above	0402	●	0x40F
F04.16	The display content of the first line in stop	Same as above	1100	●	0x410
F04.17	The display content of the first line in stop	Same as above	0402	●	0x411
F04.18	The display content of the second line in	Same as above	0402	●	0x412
F04.19	The display content of the second line in	Same as above	1210	●	0x413
F04.20	The display content of the second line in stop	Same as above	0402	●	0x414
F04.21	The display content of the second line in stop	Same as above	1210	●	0x415

F04.22	Keyboard display item setting	LED “0” digit: output frequency selection 0: Aim frequency 1: Running frequency LED “000” digit: power display dimension 0: Power display percentage (%) 1: Power display kilowatt (KW)	0000	●	0x416
F04.23	Monitor display selection	LED “0” digit: C00.00-C00.39 0: Normal 1: Debugging LED “00” digit: C00.40-C00.69 0: No display 1: Normal display	0000	●	0x417
F04.24	Rotate speed display coefficient	0.0~500.0%	0000	●	0x418
F04.25	Power display	0.0~500.0%	100.0%	●	0x419
F04.26	Alarm selection 1	LED “0” digit: E.EEP fault (EEPROM storage fault) 0: Alarm and free stop 1: Alarm and continue operation	100.0%	●	0x41A
F04.27	Reserved		0000	○	0x41B
F04.28	Fan control	0:After power on the fan runs 1: Stop associated with temperature, running is rotary 2: Running associated with temperature, stop while the fan stops	1	●	0x41C
F04.29	Energy braking enable	0:Off 1:On	0	●	0x41D
F04.30	Energy braking operation voltage	115.0%~140.0%	125.0%	●	0x41E
F04.31	Energy braking	0.0~100.0%	10.0%	●	0x41F
F04.32	PWM carrier	0.7~16.0kHz	Model	※	0x420
F04.33	PWM control mode	LED “0” digit: carrier associated with temperature 0: Temperature independent 1: Temperature dependent LED “00” digit : carrier associated with output frequency 0:not associated 1: associated LED “000” digit: random PWM valid 0: Prohibited 1: Valid LED “0000” digit: PWM modulation mode 0: Only use three-phase modulation 1: Two-phase and three-phase modulation automatically switched	1111	●	0x421

Motor Parameters

NO.	Function description	Range of settings and definition	Factory default	Feature	Address
F05.00	Motor mode	0: Asynchronous motors (AM) 1: Permanent magnet synchronous	0	×	0x500
F05.01	Number of motor poles	2~98	4	○	0x501
F05.02	Motor rated power	0.1~1000.0kW	Model	※	0x502
F05.03	Motor rated frequency	0.01~max frequency	Model	※	0x503
F05.04	Motor rated speed	1~6500rpm	Model	※	0x504
F05.05	Motor rated voltage	1~1500V	Model	※	0x505
F05.06	Motor rated current	0.1~3000.0A	Model	※	0x506
F05.07	Asynchronous motor no-load current	0.1~3000.0A	Model set	※	0x507
F05.08	Asynchronous motor stator resistance	0.01~50.00%	Model set	※	0x508
F05.09	Asynchronous motor rotor resistance	0.01~50.00%	Model set	※	0x509
F05.10	Asynchronous motor stator leakage	0.01~50.00%	Model set	※	0x50A
F05.11	Asynchronous motor stator inductance	0.1~2000.0%	Model set	※	0x50B
F05.12	synchronous motor stator resistance	0.01~50.00%	Model set	※	0x50C
F05.13	Synchronous machine d axis inductance	0.01~200.00%	Model set	※	0x50D
F05.14	Synchronous machine q axis inductance	0.01~200.00%	Model set	※	0x50E
F05.15	Synchronous machine back EMF	1~1500V	Model set	※	0x50F
F05.16	Synchronous machine encoder installation	0.0°~360.0°	Model set	※	0x510
F05.17 -F05.19	Reserved				
F05.20	Motor parameters self-adjustment selections	0: No operation 1: Rotary type self-tuning 2: Static type self-tuning 3: Stator resistance self-tuning	0	○	0x514

F05.21	Synchronous machine poles searching function	LED “0” digit: closed-loop vector 0: OFF 1: ON 2: On, only operate firstly when electrify LED “00” digit: open-loop vector 0: OFF 1: ON	0010	○	0x515
F05.22 -F05.29	Reserved				
F05.30	Speed feedback or encoder mode	LED “0” digit: encoder mode 0: Common ABZ encoder 1: Resolver encoder LED “00” digit: encoder direction 0: same direction 1: reverse direction LED “000” digit: wire break inspection 0: OFF 1: ON LED “0000” digit: Z pulse correction enabled 0: OFF 1: ON	0000	○	0x51E
F05.31	ABZ encoder lines	0-10000	1024	○	0x51F
F05.32	wire break inspection	0.100-60.000s	2.000s	●	0x520
F05.33	Resolver encoder	2~128	2	○	0x521
F05.34	Numerator of encoder transmission ratio	1~32767	1	○	0x522
F05.35	Denominator of encoder transmission	1~32767	1	○	0x523
F05.36	First-order filter of encoder speed	0.0~100.0ms	1.0ms	●	0x524
F05.37 -F05.49	Reserved				

Motor VC Parameters

NO.	Function description	Range of settings and definition	Factory default	Feature	Address
F06.00	ASR(speed loop) proportional gain 1	0.01~100.00	10.00	●	0x600
F06.01	ASR integral time 1	0.000~6.000s	0.200s	●	0x601
F06.02	ASR filter time1	0.0~100.0ms	0.0ms	●	0x602
F06.03	ASR switch frequency 1	0.00 ~ Max	0.00Hz	●	0x603
F06.04	ASR (speed loop) proportional gain 2	0.01~100.00	10.00	●	0x604

F06.05	ASR (speed loop) integral time 2	0.000~6.000s	0.200s	●	0x605
F06.06	ASR filter time 2	0.0~100.0ms	0.0ms	●	0x606
F06.07	ASR switch frequency 2	0.00 ~ Max	5.00Hz	●	0x607
F06.08	Electric motor torque limit	0.0~250.0%	180.0%	●	0x608
F06.09	Power generation torque limit	0.0~250.0%	180.0%	●	0x609
F06.10	Current loop D-axis proportional gain	0.001~4.000	1.000	●	0x60A
F06.11	Current loop D-axis integral gain	0.001~4.000	1.000	●	0x60B
F06.12	Current loop Q-axis proportional gain	0.001~4.000	1.000	●	0x60C
F06.13	Current loop Q-axis integral gain	0.001~4.000	1.000	●	0x60D
F06.15	Vector control motor slip compensation	0.0~250.0%	100.0%	●	0x60F
F06.16	Vector control start torque	0.0~250.0%			
F06.17	Reserved				
F06.18	Position compensation control	0:OFF 1:ON	10.0%	○	0x613
F06.19	compensation gain	0.0~250.0%	0.1%	○	0x614
F06.20	compensation limit	0.0~100.0%	10.0%	○	0x615
F06.21	compensation effective range	0.0~100.0%	100.0%	○	0x616
F06.22	Over excitation braking gain	0.0~500.0%	100.0%	○	0x617
F06.23	Over excitation braking amplitude limit	0.0~250.0%	0	○	0x618
F06.24	Vector control energy saving function	0:OFF 1:ON	50.0%	●	0x619
F06.25	Energy saving control gain	0.0~80.0%	0.010s	●	0x61A
F06.26	Energy saving control low-pass filter	0.000~6.000s	200.0%	●	0x61B
F06.27	Motor constant power area power limit	0.0~250.0%	60.0%	○	0x61C
F06.28	Motor weak magnetic current upper limit	0.0~250.0%	10.0%	●	0x61D
F06.29	Motor weak magnetic feed forward gain	0.0~200.0%	10.0%	●	0x61E
F06.30	Motor weak magnetic gain	0.0~500.0%	10.0%	●	0x620
F06.32	MTPA gain	0.0~500.0%	100.0%	●	0x621
F06.33	MTPA filter time	0.0~100.0ms	1.0ms	●	0x621
F06.34	Reserved				
F06.35	Low frequency pull in current	0.0~100.0%	10.0%	●	0x623
F06.36	High frequency pull in current	0.0~100.0%	10.0%	●	0x624
F06.37	Frequency of current pulled in	0.0~100.0%	10.0%	●	0x625

Torque Control Parameters

NO.	Function description	Range of settings and definition		Factory default	Feature	Address
F07.00	Torque/Speed control	0:Speed control 1:Torque control Torque/Speed control		0	●	0x700
F07.01	Torque given channels selection	0: keyboard number given 1: reserved 2: AI1 3: AI2	4: reserved 5: PUL 6: RS485 communication given 7: Optional card	0	●	0x701
F07.02	Torque keyboard number setting	0~100.0%		0.0%	●	0x702
F07.03	Torque input lower limit	0~100.00%		0.00%	●	0x703
F07.04	Lower limit corresponding setting	-200.00%~200.00%		0.00%	●	0x704
F07.05	Torque input upper limit	0~100.00%		100.00%	●	0x705
F07.06	Upper limit corresponding setting	-200.00%~200.00%		100.00%	●	0x706
F07.07	Given first-order filter time	0.000~6.000S		0.100s	●	0x707
F07.08	Output torque upper limit	0~200.0%		150.0%	●	0x708
F07.09	Output torque lower limit	0~200.0%		0%	●	0x709
F07.10	Torque control FWD speed limit selection	0: function code F07.12setting 1: reserved 2:AI1 × F07.12 3: AI2 × F07.12 4: reserved 5:PUL × F07.12 6: RS485 communication given × F07.12		0	●	0x70A
F07.11	Torque control REV speed limit selection	0: function code F07.13setting 1: reserved 2:AI1 × F07.13 3: AI2 × F07.13 4: reserved 5:PUL × F07.13 6: RS485 communication given × F07.13 7: Optional card × F07.13		0	●	0x70B
F07.12	Torque control FWD max speed limit	0.0~100.0%		100.0%	●	0x70C
F07.13	Torque control REV max speed limit	0.0~100.0%		100.0%	●	0x70D

Motor V/F Control Parameter

NO.	Function description	Range of settings and definition		Factory default	Feature	Address
F08.00	Linear V/F curve selection	0: Beeline VF curve 1-9: 1.1-1.9 th power VF curve respectively 10: square VF curve 11: self-defined VF curve		0	○	0x800
F08.01	Self-setting voltage V1	0.0~100.0%		3.0%	○	0x801
F08.02	Self-setting frequency F01	0.00~max frequency		1.00Hz	○	0x802
F08.03	Self-setting voltage V2	0.0~100.0%		28.0%	○	0x803
F08.04	Self-setting frequency F02	0.00~max frequency		10.00Hz	○	0x804
F08.05	Self-setting voltage V3	0.0~100.0%		55.0%	○	0x805
F08.06	Self-setting frequency F03	0.00~max frequency		25.00Hz	○	0x806
F08.07	Self-setting voltage V4	0.0~100.0%		78.0%	○	0x807
F08.08	Self-setting frequency F04	0.00~max frequency		37.50Hz	○	0x808
F08.09	Self-setting voltage V5	0.0~100.0%		100.0%	○	0x809
F08.10	Self-setting frequency F05	0.00~max frequency		50.00Hz	○	0x80A
F08.11	Output voltage percentage	25.0~120.0%		100.0%	○	0x80B
F08.12	Torque boost	0.0~30.0%		0.0%	●	0x80C
F08.13	Torque boost cut-off frequency	0.0~100.0%		100.0%	●	0x80D
F08.14	Slip compensation gain	0.0~200.0%		100.0%	●	0x80E
F08.15	Slip compensation limit	0.0~300.0%		100.0%	●	0x80F
F08.16	Slip compensation filter	0.000~6.000s		0.200s	●	0x810
F08.17	oscillation suppression	0.0~900.0%		100.0%	●	0x811
F08.19	Auto energy saving control	0: off	1:on	0	○	0x813
F08.20	Energy saving lower limit frequency	0.0~50.00Hz		15.00Hz	○	0x814
F08.21	Energy saving lower limit voltage	20.0~100.0%		50.0%	○	0x815
F08.22	Energy saving regulation rate of voltage	0.000~0.200V/MS		0.010V/M S	●	0x816
F08.23	Energy saving recovery rate of voltage	0.000~2.000V/MS		0.200V/M S	●	0x817
F08.24- F08.29	Reserved					
F08.30	Output voltage source of voltage-frequency separation	0: function code F8.31 setting 1: Reserved 2: AI1 3: AI2	4: Reserved 5: PUL 6: PID output 7: RS485 8: Optional	0	●	0x81E
F08.31	Output voltage source of voltage-frequency separation number setting	0.0%~100.0%		0.0%	●	0x81F

F08.32	Output voltage source of voltage-frequency separation ACC time	0.0~100.00s	10.00s	●	0x820
F08.33	Output voltage source of voltage-frequency separation DEC time	0.0~100.00s	10.00s	●	0x821
F08.34	voltage-frequency separation stop time	0:Output voltage and frequency ACC/DEC no interaction 1: Output voltage down to 0V, then output frequency start to decrease	0	●	0x822

Protection and Malfunction Parameter Group

NO.	Function description	Range of settings and definition	Factor y	Feature	Address
F10.00	OC suppression function	0: Suppression valid 1: ACC/DEC valid, constant speed invalid	0	●	0xA00
F10.01	OC suppression	0.0~300.0%	160.0	●	0xA01
F10.02	OC suppression	0.0~500.0%	100.0	●	0xA02
F10.03	Current hardware protection settings	LED "0" digit: CBC(cycle by cycle, limit current according to its waveform) 0: off 1: on LED"00" digit: OC protection interference suppression 0: off 1: First grade 2: Second grade LED"000"digit: SC protection interference suppression 0: off 1: First grade 2: Second grade LED"0000"digit: Reserved	0001	○	0xA03
F10.04	Reserved				0xA04
F10.05	Hardware	0: Invalid 1: Valid			0xA05
F10.06	Bus over voltage suppression function	LED"0" digit: Over voltage suppression 0: Invalid 1: Valid in DEC 2: Valid both in ACC/DEC LED"00" digit: Over-excitation control 0: off 1: on LED"000"/"0000": Reserved	0012	○	0xA06
F10.07	Bus over voltage suppression point	110.0~150.0%	128.0 %	※	0xA07
F10.08	Bus over voltage suppression gain	0.0~500.0%	100.0 %	●	0xA08

F10.09	Bus under voltage suppression	0: Invalid 1: Valid	0	○	0xA09
F10.10	Bus under voltage suppression point	60.0~90.0%	80.0%	※	0xA0A
F10.11	Bus under voltage suppression gain	0.0~500.0%	100.0 %	●	0xA0B
F10.12	Bus under voltage protection point	60.0~90.0%	60.0%	※	0xA0C
F10.13	Phase missing	0~100%	10.0	○	0xA0D
F10.14	Short-circuit detection after power on	LED“0” digit: Earth short-circuit detection after power on 0: off 1: on LED“00” digit: Fan short-circuit detection after power 0: off 1: on	11	○	0xA0E
F10.15	phase missing protection	LED“0” digit: Output phase missing protection 0: off 1: on LED“00” digit: Input phase missing protection 0: off 1: Open Alarm 2: Open Fault(STOP VFD) LED“000” /“0000” digit: Reserved	0021	○	0xA0F
F10.16	Motor overload protection curve	0.0~250.0%	100.0 %	○	0xA10

F10.17	Load pre alarm detection setting	<p>LED“0” digit: Detection selection(Protection 1) 0: Not detection 1: Detected load is too large 2: Detected load is too large only at constant speed 3: Detected underloaded 4: Detected underloaded only at constant speed</p> <p>LED”00” digit: Alarm selection 0: alarm and continue operation 1: Fault protection and free stop</p> <p>LED”000” digit: Detection selection (Protection 2) 0: Not detection 1: Detected load is too large 2: Detected load is too large only at constant speed 3: Detected underloaded 4: Detected underloaded only at constant speed</p> <p>LED “0000” digit: Alarm selection 0: Alarm and continue operation 1: Fault warn and free stop</p>	0000	○	0xA11
		<p>constant speed 3: Detected underloaded 4: Detected underloaded only at constant speed</p> <p>LED “0000” digit: Alarm selection 0: Alarm and continue operation 1: Fault warn and free stop</p>			
F10.18	Pre alarm detection level 1	0.0~200.0%	130.0 %	○	0xA12
F10.19	Load pre alarm detection time 1	0.0~60.0s	5.0s	○	0xA13
F10.20	Pre alarm detection level 2	.0~200.0%	30.0%	○	0xA14
F10.21	Load pre alarm detection time 2	0.0~60.0s	5.0s	○	0xA15
F10.22	Reserved				0xA16

F10.23	Protection action of speed bias excess	<p>LED “0” digit: Detection selection 0: Not detected 1: Detected only at constant speed 2: Detecting</p> <p>LED “00” digit: Alarm selection 0: Free stop and report fault 1: Alarm and continue operation</p> <p>LED “000”/”0000” digit: Reserved</p>	0000	○	0xA17
F10.24	Detection threshold when speed bias	0.0~60.0%	10.0%	○	0xA18
F10.25	Detection time when speed bias	0.0~60.0s	2.0s	○	0xA19
F10.26	Stall protection action	<p>LED “0” digit: Detection selection 0: Not detected 1: Detected at constant speed 2: Detecting</p> <p>LED “00” digit: Alarm selection 0: Free stop and report fault 1: Alarm and continue operation</p> <p>LED “000” digit: Reserved LED “0000” digit: Reserved</p>	0000	○	0xA1A
F10.27	Stall detection	0.0~150.0%	110.0	○	0xA1B
F10.28	Stall detection time	0.000~2.000s	0.010s	○	0xA1C
F10.29	Motor overshoot Protection	0~200°C		○	0xA1D
F10.30	Motor overshoot Pre alarm threshold	0~200°C		○	0xA1E
F10.31-F10.37	Reserved				
F10.38	Malfunction self-recovery times	0~5	0	○	0xA26
F10.39	Malfunction self-recovery	0.1~100.0s	1.0s	○	0xA27

PID Process Control Parameter Group

NO.	Function description	Range of settings and definition		Factory default	Feature	Address
F11.00	PID Controller given signal source	0: Keypad digit PID given 1: Reserved 2: AI1 3: AI2 4: Reserved	5: PUL 6: RS485 7: Option card 8: Terminal selection	0	●	0xB00
F11.01	Keyboard digit PID given / feedback	0.00~100.0%		50.0%	●	0xB01
F11.02	PID given changing	0.00~60.00s		1.00s	●	0xB02

F11.03	PID controller feedback signal source	0: Keypad digital PID feedback 1: Reserved 2: AI1 3: AI2	4: Reserved 5: PUL 6: RS485 7: Option card 8: Terminal selection	2	●	0xB03
F11.04	Feedback signal filter	0.000~6.000s		0.010s	●	0xB04
F11.05	Feedback signal gain	0.00~10.00		1.00	●	0xB05
F11.06	Given and feedback	0~100.0		100.0	●	0xB06
F11.07	PID control selection	LED"0" digit: Feedback feature selection 0: Positive feature 1: Negative feature LED"00"/"000" digit: Reserved LED"0000" digit: Differential adjustment properties 0: Differential bias 1: Differential of feedback		0100	●	0xB07
F11.08	PID preset output	0.0~100.0%		100.0%	●	0xB08
F11.09	PID preset output running time	0.0~6500.0s		0.0s	●	0xB09
F11.10	PID control deviation	0.0~100.0%		0.0%	●	0xB0A
F11.11	Proportional gain P1	0.000~8.000		0.100	●	0xB0B
F11.12	Integral time I1	0.0~600.0s		1.0s	●	0xB0C
F11.13	Differential time D1	0.000~6.000s		0.000s	●	0xB0D
F11.14	Proportional gain P2	0.000~8.000		0.100	●	0xB0E
F11.15	Integral time I2	0.0~600.0s		1.0s	●	0xB0F
F11.16	Differential gain D2	0.000~6.000s		0.000s	●	0xB10
F11.17	PID Parameter switching condition	0: No switch 1: Use DI terminal to switch 2: Switch according to deviation		0	●	0xB11
F11.18	Low value of switching deviation	0.0~100.0%		20.0%	●	0xB12
F11.19	High value of switching deviation	0.0~100.0%		80.0%	●	0xB13
F11.20	Reserved					0xB14
F11.21	Differential limit	0.0~100.0%		5.0%	●	0xB15
F11.22	PID output upper limit	0.0~100.0%		100.0%	●	0xB16
F11.23	PID output lower limit	-100.0~F11.19		0.0%	●	0xB17
F11.24	PID output filter time	0.000~6.000s		0.000s	●	0xB18
F11.25	Feedback wire break detection time	0.0~120.0s		1.0s	●	0xB19

F11.26	Feedback wire break action selection	0: Go on PID operation without alarm 1: Stop and alarm malfunction 2: continue to PID operation and output alarm signal 3: Run at the current frequency and output alarm signal	0	●	0xB1A
F11.27	Wire break alarm	0.0~100.0%	100.0%	●	0xB1B
F11.28	Wire break alarm	0.0~100.0%	0.0%	●	0xB1C
F11.29	Close-loop suspend detection threshold	0.0~100.0%	0.0%	●	0xB1D
F11.30	Close-loop suspend detection time	0.0~600.0s	1.0s	●	0xB1E

Multi-Speed and PLC Function Parameter Group

NO.	Function description	Range of setting and definition	Factory default	Feature	Address
F12.00	PLC Speed 1	0.00~Max frequency	10.00Hz	●	0xC00
F12.01	PLC Speed 2	0.00~Max frequency	20.00Hz	●	0xC01
F12.02	PLC Speed 3	0.00~Max frequency	30.00Hz	●	0xC02
F12.03	PLC Speed 4	0.00~Max frequency	40.00Hz	●	0xC03
F12.04	PLC Speed 5	0.00~Max frequency	50.00Hz	●	0xC04
F12.05	PLC Speed 6	0.00~Max frequency	40.00Hz	●	0xC05
F12.06	PLC Speed 7	0.00~Max frequency	30.00Hz	●	0xC06
F12.23	PLC Speed 8	0.00~Max frequency	20.00Hz	●	0xC07
F12.08	PLC Speed 9	0.00~Max frequency	10.00Hz	●	0xC08
F12.09	PLC Speed 10	0.00~Max frequency	20.00Hz	●	0xC09
F12.10	PLC Speed 11	0.00~Max frequency	30.00Hz	●	0xC0A
F12.11	PLC Speed 12	0.00~Max frequency	40.00Hz	●	0xC0B
F12.12	PLC Speed 13	0.00~Max frequency	50.00Hz	●	0xC0C
F12.13	PLC Speed 14	0.00~Max frequency	40.00Hz	●	0xC0D
F12.14	PLC Speed 15	0.00~Max frequency	30.00Hz	●	0xC0E

F12.15	PLC Running mode selection	LED"0" digit: cycle mode 0: Stop after single cycle 1: Continuous cycles 2: Keep final value after single cycle LED"00" digit: Time unit 0: second 1: minute 2:hour LED"000" digit: Power down memory 0: Not save 1: save LED"0000" digit: Start mode 0: Restart from the 1st stage 1: Restart from the stop stage 2: Continue running from the time when stop	0000	●	0xC0F
F12.16	PLC 1st step running	0.0~6500.0(s/m/h)	10.0	●	0xC10
F12.17	PLC 2nd step running	0.0~6500.0(s/m/h)	10.0	●	0xC11
F12.18	PLC 3rd step running	0.0~6500.0(s/m/h)	10.0	●	0xC12
F12.19	PLC 4thstep running time	0.0~6500.0(s/m/h)	10.0	●	0xC13
F12.20	PLC 5th step running	0.0~6500.0(s/m/h)	10.0	●	0xC14
F12.21	PLC 6th step running	0.0~6500.0(s/m/h)	10.0	●	0xC15
F12.22	PLC 7th step running	0.0~6500.0(s/m/h)	10.0	●	0xC16
F12.23	PLC 8th step running	0.0~6500.0(s/m/h)	10.0	●	0xC17
F12.24	PLC 9th step running	0.0~6500.0(s/m/h)	10.0	●	0xC18
F12.25	PLC 10th step running	0.0~6500.0(s/m/h)	10.0	●	0xC19
F12.26	PLC 11th step running	0.0~6500.0(s/m/h)	10.0	●	0xC1A
F12.27	PLC 12th step running	0.0~6500.0(s/m/h)	10.0	●	0xC1B
F12.28	PLC 13th step running	0.0~6500.0(s/m/h)	10.0	●	0xC1C
F12.29	PLC 14th step running	0.0~6500.0(s/m/h)	10.0	●	0xC1D
F12.30	PLC 15th step running	0.0~6500.0(s/m/h)	10.0	●	0xC1E
F12.31	PLC 1st-15th step direction and ADD/DEC time	LED"0" digit: current step run direction 0: FWD 1: REV LED"00" digit: ACC/DEC time in this step 0: ACC/DEC time 1 1: ACC/DEC time 2 2: ACC/DEC time 3 3: ACC/DEC time 4 LED"000" digit: Reserved LED"0000" digit: Reserved	0000	●	0xC1F
F12.32			0000	●	0xC20
F12.33			0000	●	0xC21
F12.34			0000	●	0xC22
F12.35			0000	●	0xC23
F12.36			0000	●	0xC24
F12.37			0000	●	0xC25
F12.38			0000	●	0xC26
F12.39			0000	●	0xC27
F12.40			0000	●	0xC28
F12.41			0000	●	0xC29
F12.42			0000	●	0xC2A
F12.43			0000	●	0xC2B
F12.44			0000	●	0xC2C
F12.45			0000	●	0xC2D

F12.46 - F12.48	Reserved					
F12.49	Swing frequency control	0: invalid	1: valid	0	●	0xC31
F12.50	Swing frequency amplitude	0: Relative to central frequency 1: Relative to max frequency		0	●	0xC32
F12.51	Reserved	0.0~100.0%		10.0%	●	0xC34
F12.52	Swing frequency					
F12.53	Jump frequency	0.0~50.0%		10.0%	●	
F12.54	Swing frequency rising	0.00~650.00s		5.00s	●	0xC36
F12.55	Swing frequency falling	0.00~650.00s		5.00s	●	0xC37

Communication Control Function Parameter Group

NO.	Function description	Range of setting and definition		Factory default	Feature	Address
F13.00	Main-slave machine selection	LED "0" digit: Modbus main-slave selection 0: Slave machine 1: Main machine LED "00" / "000" / "0000" digit: reserved		0000	○	0xD00
F13.01	485 communication	1~247		1	○	0xD01
F13.02	Communication baud rate selection	LED "0" digit: 485 communication 0: 1200 bps 1: 2400 bps 2: 4800 bps 3: 9600 bps 4: 19200 bps 5: 38400 bps LED "00" / "000" / "0000" digit: reserved		0003	○	0xD02
F13.03	Modbus data format	0: (N,8,1) format 1: (E,8,1) format 2: (O,8,1) format	3: (N,8,2) format 4: (E,8,2) format 5: (O,8,2) format	0	○	0xD03
F13.04	Communication ratio	0.00~5.00		1.00	●	0xD04
F13.05	Modbus communication answer	0~500ms		0ms	●	0xD05
F13.06	Modbus communication	0.1~100.0s		1.0s	●	0xD06

F13.07	Modbus communication fault action mode selection	0: No checked overtime fault 1: alarm and stop freely 2: Alarm and continue running 3: Forced stop	0	●	0xD07
F13.08	Modbus Responds dispose	0:Write operation with response 1: Write operation without response	0	●	0xD08
F13.09	Main machine sending selection	LED“0”digit: the first group transmitting frame selection 0: Invalid 1: Main machine run command 2: Main machine given frequency 3: Main machine output frequency 4: Main machine upper limit frequency 5: Main machine given torque 6: Main machine output torque 7/8: Reserved 9: Main machine given PID A: Main machine feedback PID LED“00”digit: the second group transmitting frame selection LED“000”digit: the third group transmitting frame selection LED“0000”digit: the fourth group transmitting frame selection Same as above	0031	●	0xD09
F13.10	RS485 Communication port configuration	0: Modbus communication 1: serial port communication	0	●	0xD0A

★ Photovoltaic Pump Special Parameters

Function code	Function name	Setting range and definition	Default setting	property	Comm. Add
F14.00	Solar pump drive control mode	0 : Variable frequency control mode 1 : CVT mode for solar 2 : MPPT mode for solar	2	○	0xE00
F14.01	Running control mode	0 : Stop 1 : Running 2 : Sleep 3 : Low speed protection 4 : Dry run protection 5 : Over current protection 6 : Minimum power protection	Read only		0xE01
F14.02	VOC voltage (display)	0.0 ~ 999.9V	Read only		0xE02

F14.03	CVT target voltage	70.0 ~ 95.0%	81.0%	●	0xE03
F14.04	MPPT upper limit voltage	20.0 ~ 200.0%	100.0%	●	0xE04
F14.05	MPPT lower limit voltage	20.0 ~ 200.0%	50.0%	●	0xE05
F14.06	Frequency adjusting gain	0.1 ~ 500.0%	10.0% (AM) 40.0% (PMSM)	●	0xE06
F14.07	MPPT search interval	0.1 ~ 100.0	1.0s	●	0xE07
F14.08	MPPT regulating gain	0 ~ 9999	100	●	0xE08
F14.09	Quick-drop frequency gain	0 ~ 20	2	●	0xE09
F14.10	Frequency adjusting filter time	0.001 ~ 2.000 s	0.001	●	0xE0A
F14.11	Go to sleep mode voltage	0 ~ 1000V	0V	●	0xE0B
F14.12	Wake up restore voltage	0 ~ 1000V	400V	●	0xE0C
F14.13	Sleeping stop restore waiting time	0.0 ~ 3000.0s	10.0s	●	0xE0D
F14.14	Low speed protection detect frequency	0.00 ~ 300.00Hz	10.00Hz	●	0xE0E
F14.15	Low speed protection detect time	0.0 ~ 3000.0s	10.0s	●	0xE0F
F14.16	Low speed protection restore working time	0.0 ~ 3000.0s	10.0s	●	0xE10
F14.17	Dry run protection detect current	0.0 ~ 999.9A	0.0A	●	0xE11
F14.18	Dry run protection detect time	0.0 ~ 3000.0s	10.0s	●	0xE12
F14.19	Dry run auto restore working time	0.0 ~ 3000.0s	10.0s	●	0xE13
F14.20	Over current point setting	0.0 ~ 999.9A	0.0A	●	0xE14
F14.21	Over current protection detect time	0.0 ~ 3000.0s	10.0s	●	0xE15

F14.22	Over current protection auto restore working time	0.0 ~ 3000.0s	10.0s	●	0xE16
F14.23	Input minimum power protection power point setting	0.00 ~ 650.00kw	0.00kw	●	0xE17
F14.24	Minimum power protection detect time	0.0 ~ 3000.0s	10.0s	●	0xE18
F14.25	Minimum power protection auto restore working time	0.0 ~ 3000.0s	10.0s	●	0xE19
F14.26	Fault alarm restore mode	0 : Auto reset;1 : Reset by manual LED0 : Low speed protection LED1 : Dry run LED2 : Over current protection LED3: Minimum power protection	0000	●	0xE1A
F14.27	Water fulfilled detect time	0.0s ~ 3000.0s	10.0s	●	0xE1B
F14.28	Water fulfilled restore time	0.0s ~ 3000.0s	10.0s	●	0xE1C
F14.29	reserve			●	0xE1D
F14.30	DC current revise offset	0.00 ~ 99.99A	0.01A	●	0xE1E
F14.31	DC current revise proportion gain	0.0 ~ 999.9%	100.0%	●	0xE1F
F14.32	Power curve point 0	0.00 ~ 99.99kw	0.50kw	●	0xE20
F14.33	Power curve point 1	0.00 ~ 99.99kw	1.00kw	●	0xE21
F14.34	Power curve point 2	0.00 ~ 99.99kw	1.50kw	●	0xE22
F14.35	Power curve point 3	0.00 ~ 99.99kw	2.00kw	●	0xE23
F14.36	Power curve point 4	0.00 ~ 99.99kw	2.50kw	●	0xE24
F14.37	Flow curve point 0	0.0 ~ 999.9m3/h	0.0 m3/h	●	0xE25
F14.38	Flow curve point 1	0.0 ~ 999.9m3/h	5.0 m3/h	●	0xE26
F14.39	Flow curve point 2	0.0 ~ 999.9m3/h	10.0 m3/h	●	0xE27
F14.40	Flow curve point 3	0.0 ~ 999.9m3/h	15.0 m3/h	●	0xE28

F14.41	Flow curve point 4	0.0 ~ 999.9m3/h	20.0 m3/h	●	0xE29
F14.42	Flow calculating revise offset	0.0 ~ 999.9m3	0.0m3	●	0xE30
F14.43	Flow calculating revise gain	0.0 ~ 999.9%	100.0%	●	0xE31
F14.44	Power per day/ generated power per day reset period	0.0 ~ 24.0h	7.0h	●	0xE32
F14.45	Reserved				
F14.46	Photovoltaic pump function selection 1	0 : Invalid 1 : Valid LED0 : Constant torque frequency limit selection LED1 : Reserved LED2 : Voltage rising update Voc voltage LED3: Fast frequency falling function	1100H	●	0xE34
F14.47	Fast frequency falling threshold	3.0% ~ 15.0%	5.0%	●	0xE35
F14.48	Constant torque frequency limit coefficient	80.0% ~ 150.0%	100.0%	●	0xE36
F14.49	Sudden voltage increase threshold	0.0% ~ 20.0%	5.0%	●	0xE37
F14.50	Reserved				

Terminal of Input and Output Function Selection

X	Function Specification	X	Function Specification	X	Function
0	No function	16-1	Multispeed terminal 1-4	41	Timer clear terminal
1	FWD	20	PID control cancel	42	Counter input
2	REV	21	PID control pause	43	Counter clear
3	3-line running(Xi)	22	PID trait switch	44	DC braking
4	FWD JOG	23	PID gain switch	45	Pre excitation
5	REV JOG	24- 26	PID given switch 1-3	48	Command channel switch to keyboard
6	Free stop	27- 29	PID feedback switch1-3	49	Command channel switch to terminal
7	Emergency stop	30	PLC pause	50	Command channel switch to
8	Malfunction reset	31	PLC restart	51	Command channel switch to expansion
9	External malfunction input	32	ACC/DEC time selection	52	Operation banned

10	Frequency UP	33	ACC/DEC time selection	53	Forward banned
11	Frequency DW	34	ACC/DEC pause	54	Reverse banned
12	UP/DW clear	35	Swing frequency input	60	Speed torque control
13	Switch channel A to channel B	36	Swing frequency	61	Position control
14	Channel combination switch to	37	Swing frequency reset	No Definition Code:38-39,46-47, 55-59:Reserved	
15	Channel combination switch to	40	Timer trigger terminal		
Y	Function Specification	Y	Function Specification	Y	Function
0	No output	1	FWD running	2	REV running
3	FWD running	4	Fault warning 1,enable output including fault reset auto period	5	Fault trip alarm 2(no alarm when fault self-recovery)
6	External fault stop	7	External fault stop Under voltage	8	Finish ready for running
9	Output frequency level detection 1(FDT1)	10	Output frequency level detection 2(FDT2)	11	Reach given frequency
12	0 speed running	13	Reach upper limit	14	Reach lower
15	Program running circle completed	16	Program running segment completed	17	PID feedback exceeds upper limit
18	PID feedback under lower limit	19	PID feedback sensor wires	21	Timer time arrived
22	Counter reaching max value	23	Counter reach set value	24	Braking
25	PG feedback wire break	26	Emergency stop	27	Load pre-alarm
28	Load pre-alarm output 2	29	Reserved	30	RS485 given

C01-Malfunction Diagnosis Monitor Group

Function code	Function name	Unit and definition	Address
C01.00	Malfunction types	See fault code table	0x2200
C01.01	Malfunction diagnosis information	See fault code table	0x2201
C01.02	Malfunction running frequency	0.00~Max frequency	0x2202
C01.03	Malfunction output Voltage	0~1500V	0x2203
C01.04	Malfunction out Current	0.1~1000.0A	0x2204
C01.05	Malfunction Bus Voltage	0~3000V	0x2205
C01.06	Malfunction module temperature	0~100℃	0x2206
C01.07	Malfunction machine state	LED “0” digit: Running direction 0: FWD 1: REV LED “00” digit: Running status 0: Stop 1: ACC 2: DEC 3:Constant speed LED “000” digit: Reserved LED “0000” digit: Reserved	0x2207
C01.08	Malfunction input terminal status	See input terminal chart	0x2208
C01.09	Malfunction output terminal status	See output terminal chart	0x2209
C01.10	The last malfunction types	Please see malfunction code table	0x220A

C01.11	The first diagnosis information	Please see malfunction code table	0x220B
C01.12	The last malfunction running frequency	0.00~Maxfrequency	0x220C
C01.13	The last malfunction output voltage	0~1500V	0x220D
C01.14	The last malfunction output current	0.1~2000.0A	0x220E
C01.15	The last malfunction bus voltage	0~3000V	0x220F
C01.16	The last malfunction module temperature	0~100℃	0x2210
C01.17	The last malfunction machine state	LED "0" digit: Running direction 0: FWD 1: REV LED "00" digit: Running status 0: Stop 1: Constant speed 2: ACC 3: DEC LED "000" digit: Reserved LED "0000" digit: Reserved	0x2211
C01.18	The last malfunction input terminal state	See input terminal chart	0x2212
C01.19	The last malfunction output terminal state	See output terminal chart	0x2213
C01.20	The first two malfunction types	Please see malfunction information code table	0x2214
C01.21	The first two diagnosis information		0x2215
C01.22	The first three malfunction types		0x2216
C01.23	The first three diagnosis information		0x2217

★ Photovoltaic Pump Special Monitor Parameters

Function code	Function name	Setting range and definition	Default setting	property	Comm. Add
C02.00	Frequency reference	0.01Hz	Read only		2300H
C02.01	Output frequency	0.01Hz	Read only		2301H
C02.02	Output current	0.1A	Read only		2302H
C02.04	Output voltage	0.1V	Read only		2304H
C02.10	Output power	0.01kw	Read only		230AH
C02.11	DC bus voltage	0.1V	Read only		230BH
C02.12	Module temperature 1	0.1℃	Read only		230CH
C02.30	DC current	0.01A	Read only		231EH
C02.31	Flow speed	0.1 m3/h	Read only		231FH

C02.32	Voc voltage	0.1 V	Read only		2320H
C02.33	Flow per day	0.1 m ³	Read only		2321H
C02.34	Cumulative total flow(low position)	0.1m ³	Read only		2322H
C02.35	Cumulative total flow(high position)	0.1km ³	Read only		2323H
C02.36	Generated power per day	0.01kwh	Read only		2324H
C02.37	Cumulative total generated power (low position)	0.01kwh	Read only		2325H
C02.38	Cumulative total generated power (high position)	0.1Mwh	Read only		2326H

Input terminals ON/OFF status illustration

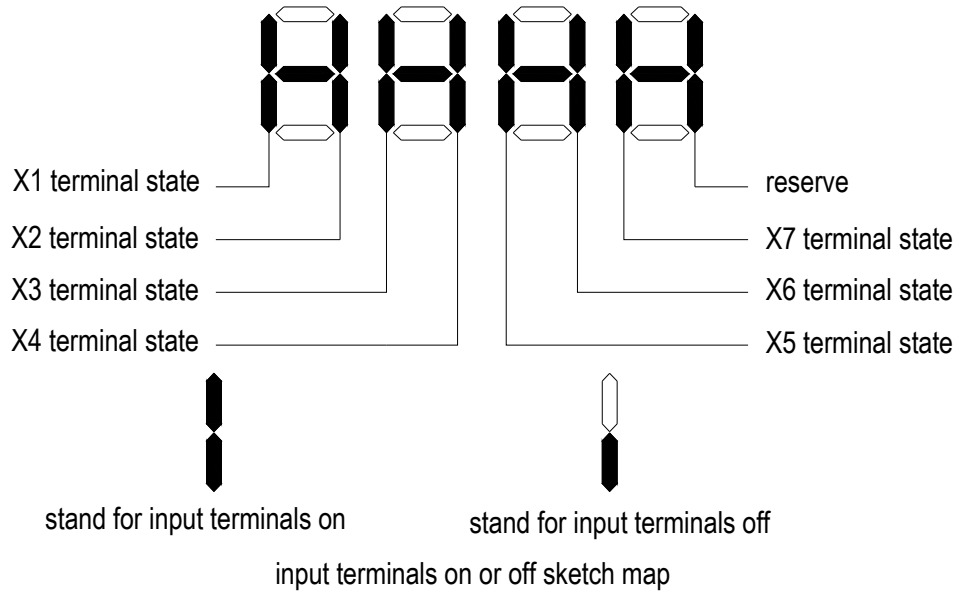

Chapter 6 Operation Guidance

6.1 Asynchronous Motor Pump Drive Operation Guidance

1) Wiring:

- a. Confirmed the solar pump drive if mating with motor.
- b. Correctly connecting “+”“-” of solar panel to corresponding “+”“-” pole of inverter or R, T wiring terminals. Otherwise it will cause inverter damage.
- c. Connect motor wire and ground wire to corresponding U, V, W, E terminals.

2). Parameters setting and trial run:

- a. Set F0.00 to 0, F0.02 for 0, and F0.09, F0.11, F0.14, F0.15 parameters setting according to application site.
- b. Set motor(pump) parameters according to nameplate of pump.
- c. Set solar pump MPPT mode F14.001 for 1 or 2.
- d. Press FWD button for trail running, and confirm the motor running direction.

3) Common problems

- a, Q : Well-lit conditions, the pump is running, but the water is very small.
A : Check if the pump motor direction is reversed.
- b, Q : Well-lit conditions, the drive is in standby mode 0.00Hz.
A : Check F14.01, observe what protection status is the drive in currently, check whether the parameters set is reasonable.
- c, Q : DC current is incorrectly displayed.
A : Adjust F14.30, F14.31 for calibration.
- d, Q : Well-lit conditions, frequency severe beating during operation.
A : Reasonably adjust F14.06 value, the adjustment is recommended to be in the vicinity of the default, too big or too small will cause frequency oscillation.

6.2 Synchronous Motor Pump Drive Operation Guidance

1) Wiring:

- a. Confirm if the solar pump drive matches with the motor.
- b. Connecting “+”“-” of solar panel to corresponding “+”“-” of inverter or R, T wiring terminals. Otherwise it will cause inverter damage.
- c. Connect motor wire and ground wire to corresponding U, V, W, E terminals.

2) Parameters setting and trial run:

- a) . Set F0.00 to 6, F0.02 for 0, and F0.09=100.00, F0.11=100.00; F0.14, F0.15 can be set according to demand.
- b). Set motor (pump) parameters according to nameplate of pump. Then Set F5.20 for 1, the keypad will show T-00, press FWD to start motor auto tuning. This process takes about three minutes;

Note: 1. If you can disconnect the motor and load, self-learning would be better;

2. The self-learning need to be done with enough sunshine and when the solar panels can provide enough

energy.

- c). Set solar pump MPPT mode F14.001 for 1 or 2.
- d). Press FWD button for trail running, and confirm the motor running direction.

3) Common problems and solutions

a, Q : Well-lit conditions, the pump is running, but the water is very small.

A : Check if the pump motor direction is reversed.

b, Q : Well-lit conditions, the drive is in standby mode 0.00Hz.

A : Check F14.01, observe what protection status is the drive in currently, check whether the parameters set is reasonable.

c, Q : DC current is incorrectly displayed.

A : Adjust F14.30, F14.31 for calibration.

d, Q : Well-lit conditions, frequency severe beating during operation.

A : Reasonably adjust F14.06 value, the adjustment is recommended to be in the vicinity of the default, too big or too small will cause frequency oscillation.

e, Q : The current fluctuation is huge when the pump is running.

A : Check C02.39, adjusting the value of F5.24, so the C02.39 displays the value from 0-10.

6.3 PV Water Pump Features

A. Sleep Function

During the photovoltaic pump operation, the inverter will go into sleep state when the DC voltage provided by solar panels is lower than FE.11 (sleep voltage threshold) due to objective factors, while the keyboard warning "A.LPn"; when DC voltage provided by solar panels rises back to F14.12 (sleep recovery voltage) point, start timing and after FE.13 (sleep shutdown waiting time), the drive starts running.

B. Low-frequency Protection Function

During the operation of the photovoltaic pump, for some reason, the output frequency is lower than F14.14 (low frequency detection frequency), and after F14.15 (under frequency detection time) time, enters into the standby protection state, while the keyboard warning "A.LFr"; after entering into the standby protection state and after F14.16 (frequency protection automatic recovery) time, automatically resume to running state.

C. Dry Run Protection

During the operation of the photovoltaic pump, for some reason, the output current is less than F14.17 (dry protection current detection), and after F14.18 (dry protection detection time) time, enters into standby protection state, while the keyboard warning "A.LuT"; after entering into the standby protection state and after F14.19 (dry protection automatic recovery)time, automatically resume to running state.

D. Over-current Protection

During the operation of the photovoltaic pump, for some reason, the output current is greater than F14.20(dry protection current detection), and after F14.21 (dry protection detection time) time, enters into standby protection state, while the keyboard warning " A.oLd "; after entering into the standby protection state and after F14.22 (dry protection automatic

recovery)time, automatically resume to running state.

E. Minimum Power Protection

During the operation of the photovoltaic pump, for some reason, the output power is less than F14.23(minimum power protection value), and after F14.24 (minimum power protection detection time) time, enters into standby protection state, while the keyboard warning "A.LPr"; after entering into the standby protection state and after F14.25 (minimum power automatic recovery)time, automatically resume to running state.

F. Full Water Protection

Detect the water full alarm and low water level through two X terminals, realizing automatic level control. Wherein F14.27 is the water overflow protection detection time and F14.28 is full water protection exit time, and X 3 terminal is defined as full solar water detection alarm, and X4 terminal is defined as full solar water detection alarm reset, the warning signal is shown as "A.Ful".

G. Alarm Recovery Mode: 0: automatic recovery; 1: manual recovery

This option is for low frequency protection, dry protection, over-current protection, minimum power function; you can select the alarm restoration by F14.26. When you select 0 for automatic recovery, during fault warning displaying, you can also press the "RESET" button to stop operation; during fault warning displaying, you can press the "RESET" button to manually clear, you can also press "RESET" button to achieve stop operation.

H. PQ Curve Function

This model provides a self-defined PQ curve for users to set up five groups of PQ corresponding points according to the pump cases, to achieve real-time traffic speed, daily flow, cumulative flow, generating capacity, cumulative electricity consumption; of which by default, daily flow and generating capacity are calculated based on 7h in a day.

I. Status Check

When the photovoltaic pump is running, you can check F14.01 to confirm the current operating status.